

Thermal Stress and Reliability for Advanced Power Electronics and Electric Machines



*U.S. Department of Energy
Annual Merit Review*

Michael P. O'Keefe
National Renewable Energy Laboratory

Friday May 22, 2009

Presented at the 2009 U.S.DOE Hydrogen
Program and Vehicle Technologies Program
Annual Merit Review & Peer Evaluation Meeting
held 18-22 May 2009 in Arlington, Virginia

NREL/PR-540-45772 **APE-14**

This presentation does not contain any proprietary, confidential, or otherwise restricted information

Overview

Timeline

- Project start date: FY08
- Project end date: FY11
- Percent complete: 40%

Budget

- Total project funding
 - DOE share: \$655k
 - Contractor share: \$0.00
- FY08 Funding: \$280k
- FY09 Funding: \$375k

Barriers

- 15 year life requirement
- The time & cost required to validate the reliability of new technology can **delay** and **even prevent its introduction**

Partners

- Interactions
 - FreedomCAR Electrical & Electronics Technical Team
 - Dr. E. Suhir of UC Santa Cruz, Oak Ridge National Laboratory, AES, J. Didion of NASA, Others
- Project lead: NREL

Thermal Stress/Reliability Project Objectives

- Develop validated models and tools to **assess** the ability of power module concepts to meet the 15 year program life requirement
- Investigate how **variation** and **uncertainty** affect reliability of APEEM R&D concepts
- **Apply** the tools & techniques of **robust design** to APEEM R&D early in the design stage to increase technology robustness and chance of adoption

Project Milestones

FY2008

- **Milestone:** Develop research plan for conducting thermal stress and reliability assessment

FY2009

- **Milestone:** Report on status and results of the thermal control technology R&D

Technical Approach

- Compare reliability of 3 APEEM packages
 - Boundary conditions, properties obtained, geometry based on existing systems
 - Focus on die attach and DBC attach
- Examine the effect of variability on results
- Obtain validation data via APEEM industry contracts and DOE testing activities
- Review results with FreedomCAR EETT
- Redesign APEEM technology for reliability
- Transition models and methods to industry

Will These Cooling Concepts Last the Life?

Failure sites of concern:

1. Wire bonds
2. Bonded joints (die attach & DBC attach)

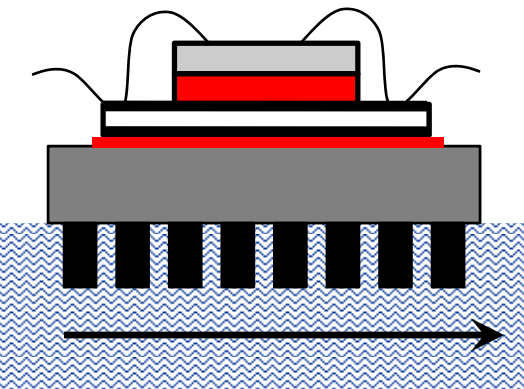

**Baseline Pin-fin
Heat Exchanger**

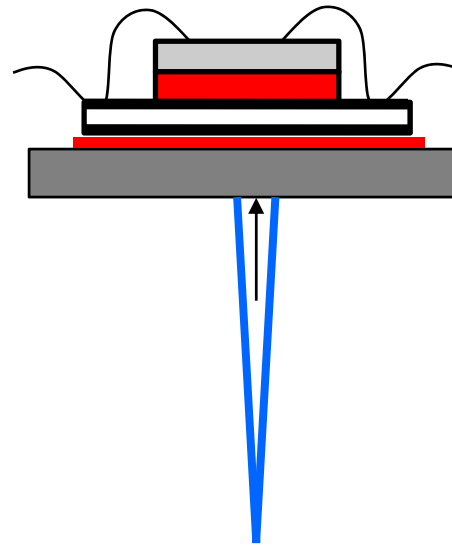

**Indirect Jet Impingement
on Baseplate**

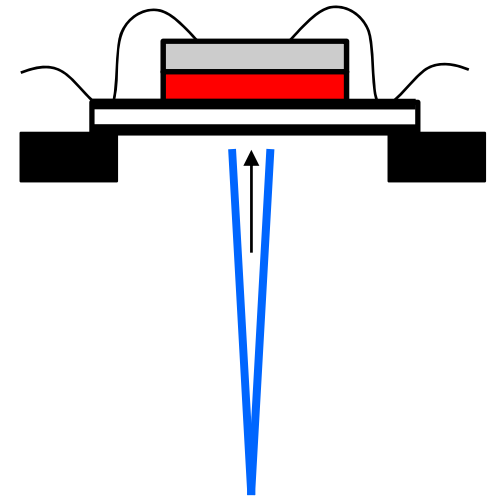

**Indirect Jet Impingement
on DBC**

decreasing thermal resistance (increased stress?)

Simulation Process for Reliability Assessment

Input Parameters

Geometry

dimensions,
topology, etc.

Materials

kinds of materials,
properties

Loading

heat input, test
procedure

CAD Model

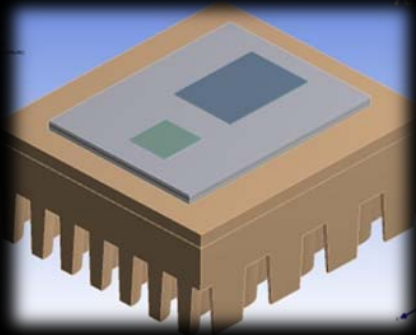

Thermal Simulation

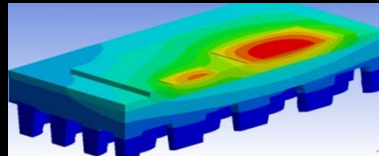

Cycle Counting

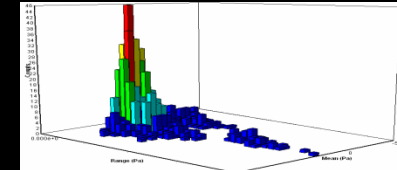

Structural Simulation

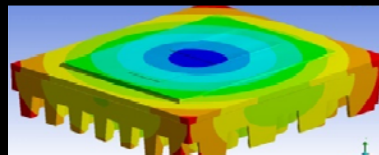

Fatigue Analysis

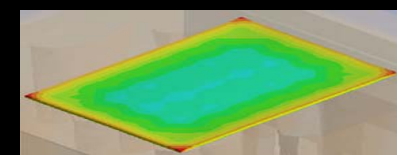

Output Parameters

Thermal

max temperature,
temperature range

Mechanical

max and min
stress, strain

Life

fatigue life of
component x

Applying techniques from physics of failure,
design for six sigma, optimization, and
advanced modeling to R&D

Validation of Jet Boundary Conditions

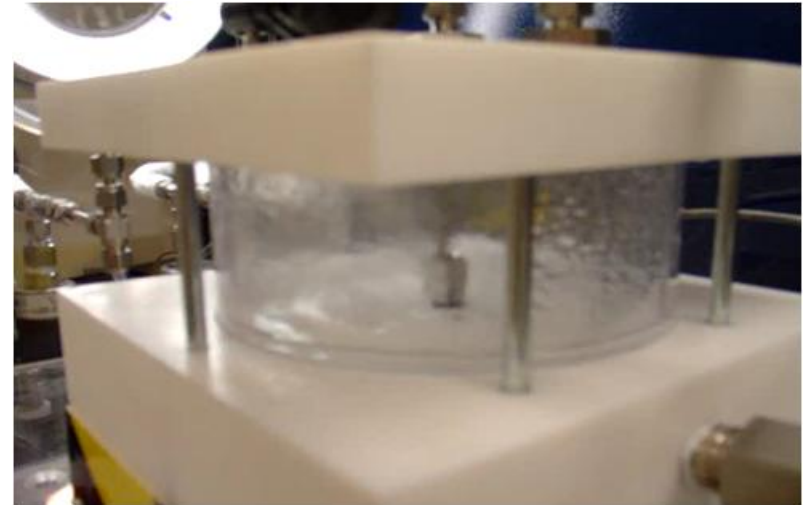
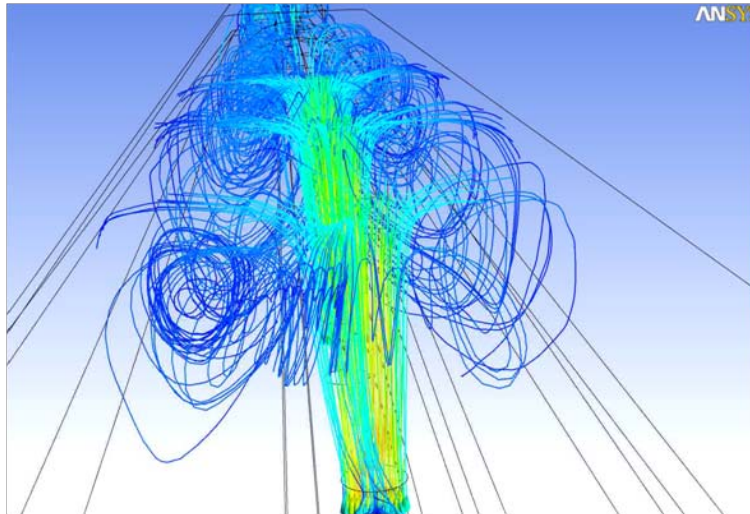

Parameter	Value via CFD	Value via Test
heat transfer coefficient (W/m ² .K)	18,350	18,481

Jet Boundary Condition Varies over Surface

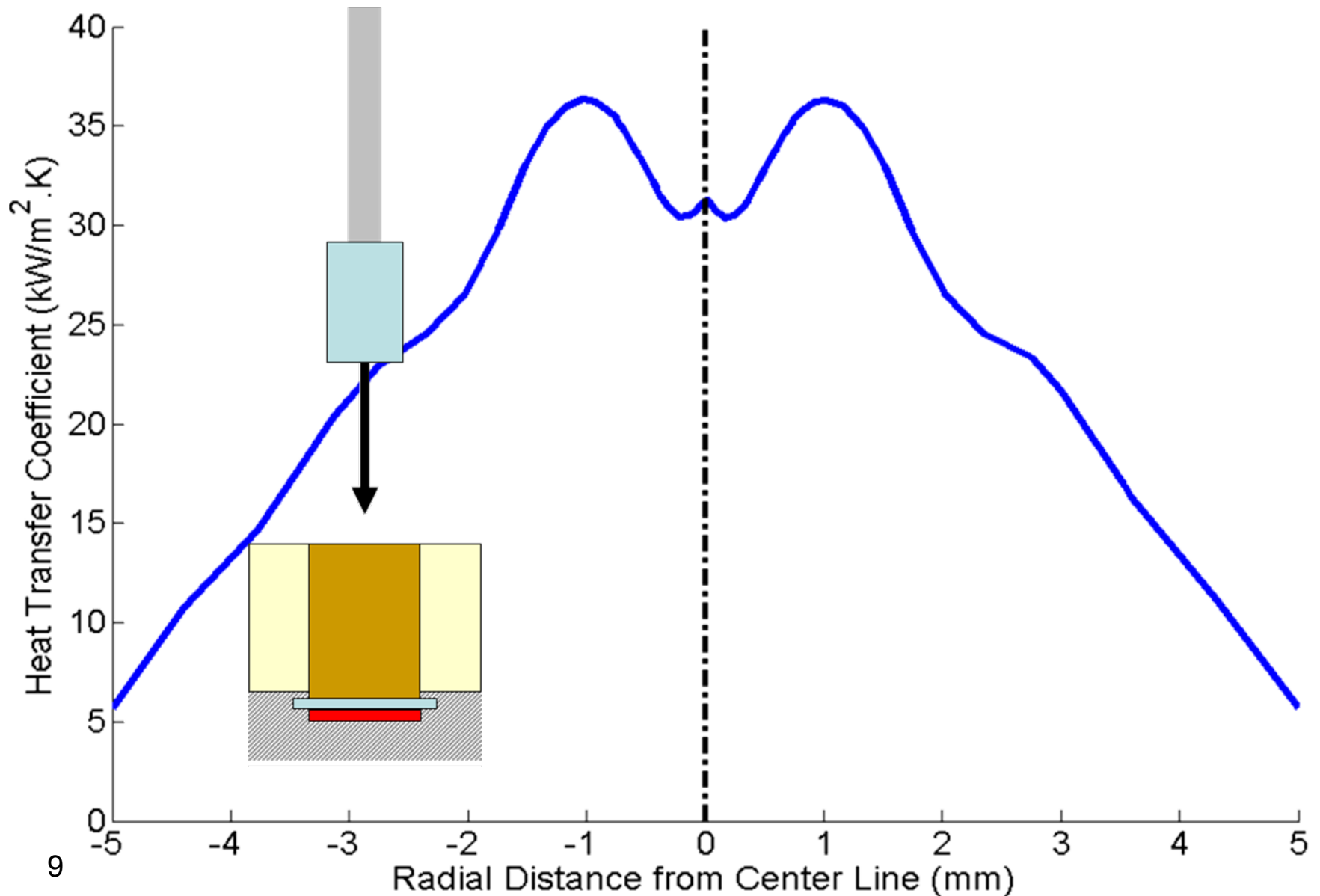

Validation of Pin-Fin Boundary Conditions

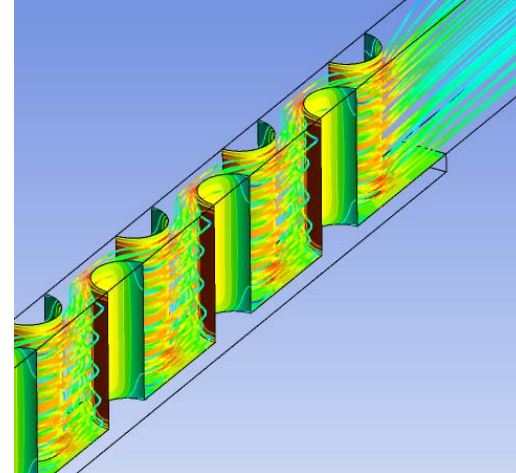
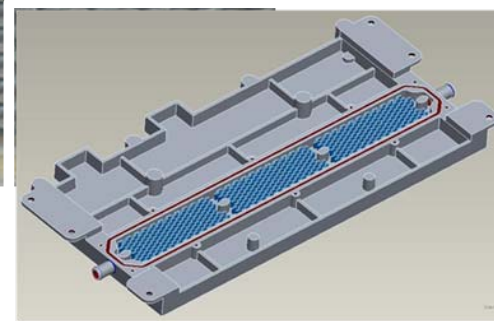
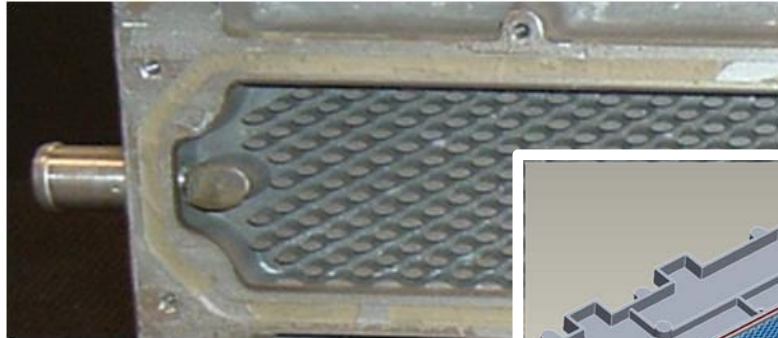

Pin Type	Parameter	Value via Empirical Correlation	Value via CFD Analysis
Circular	heat transfer coefficient (W/m ² .K)	9501	9941

Solid Models of Three Topologies Created

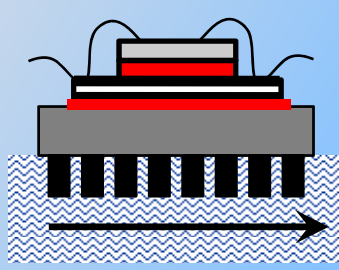
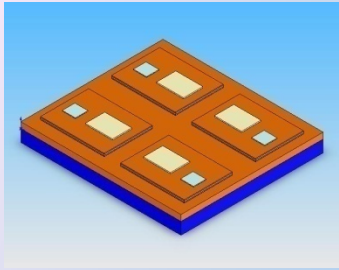

Topology 1

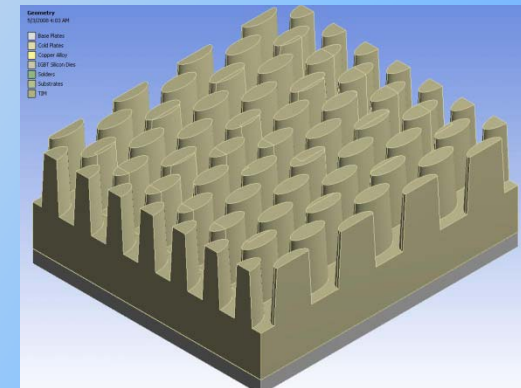
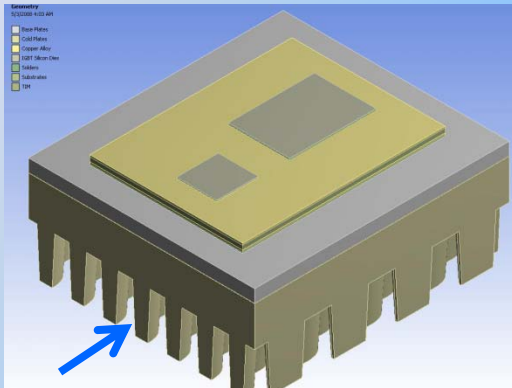

Baseline Pin-Fin

Topology 2

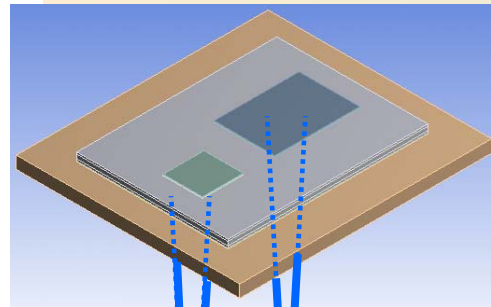

Two jets (one per chip)
Jet Velocity: 4.5 m/s
Nozzle diameter: 1.4 mm

Jets on Baseplate

Topology 3

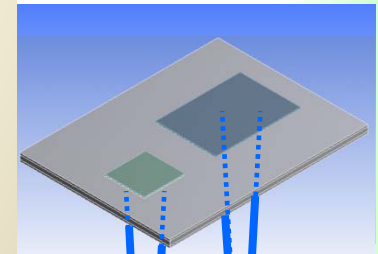

Jets on DBC

Effect of Heat Transfer Coefficient on Maximum IGBT Temperatures for all Topologies

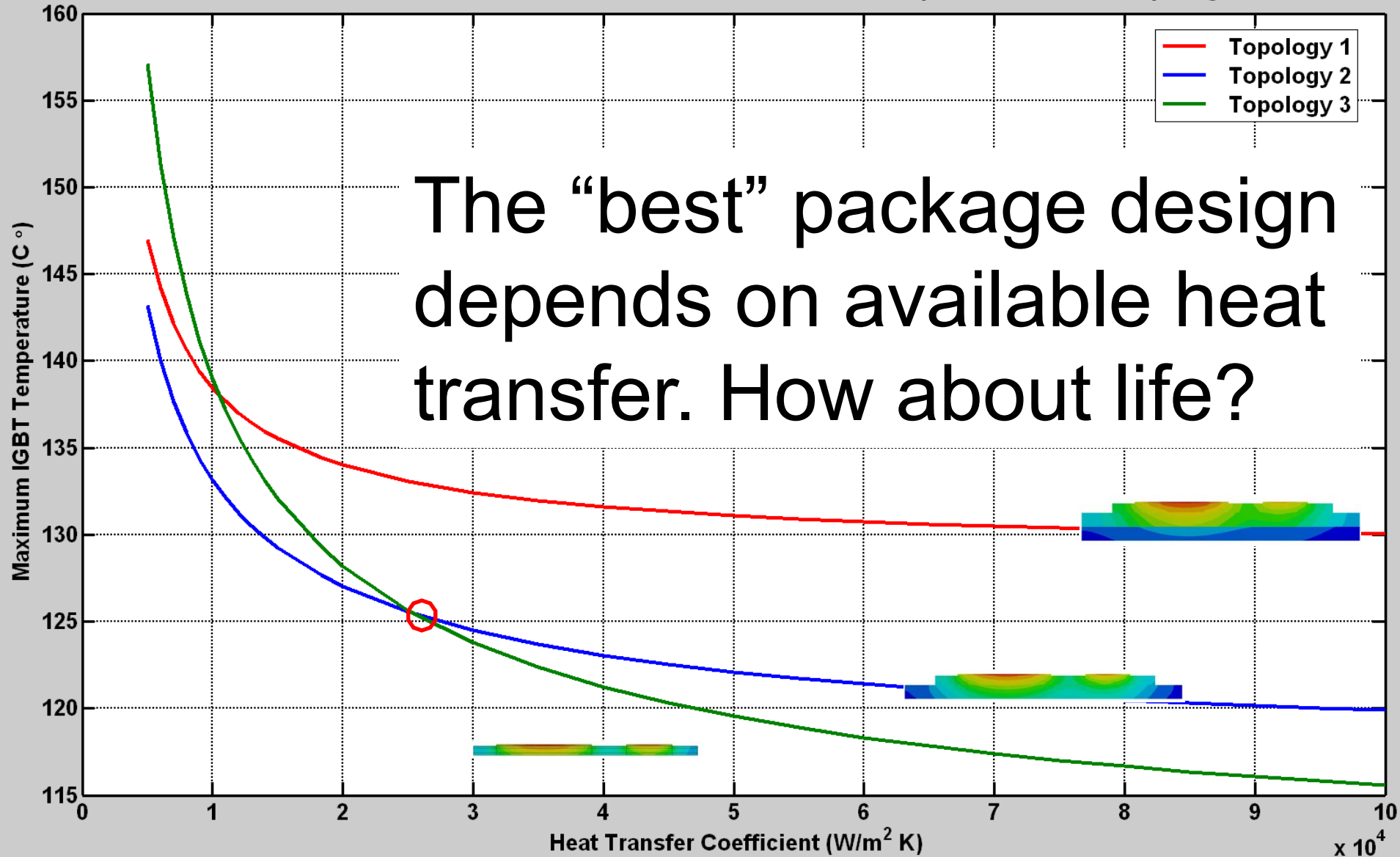

The “best” package design depends on available heat transfer. How about life?



pin-fin performance

jet performance

Analytical Models Add Confidence to FEA Results

Parameter	FEA	Analytical (bi-metal thermostat)
Axial Stress in IGBT (MPa)	87.7	79.2
Axial Stress in DBC (MPa)	130.4	137.8

analytical model based on:

Suhir, E. (1986). "Stresses in Bi-Metal Thermostats". *Journal of Applied Mechanics*.

Analytical Stress Add Confidence to FEA Results

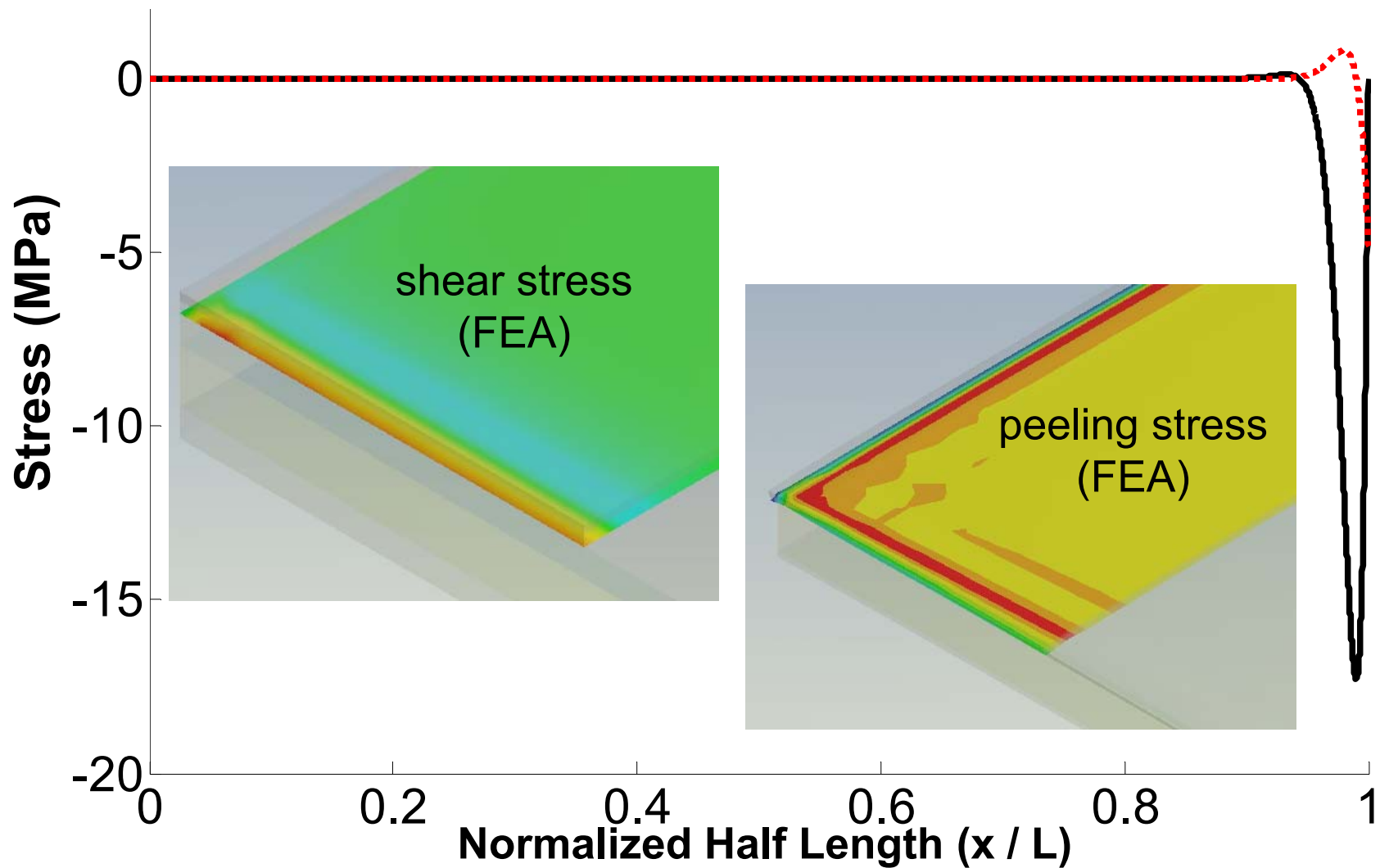

source: Ru, C.Q. (2002). "Interfacial Thermal Stresses in Bimaterial Elastic Beams: Modified Beam Models revisited".
Journal of Electronic Packaging.

Connecting Reliability to Mission Profile

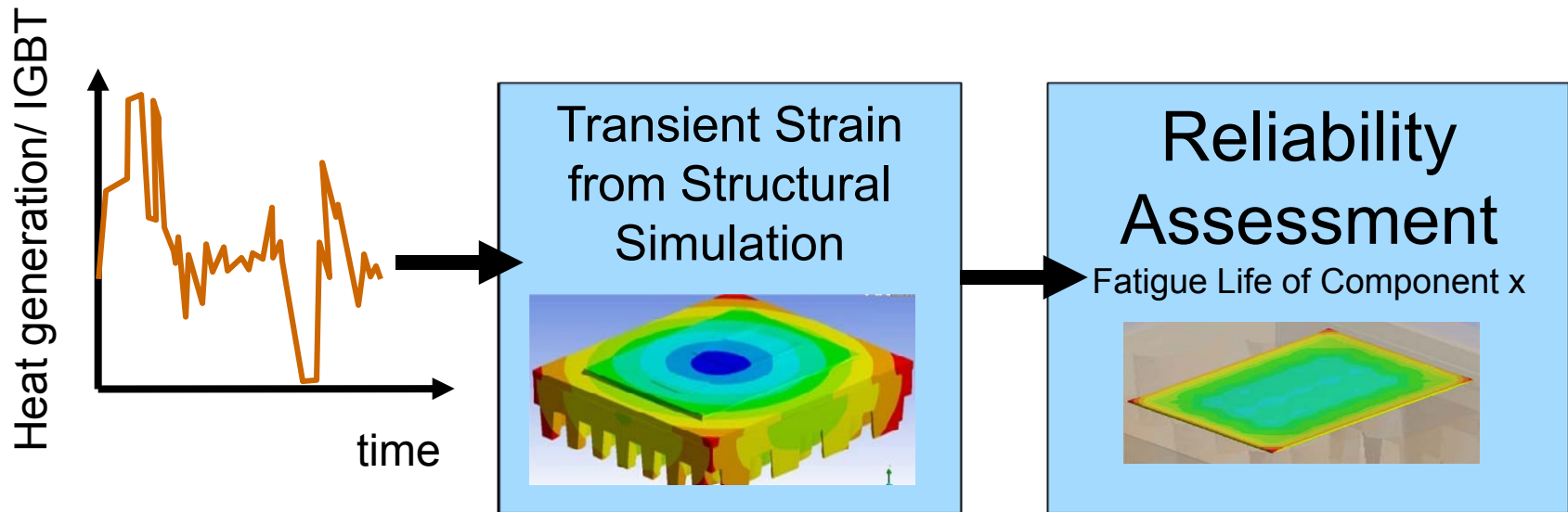
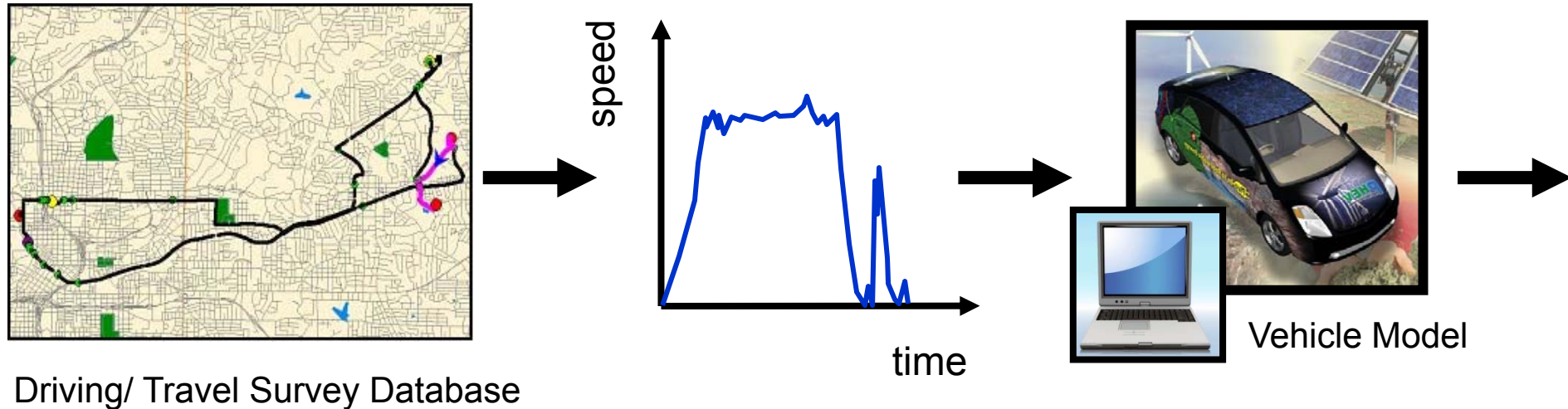

Power Cycling Test to Generate Fatigue Damage

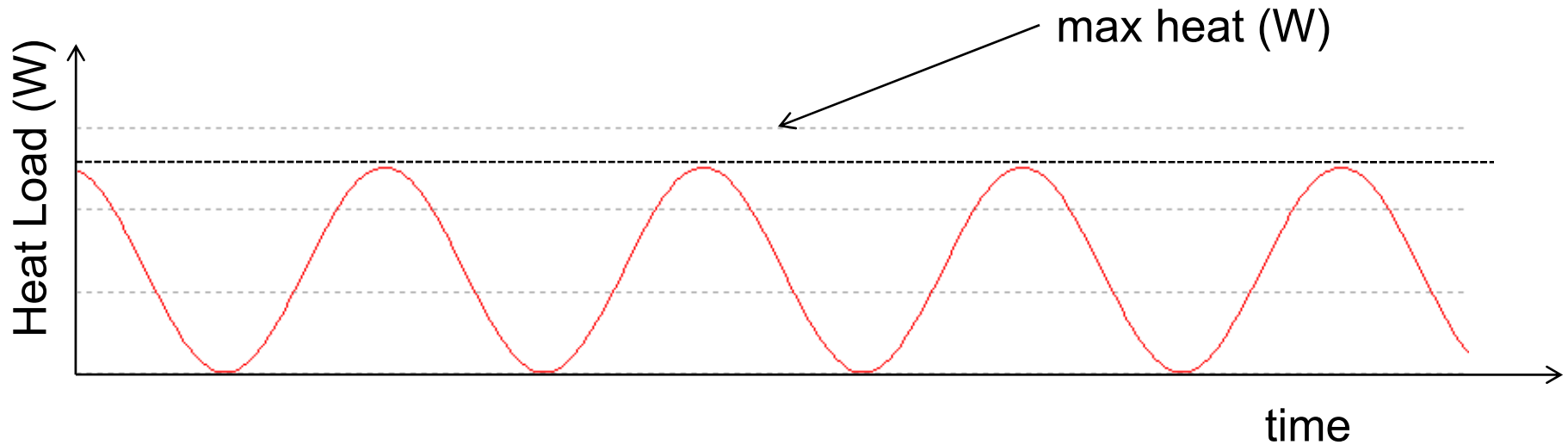

- The IGBT & diode heat generation has constant amplitude and cycles between 0 and maximum
- The max temperature appears at the IGBT
- Thermal and stress/strain gradients are maximized between adjacent layers

Thermal Fatigue Simulation

1. Uses empirical models that predict fatigue life of solder joints from elastic/plastic strains and temperatures
2. The Manson-Coffin relation is used within the FEA simulation to account for elastic and plastic strain damage
3. Fatigue constants for strain-life approach are determined from the literature and fitting of experimental data

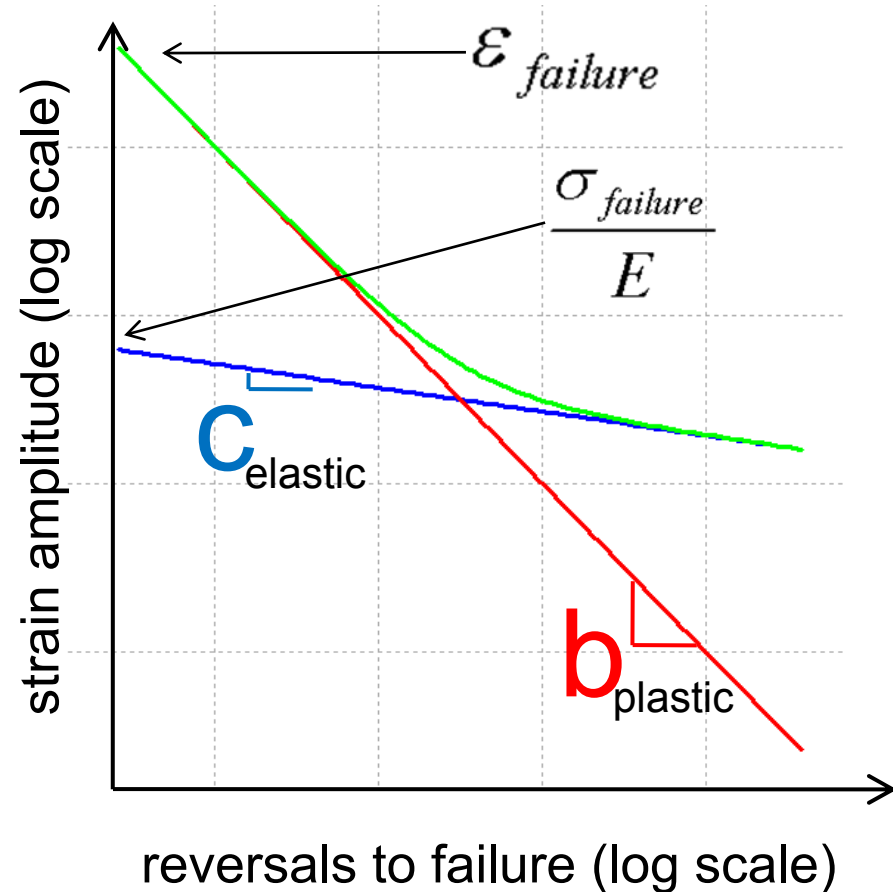

$$\frac{\Delta \varepsilon}{2} = \frac{\sigma_{failure}}{E} \cdot \left[2 \cdot N_{failure} \right]^b + \varepsilon_{failure} \cdot \left[2 \cdot N_{failure} \right]^c$$

Future Work: FY2009 & FY2010

- Validate model prediction against test
- Investigate the effect of uncertainty & variation on reliability predictions
- Design APEEM R&D for reliability
- Review results and methods with industry
- Milestone in May: Report on FY09 modeling activity to date

Summary

DOE
Mission
Support

- Overcome barriers to adoption of low-cost petroleum saving PEEM technology by using CAE tools to design-for-reliability including the effects of variability on our R&D
 - guide R&D decisions, reduce deployment time, identify barriers to meeting life/reliability goals, increase R&D robustness

Approach

- Create and validate parametric solid models of technologies of interest to the DOE program (advanced cooling strategies chosen this year). Use standard design practices to enhance robustness of the concepts.

Summary

Technical Accomplishments

- Created parametric solid models of 3 packages
 - thermal boundary conditions analyzed & created
 - material properties identified
 - bonded joint fatigue (soldered & sintered interface)
 - in-process of validating model versus test data
 - relative comparison of life implications of packages

Collaborations

- Collaborating for expertise and validation
 - interacting with Auto OEMs and suppliers for test data, review, and validation activities
 - interacting with other national laboratories (ORNL), other government institutions, and academic institutions on reliability, modeling, and technology

Publications and Presentations

FY08

- DOE Milestone: “Thermal Stress and Reliability for Advanced Power Electronics: Current Status and Future R&D Activities.” July, 2008.
- DOE FY2008 Annual Progress Report on Advanced Power Electronics and Electric Machinery, “Thermal Stress & Reliability for Advanced Power Electronics & Electric Machines”.

FY09 (Planned)

- DOE Milestone: “Report on Reliability Modeling for Advanced Power Electronics.” June, 2009.
- DOE Milestone: “Report on Status and Results of Thermal Stress & Reliability R&D.” September, 2009.
- Conference Papers:
 - “Reliability Impacts of Cooling Strategies for Power Modules in Electric Traction Drive Vehicles.” 5th IEEE Vehicle Power and Propulsion Conference, 2009. (Paper in Progress).
 - “Sensitivity of Bonded Joint Fatigue to Sources of Variation in Advanced Vehicular Power Electronics Cooling.” ASME International Mechanical Engineering Congress, November 2009. (Paper in Progress).

Critical Assumptions and Issues

Value Added to the Program

- The application of computer aided engineering (CAE) tools to design reliability into a concept is a critical aspect of deploying novel laboratory technology into the marketplace.

Model Validation

- Models must be validated to “earn our way out of testing”.
- This activity should be coordinated with other DOE power electronics testing activities to best leverage the funding on expensive testing activities.
 - This activity can add value to testing by anticipating test results and thus help to set up an optimal test, allow for the investigation of phenomena that cannot be directly measured during testing, and assist with the interpretation of test results.
- It will be important to define “standards” for reliability testing and simulation within the DOE program such that results from one investigation can be compared against work from others.