

SERI/TP-257-3737
UC Category: 261
DE90000330

A Low-Cost PC-Based Telemetry Data-Reduction System

**D. A. Simms
C. P. Butterfield**

April 1990

Prepared for the
Fourth National Conference on
Microcomputer Applications in Energy
Tuscon, Arizona
25 April 1990

Prepared under Task No. WE011001

Solar Energy Research Institute

A Division of Midwest Research Institute

1617 Cole Boulevard
Golden, Colorado 80401-3393

Prepared for the
U.S. Department of Energy
Contract No. DE-AC02-83CH10093

NOTICE

This report was prepared as an account of work sponsored by an agency of the United States government. Neither the United States government nor any agency thereof, nor any of their employees, makes any warranty, express or implied, or assumes any legal liability or responsibility for the accuracy, completeness, or usefulness of any information, apparatus, product, or process disclosed, or represents that its use would not infringe privately owned rights. Reference herein to any specific commercial product, process, or service by trade name, trademark, manufacturer, or otherwise does not necessarily constitute or imply its endorsement, recommendation, or favoring by the United States government or any agency thereof. The views and opinions of authors expressed herein do not necessarily state or reflect those of the United States government or any agency thereof.

Printed in the United States of America
Available from:
National Technical Information Service
U.S. Department of Commerce
5285 Port Royal Road
Springfield, VA 22161

Price: Microfiche A01
Printed Copy A02

Codes are used for pricing all publications. The code is determined by the number of pages in the publication. Information pertaining to the pricing codes can be found in the current issue of the following publications which are generally available in most libraries: *Energy Research Abstracts (ERA)*; *Government Reports Announcements and Index (GRA and I)*; *Scientific and Technical Abstract Reports (STAR)*; and publication NTIS-PR-360 available from NTIS at the above address.

A Low-Cost PC-Based Telemetry Data-Reduction System

D. A. Simms
C. P. Butterfield

Solar Energy Research Institute
1617 Cole Boulevard
Golden, Colorado 80401

ABSTRACT

The Solar Energy Research Institute's (SERI) Wind Research Branch is using Pulse Code Modulation (PCM) telemetry data-acquisition systems to study horizontal-axis wind turbines. PCM telemetry systems are used in test installations that require accurate multiple-channel measurements taken from a variety of different locations. SERI has found them ideal for use in tests requiring concurrent acquisition of data from multiple wind turbines and meteorological towers in wind parks. SERI has developed a low-cost PC-based PCM telemetry data-reduction system to facilitate quick, in-the-field multiple-channel data analysis. Called the "PC-PCM System," it consists of two basic components. First, AT-compatible hardware boards are used for decoding and combining PCM data streams. Up to four hardware boards can be installed in a single PC, which provides the capability to combine data from four PCM streams directly to PC disk or memory. Each stream can have up to 62 data channels. Second, a software package written for the DOS operating system was developed to simplify data-acquisition control and management. The software provides a quick, easy-to-use interface between the PC and PCM data streams. Called the "Quick-Look Data Management Program," it is a comprehensive menu-driven package used to organize, acquire, process, and display information from incoming PCM data streams. This paper describes both hardware and software aspects of the SERI PC-PCM system, concentrating on features that make it useful in an experiment test environment to quickly examine and verify incoming data. Also discussed are problems and techniques associated with PC-based telemetry data acquisition, processing, and real-time display.

INTRODUCTION

PCM telemetry systems were originally developed and used by the military and by aerospace industries. Although the technology is well established and has been rigorously tested, military grade systems are typically too expensive for common applications. Recently, less expensive systems designed for practical commercial use have become available.

PCM-encoded telemetry data systems provide highly accurate measurements over a wide dynamic range with low noise (Strock 1983). These systems are ideal for collecting data related to the study of wind turbines, especially in multiple-turbine wind parks. Typical test installations require multiple-channel measurements taken from a variety of different locations. These can be grouped into three basic categories: turbine rotating, turbine nonrotating, and meteorological.

In the rotating-turbine frame, measurements are made on the turbine blades, blade attachments, and hub. Typical parameters include strain-gauge bending moments and torsion, airfoil surface pressure distributions, total dynamic pressure, and blade pitch angle. These measurements provide data to determine blade aerodynamic and structural loads.

In the nonrotating-turbine frame, measurements characterize machine performance and determine turbine loads. This requires data from the turbine nacelle and tower, such as generator power production, tower bending, azimuth and yaw angles, and rotation speed.

To determine characteristics of the wind at a turbine or wind park, meteorological conditions are measured. Anemometers are used to measure near-field horizontal and vertical wind shear. This requires many channels of data on wind speed and wind direction from local upwind anemometer arrays. Atmospheric stability measurements are also important in evaluating characteristics of wind park inflow and outflow. This requires far-field atmospheric boundary layer measurements, including anemometer, temperature, barometric pressure, and dewpoint.

To increase accuracy, simplify installation, and reduce noise, many channels of analog signals are digitized, multiplexed, and encoded into a single PCM stream as close to the

measurement source as possible. The stream is then telemetered to a convenient central receiving location and combined with streams from other sources to form a complete digital data set. Streams originating from remote or difficult-to-reach locations can be easily transmitted over a radio-frequency (RF) link. RF links have been especially useful in simplifying data acquisition from sensors located on rotating wind turbine blades.

Figure 1 depicts the current "Combined Experiment" (Butterfield 1989) under way at SERI, sponsored by the U.S. Department of Energy (DOE), to provide detailed measurements on a 10-meter, 3-bladed horizontal-axis wind turbine. The objective of the experiment is to develop an understanding of how turbulent inflow affects unsteady aerodynamics, fatigue loads, and yawed operation loads. The experiment uses seven PCM streams for data collection. Three streams are from the rotating frame, two from local inflow, one from the turbine/tower, and one from far-field meteorology. Characteristics of the streams are summarized in Table I. The streams are recorded on wide-band tape and are monitored in the field using the Quick-Look system and a special PCM test instrument called a D/PAD (Loral Instrumentation 1987).

Table I. Combined Experiment PCM Configurations

PCM #	Bit Rate (Kbit/s)	Sample Rate (Hz)	Number of Channels	Sample Interval (msec)	PCM Source Location
1	7.5	34.72	16	28.8	Far met
2	15	69.44	16	14.4	Inflow
3	60	277.78	16	3.6	Local met
4	400	520.83	62	1.92	Rotor
5	400	520.83	62	1.92	Rotor
6	400	520.83	62	1.92	Rotor
7	60	277.78	16	3.6	Turbine

PCM data streams recorded on tape are postprocessed on an extensive laboratory-based telemetry data-reduction system (Fairchild Weston 1985). Figure 2 shows the complete data processing path used to reduce the PCM data. This system processes all recorded data, providing them in digital format for use in subsequent data analysis on a UNIX-based computing system.

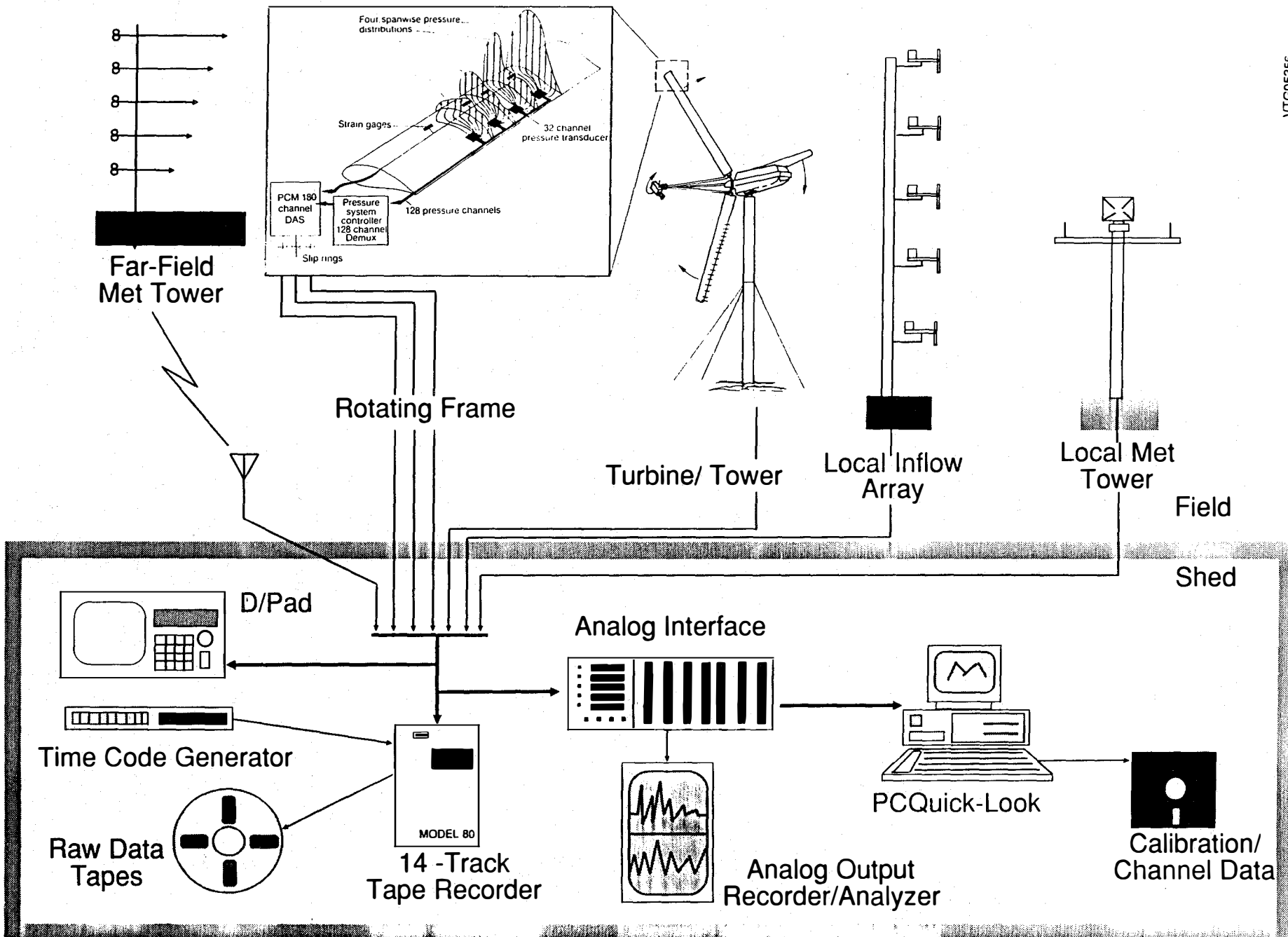

VTG05356

Figure 1. Combined Experiment PCM Streams

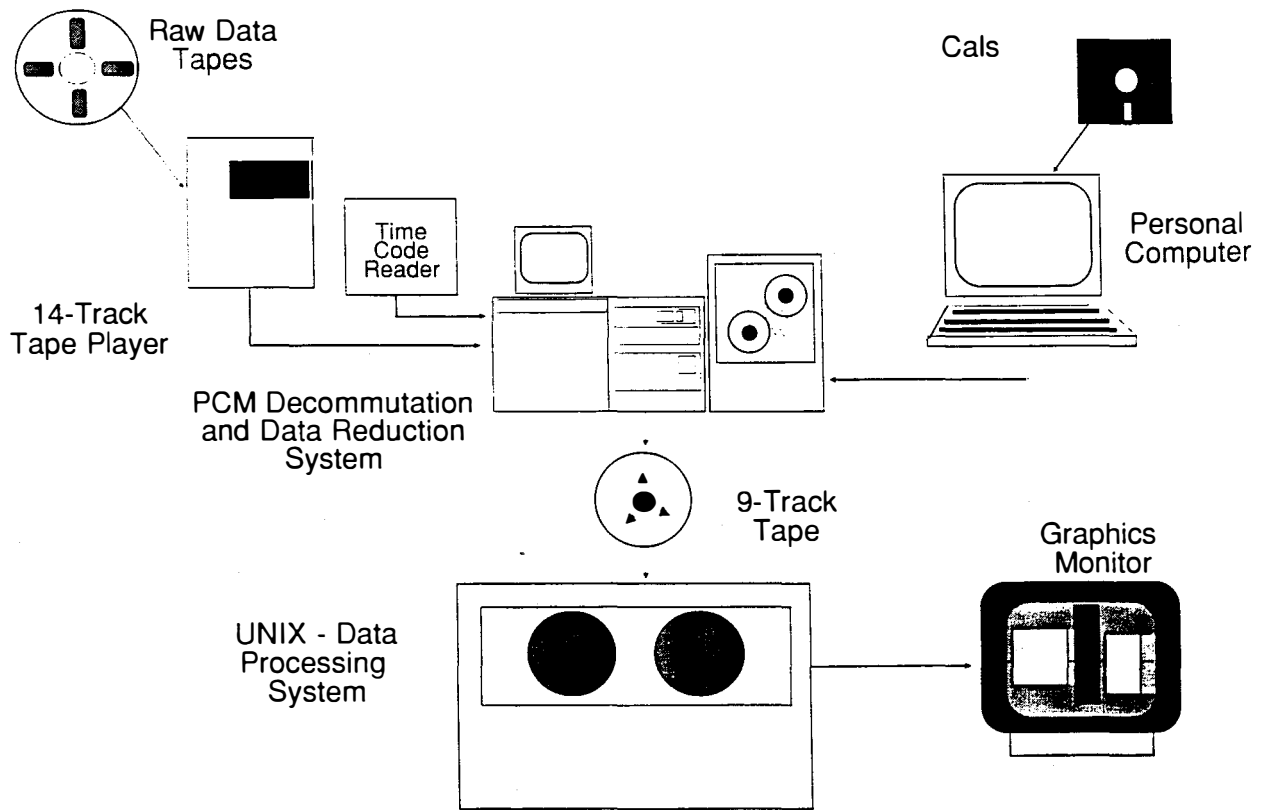

Figure 2. Full PCM data reduction and processing

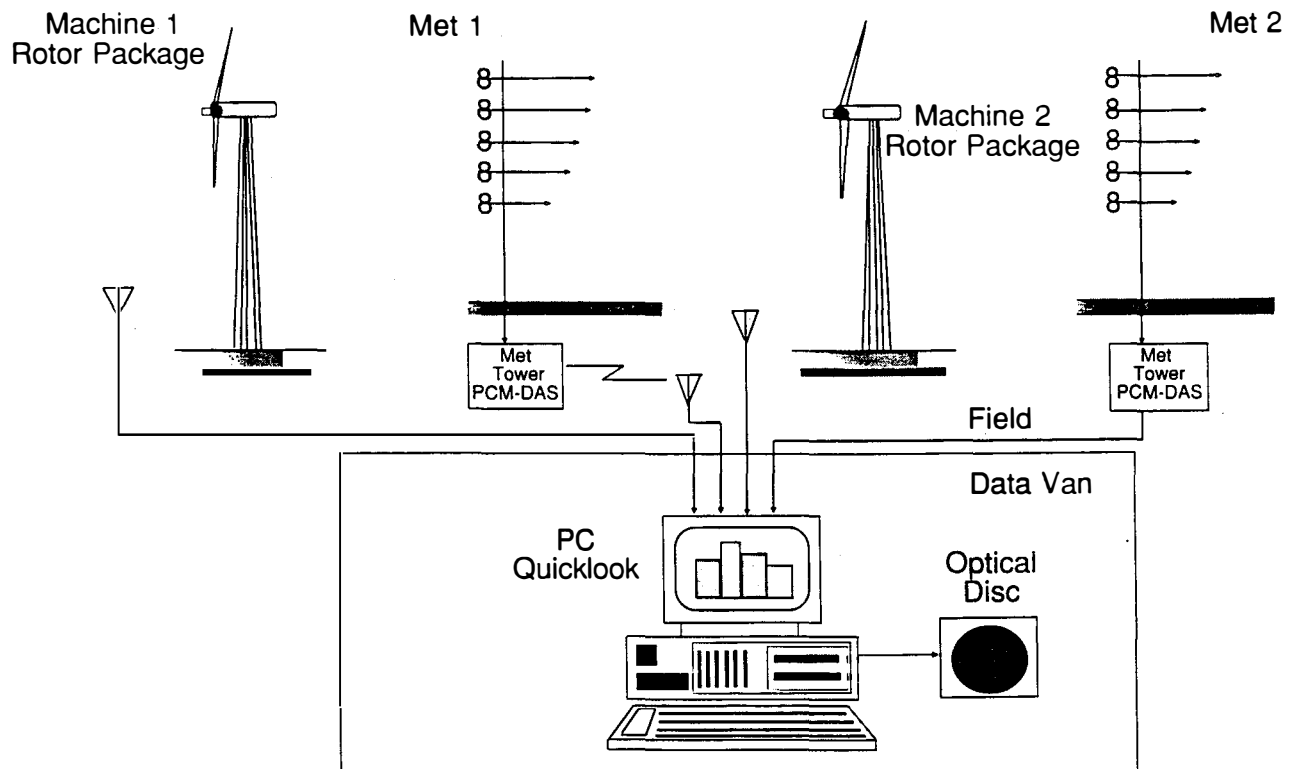

Figure 3. Wind farm multiple-machine/met tower PCM scenario

SERI's wind program is also conducting various other field tests in an effort to assist wind industries in the United States to improve reliability and performance of wind turbines. Some current studies include wind park inflow-outflow characterization and advanced airfoil testing. These tests are not as comprehensive as the Combined Experiment described above. Typically of short duration, they are designed with one or two specific objectives in mind. Data collection needs are on the order of 50 channels with 10-Hz maximum bandwidth. A typical test layout is shown in Figure 3. Multichannel hub-mounted rotor packages (McKenna 1990) facilitate rotating-frame measurements from multiple turbines.

SERI has been using PCM systems for many years, bearing their high cost to ensure quality data measurements. Given conditioned analog signals, it is relatively inexpensive to encode and multiplex multichannel data into a PCM stream. The expense lies in providing adequate PCM data decoding and reduction.

In the past, we had two ways to decode PCM data streams. One involved using a simple PCM-decoding test instrument in the field. The other was to use our full laboratory-based decoding and data-reduction system shown in Figure 2. These two systems represent the extremes of PCM data decoding capability. Neither adequately satisfied our field data processing requirements. What we really needed was a system that combined features of both to provide test engineers in the field with data processing, analysis, and display capabilities.

Specifically, we required multiple-stream decoding, derivation of parameters from all channels (across PCM streams), graphic display, data storage, and a means to rapidly update many channels of calibration coefficients. We also needed the ability to monitor long-term meteorological conditions for evaluating test status. These field capabilities are essential because debugging using laboratory-based postprocessing is inefficient and impractical. We could not find a commercial system with these features that could be inexpensively duplicated at our many test sites. We therefore decided to develop our own PC-based PCM system to provide the required field test capabilities. The system consists of PCM-decoding hardware boards (Simms and Butterfield 1990) and a custom Quick-Look PCM data management software program (Simms 1990).

INTERFACING A PC TO PCM DATA STREAMS

The main function of the PC-PCM system is to interface a PC with PCM data. This requires some type of PCM-decoding hardware that can transfer data into a PC. Over the past few years in conjunction with a subcontractor, SERI has developed the PC-based PCM-decoding hardware system. This system consists of basic control software and printed circuit boards (APEX Systems Inc. 1988) that fit directly inside the chassis of a PC/AT or compatible computer. PCM data are decoded on the board and transferred to PC memory or disk. One board can decode one PCM stream at a time. Up to four boards can be installed into a PC, permitting data from four streams to be simultaneously combined. The PC-PCM decoder board specifications are summarized in Table II.

In conjunction with the PCM decoder boards, we also developed an analog interface module which reconstructs analog output from up to eight channels per stream. The basic intent was to enable test engineers to use real-time analog test instruments such as a spectrum analyzer or chart recorder. The analog module is an optional part of the system. Specifications are shown in Table III.

A full complement of four boards in a PC allows the Quick-Look program to manage data from up to 16 PCM streams. Each board has four inputs and can be quickly reconfigured to cycle through the inputs to grab-sample data from different PCM streams. Various combinations of cyclic or concurrent acquisition can be used. Maximum data-collection rates vary

depending on hardware limitations and other variables which are discussed in following sections.

Table II. Specifications for PCM Decoder Board

Bit rate.....	1-800 Kbits/sec
Input streams.....	4 (only one processed at a time)
Input polarity.....	Negative or positive
Input resistance.....	> 10 K ohms
Codes.....	Bi-phase L, NRZ
Bit sync type.....	Phase locked loop (PLL)
Input data format.....	8-12 bits/word, MSB first
Words per frame.....	2-64 (including sync)
Sync words per frame..	1-3 (maximum 32 bits)

Table III. Specifications for Analog Interface Module

Analog outputs.....	8 channels (user selectable via thumbwheels)
Output polarity.....	Unipolar or bipolar
Output range.....	0 to 10V, 0 to 20V, -5 to 5V, -10 to 10V
PCM inputs.....	4 (only one processed at a time)
Status lights.....	PLL lock, frame sync, FIFO, disabled

The PC-PCM boards support standard-format Inter-Range Instrumentation Group (IRIG)-compatible PCM streams with bit rates in the range of 1000 to 800,000 bits/sec, and a maximum of 64 data words (including sync) per frame. Assuming 12-bit data resolution, channel sample rates from 1.3 to 33,000 Hz are possible. Decoding subcommutated or supermultiplexed PCM data is not supported.

During acquisition of PCM data, all values are digital raw "counts" derived from binary data words that have been decoded from the PCM data streams. Data resolution is determined by the number of bits used to represent each measured data value. We typically use 12-bit resolution, which is 1 part in 2^{12} , corresponding to count values ranging from 0 to 4095. The Quick-Look program interprets the raw count values provided by the PCM decoding hardware and converts them to engineering units using calibration coefficients from its data base.

OVERVIEW OF THE QUICK-LOOK PROGRAM

The Quick-Look program is a comprehensive software package designed to manage data from multiple incoming data sources. The major objective in developing the program was to provide a way to quickly examine data from PCM streams in an experiment test environment. Other objectives include on-line channel data base management, hardware debugging capability, and automated calibration procedures.

Menus are presented to the user enabling quick selection of desired options. Each menu contains a title, followed by lines listing current available options. The user moves a highlighted bar to select the desired operation. At that point, another level of menu options may appear or option execution may begin.

The main program menu presents the user with options that are summarized in Table IV. These options identify all the basic features of the Quick-Look program.

Typical components of PC-based data-acquisition systems common to both the Quick-Look system and most commercial data-acquisition systems are not described here. This report concentrates on the particular capabilities of the Quick-Look program related to quick handling of PCM data in the field and conducting calibrations. Although this program was developed to allow the PC to be interfaced with PCM data, the capabilities for data management outlined here could be applied to other types of telemetry-based data handling systems as well.

Table IV. Quick-Look Program Features

Hardware Set-Up Define all parameters related to interfacing the PC with peripheral PCM decoding devices.
PCM Configuration Data Base Define and maintain the characteristics of all potential incoming PCM streams.
Channel Data Base Define and maintain information associated with all measured data channels.
Derived-Parameter Data Base Establish and organize ancillary derived channel equations.
Acquire Data Select channels, monitor current conditions, collect data and store them in a disk file.
Display Recorded Data Comprehensive graphic or alphanumeric display of previously recorded data sets.
Channel Calibration Generate calibration coefficients using a multiple-channel least-squares linear regression data processor.
File Maintenance Organize and catalog experiment-associated data files and channel data bases.
Test Event Log Record the sequence of experiment events.

LIMITATIONS OF PC-BASED DATA PROCESSING

A basic premise of the Quick-Look program is that the PC cannot process all incoming data in real time. Because of DOS and central processing unit (CPU) limitations, data collection and data processing are not done at the same time. These tasks could be combined if incoming data rates are sufficiently slow. However, for most of our applications, we have found that the typical PC cannot concurrently do both adequately. If the processes are independent, then the CPU can be fully dedicated to each task separately. This allows access to higher-rate incoming data and provides greater data-processing capability.

To compensate for the limitations imposed by the PC, two techniques can be used to effectively reduce the quantity of incoming data to a manageable level. First, the PCM data streams can be periodically sampled at a controlled rate. This allows the PC's CPU to selectively alternate between acquiring and processing data. Second, data can be contiguously recorded to disk or memory over a given duration of time and then postprocessed. These techniques are described below.

SAMPLED DATA ACQUISITION

Sampled data acquisition is used to provide real-time data-monitoring capability. The incoming PCM streams are periodically sampled to acquire small segments of contiguous data. The segments are quickly processed and displayed to show current conditions. The process is continuously repeated. Up to 135 channels from any combination of incoming PCM streams can be displayed. Each representative value for each

channel is determined by averaging 1 to 10,000 contiguous samples. The user selects channels for display and defines an appropriate averaging interval.

For example, selected channels would be displayed on the monitor in the following format:

```
201:Anemometer #1 (m/s) ..... 1.067E+01 (2.502E-01)
307:Power Supply (volts) ..... 2.502E+00 (6.745E-02)
402:Bending Moment (N-m) ..... 5.678E+02 (3.456E+01)
.
.
```

The first digit of the channel number identifies the PCM stream, and the next two digits identify the data word. The mean and standard deviation values continuously change as data monitoring cycles. The monitor display may lag behind real time by a few seconds, depending on calculation overhead. For the Combined Experiment data streams of Table I, practical data monitor update rates of 1-10 seconds were easily achieved.

CONTIGUOUS DATA ACQUISITION

In contiguous data acquisition, data streams are recorded in real time, with no gaps. Data from up to four streams can be simultaneously acquired to a disk file up to the limit of available disk space. The data blocks are then postprocessed using features of the Quick-Look program.

While contiguous data collection is occurring, no other process can run on the computer. After the block of data is acquired, summary statistics are presented on the monitor display. From these, the user can decide whether the data set meets the necessary criteria.

These data-reduction techniques impose restrictions that the user must be aware of, and they may not be appropriate in certain situations. For example, transients may be missed, or aliasing could be introduced. To provide data values representative of existing conditions, the data segments should be stationary time history records (Bendat and Piersol 1980). The Quick-Look program provides many features that allow evaluation of time series data. It is up to the user to ensure that the data segments are sufficiently long and statistically meaningful to produce adequate results.

For most of our Quick-Look requirements, the limits imposed by the PC-based system are not of concern. In typical field experiments, we have found this system to be extremely useful, especially for monitoring current conditions and conducting channel calibrations. With high-rate incoming data, we do not use this system for full data processing. Usually, we record all PCM data streams independently to provide complete data sets for comprehensive postprocessing, as shown in Figure 2.

DATA BASE OF PCM STREAM CONFIGURATION

The Quick-Look program provides a form into which a set of configuration parameters defining each PCM stream can be input. The parameters are then used to set up decoding hardware to access streams whose channels are requested. The configuration parameters are

1. PCM stream title
2. Number of data words per frame (data channels)
3. Number of sync words per frame
4. Binary sync bit pattern
5. Bit rate in bits/sec
6. PCM data format (Bi-phase L or NRZ)
7. Signal polarity
8. Bits per word
9. Samples to average.

DATA BASE OF CHANNEL PARAMETERS

A data base is kept for each channel of each PCM stream. A maximum of 70 channels per stream is allowed. The data base consists of a set of user-definable parameters and corresponding data. For the Combined Experiment, the following parameters fields are used:

1. Channel description
2. Sensor location
3. Sensor type
4. Sensor ID number
5. Anti-alias filter setting
6. Sample rate
7. Engineering data units
8. Slope (engineering units per count)
9. Offset (engineering units)
10. Range maximum
11. Range minimum
12. Reference channel for calibration
13. Low, zero (mid), and high calibration values
14. Flag to print mean values to a log file
15. Date and time of latest revision

Parameters 2-6 are available for bookkeeping purposes, and other than for comprehensive printouts they are not used elsewhere in the program. Values do not have to be entered in these fields. Parameters 1 and 7-14 are used in various other places in the software. It may be necessary to enter values these fields depending on the program option selected.

The channel data base option of the Quick-Look program provides access to these parameters for any channel on any PCM stream. The user is presented with a form on the screen that displays current parameter values, which can easily be updated or modified. If any changes are made, a new version of the data base file is written and becomes the current version. Parameter 15 is updated automatically if any changes are made in any field.

Previous versions of the channel data base are retained so that a history of the channel, including calibration coefficients, is available. The program allows previous versions to be easily recovered. This is especially useful for postprocessing raw PCM data recorded on tape, allowing ready access to data values in correct engineering units.

RAPID MULTICHANNEL CALIBRATION CAPABILITY

Only linear engineering unit conversions are provided, one slope and offset pair for each channel. The slopes and offsets can be input manually into the channel data base, if known. They can also be generated based on measured data obtained during "calibration runs" and automatically inserted into the channel data base. It is possible to quickly generate and update calibration coefficients for many channels from many PCM streams simultaneously. There are four options for calibration runs:

1. 3-level high/mid/low calibration data
2. 2-level high/low calibration data
3. 1-level zero cals (determines offset only)
4. A function of another "reference" data channel.

For the first two options, PCM count data are collected at the constant calibration levels for a short duration of time and stored in a file. The channel data base contains a value in engineering units which should coincide with the measured count value at each level. The count data are read from a file and compared to the reference values. A least squares regression line is generated from which a slope and offset are found, and correlation statistics are calculated.

For the third option, count values corresponding to the channel zero (or any known level) are stored to a file. The data base zero value is used as a reference, and a new offset is calculated.

For the fourth option, engineering unit data are concurrently measured from a "reference channel" used to generate coefficients for the channels to be calibrated. The relation between the reference channel and the channel to be calibrated is limited to a simple user-defined mathematical function entered in the channel data base. A least-squares regression line is generated to obtain the relation between the two variables. This allows a "ramp" calibration to be done, in which the data values are distributed over a wide range, as opposed to discrete known levels.

Upon completion of a calibration run, the user is presented with a page of summary regression statistics, other information pertinent to the least-squares fit, and new calibration values. The user can opt to accept or decline the calibration coefficients based on these statistics. He or she can also set up criteria that automate the acceptance process using defined tolerances. For example, the user can identify acceptable ranges of standard error and correlation coefficient. If the regression statistics are within the ranges, calibration coefficients are automatically accepted and inserted in the data base. This provides a means to quickly calibrate many channels. It has proven very useful in the Combined Experiment, in which calibrations of 128 pressure channels are required every five minutes of testing.

CONCLUSIONS

In a single PC, the PC-PCM decoding system provides continuous data acquisition to memory or disk from up to four streams simultaneously. A variety of software packages can subsequently be used to read and process the data.

The full complement of boards in a PC permits data handling from a maximum of 16 PCM streams containing up to 62 channels each. The boards are IRIG compatible and are designed for use with standard PCM encoders. The data streams can be accessed by cyclic sampling or simultaneous acquisition or both. Maximum acquisition rates and data storage capacity depend on PC hardware.

Optional analog interface modules can be used in conjunction with the PC-PCM decoder boards. These provide digital-to-analog conversion of up to 8 user-selectable channels per PCM stream, or 32 channels total.

The Quick-Look program, a comprehensive software package designed to work with the PC-PCM hardware boards, is used to manage data from multiple incoming PCM data sources. It provides a way to quickly examine field data in an experiment test environment. Program menus allow easy access to options that facilitate organization, acquisition, processing, and display of information from many PCM data streams.

The Quick-Look program presumes that a PC cannot process all incoming data in real time. It compensates for this by using techniques to reduce the quantity of incoming data to a manageable level. The data-reduction techniques impose limitations that the user must be aware of, and they may not be appropriate in certain situations. However, for most of our Quick-Look requirements, the imposed limitations are not of concern.

In our typical field experiments, we have found the Quick-Look program to be extremely beneficial, especially for real-time monitoring and for conducting multichannel calibrations. The ability to grab contiguous time-series data blocks from multiple streams allows access to high-rate phenomena. Graphic review features provide the test engineer with a means to quickly interpret results. Data bases providing histories of

channel configurations and calibration coefficients are essential for accurate postprocessing of recorded raw data sets.

Incorporating the PC-PCM system into small portable computers simplifies remote test monitoring of PCM data. The complete system provides test engineers with the ability to decode PCM data and perform quick-look data analysis in the field.

REFERENCES

APEX Systems, Inc., 1988, *PCM Decoder Card Manual*, Boulder, Colorado: APEX Systems, Inc.

Bendat, J. S., Piersol, A. G., 1980, *Engineering Applications of Correlation and Spectral Analysis*, A Wiley-Interscience Publication, New York: John Wiley & Sons.

Butterfield, C. P., *Aerodynamic Pressure and Flow Visualization Measurements from a Rotating Wind Turbine Blade*, Proceedings of the Eighth ASME Wind Energy Symposium, Vol. 7, January 1989, pp. 245-255.

Fairchild Weston Systems, Inc., 1985, *PCM Data Collection and Reduction System for the Solar Energy Research Institute: Operating Manual*, Sarasota, Florida: Fairchild Weston Systems, Inc.

Loral Instrumentation, 1987, *D/PAD Mark II Data Processor, Analyzer, Display System User's Manual*, San Diego, California: Loral Instrumentation.

McKenna, E., 1990, *The Wind Research/Cooperative Field Data Acquisition System*, to be published by the Solar Energy Research Institute.

Simms, D. A., 1990, *PC-Based PCM Telemetry Data Reduction System Software*, Proceedings of the 36th International Instrumentation Symposium, May 6-10, Denver, Colorado: Instrument Society of America.

Simms, D. A., and Butterfield, C. P., 1990, *PC-Based PCM Telemetry Data Reduction System Hardware*, Proceedings of the 36th International Instrumentation Symposium, May 6-10, Denver, Colorado: Instrument Society of America.

Strock, O. J., 1983, *Telemetry Computer Systems: An Introduction*, Instrument Society of America, Englewood Cliffs, New Jersey: Prentice-Hall Inc.