

Your Proposal Could Lead to Substantial Cost Savings for Your Plant—Submit it Now!

Oak Ridge National Laboratory (ORNL), on behalf of DOE's Office of Industrial Technologies (OIT), is interested in obtaining proposals from industrial manufacturing plant sites for plant-wide assessments that will lead to substantial improvements in industrial energy efficiency, waste reduction, productivity, and global competitiveness.

The overall goal of such plant assessments is to develop a comprehensive strategy that will significantly increase plant energy efficiency and reduce environmental emissions. In this regard, ORNL strongly encourages industrial sites to work closely with their resource and equipment suppliers, engineering firms, and other third party entities. Funding of up to \$75,000 is available for each project selected with a required industrial cost share of at least 50%.

We are interested in industrial sites that take a comprehensive, plant-wide systems approach to increasing energy efficiency and reducing environmental emissions. Specifically, proposals are sought where teams will be considering the adoption of best available and emerging technology using state-of-the-art tools, information, process engineering techniques, and best practices for operating and planned plant support and process systems. Priority will be given to proposals for plant assessments from industrial sites that fall within the OIT Industries of the Future (IOF) initiative, including: Forest Products, Chemicals, Petroleum, Steel, Aluminum, Metalcasting, Glass, Mining, and Agriculture.

It is expected that the plant assessments will address a variety of generic and industry-specific technology areas, and a variety of plant/process optimization methods. Proposers should also consider demand-side energy management best practices and technology implementation in plant steam delivery and process heating systems, electric-motor systems (including

motors, drives, pumps, fans, blowers), compressed air systems, and heat exchange optimization (e.g., pinch technology), as well as, supply-side options using cogeneration and combined heat and power system technologies.

The results, successes, and experiences from these assessments will be published to encourage other U.S. industrial companies to adopt and implement a comprehensive, plant-wide systems approach to increasing energy efficiency and reducing environmental emissions. In this way, it is desired to increase the market penetration of energy-efficient systems across U.S. industry and to increase industrial energy efficiency, waste reduction, productivity, and global competitiveness. Participating plants will be made aware of, and provided technical assistance to accessing, all OIT emerging technology and best practices, and tools and information resources that could assist the plants in implementing the most cost-effective state-of-the-art technology.

Parties interested in receiving the RFP should contact:

Mitch Olszewski
Oak Ridge National Lab
P.O. Box 2009
Building 9102-1, Mail Stop 8038
Oak Ridge, TN 37831
(423) 574-0770, phone
(423) 576-0493, fax
zmo@ornl.gov, e-mail



An Office of Industrial Technologies
Bimonthly Publication Focusing on
Energy Efficiency Opportunities for Today
www.oit.doe.gov
www.motor.doe.gov

Issue Focus: Motor, Steam, Compressed Air Systems Management

IN THIS ISSUE

Your Proposal Could Lead to Substantial Cost Savings for your Plant—Submit it Now 1
Boiler System Efficiency Improves with Effective Water Treatment..... 2
DOE Industrial Assessment Center Helps Georgia Quarry 4
Data Logging a Plant Compressed Air System 5
Performance Optimization Tips 6
Root Cause Failure Analysis on AC Induction Motors 8
Letters to the Editor 9
Coming Events 10

INSERT:

Steam Challenge Supplement

Energy Matters.

So Don't Wait Any Longer to Get Your Copies.

More than 20,000 professionals like you already know. As subscribers to *Energy Matters*, they receive timely, relevant, whole-systems energy and money-saving information. This knowledge helps them improve operational efficiencies and manage external impacts caused by deregulation from the plant floor to the executive floor.

FREE. There's no catch. No hook.

Energy Matters captures the full spectrum of productivity-enhancing, energy-efficient opportunities for industry. Each bimonthly issue, produced by the U.S. Department of Energy's Office of Industrial Technologies, presents ideas to improve a variety of industrial energy systems such as motor, steam, compressed air, and combined heat and power.

Look to upcoming issues of *Energy Matters* to help you:

- "Sell" energy-efficient projects to management
- Identify the benefits of contracting services
- Assess energy-saving new technologies
- Answer reliability based maintenance issues
- Understand adjustable speed drive technologies

Take a few minutes to read through the enclosed copy of *Energy Matters*. The May issue focuses on motor, steam and compressed air systems management and includes articles on planned upgrades, improving boiler efficiency, and field measurements. You'll also find a supplement devoted to ways to help you improve industrial steam system efficiency.

Start your subscription to this award-winning, free publication by simply completing and faxing back the form on the back of this page. Or you can subscribe on the Web site at www.motor.doe.gov.

Energy Matters
Bringing you tomorrow's technology today.

Energy Matters Subscription Form

Fax to Kevin Pyles at (301) 572-0999

Name: _____

Title: _____

Organization: _____

Address: _____

City/State/Zip: _____

Phone: _____

Fax: _____

E-Mail: _____

Type of Company

Industrial End User SIC _____ Name of Industry _____

OEM

Equipment Distributor

Consultant

Government (Circle type: Federal, State, Local)

Research Organization

Trade Association

Utility

Other

Position in Company

Management

Engineering

Maintenance & Operations

Purchasing

Research

Marketing

Size of Company or Plant Site

Small (<100 employees)

Medium (100-500 employees)

Large (>500 employees)

ENERGY MATTERS

(formerly *Turning Point*) is published bimonthly by the U.S. Department of Energy's (DOE) Office of Industrial Technologies.

Information contained in the newsletter can be reproduced without permission provided due acknowledgement is given (the U.S. Department of Energy's *Energy Matters* newsletter) and a copy of the publication is supplied to the editor.

EDITORIAL BOARD

Bob Asdal, Hydraulic Institute
Floyd Barwig, Iowa Energy Center, representing Compressed Air Challenge
Rob Boteler, representing National Electrical Manufacturers Association
Lynda Butek, representing Electrical Apparatus Service Association
Don Casada, Oak Ridge National Laboratory
Keith Davidson, Onsite Sycom Energy
Steve Darby, Darby Electric
Glenn Hahn, Spirax Sarco
Fred Hart, U.S. DOE, Steam Challenge
Kim Holshouser, U.S. Electrical Motors
Chris Hunter, Johnson & Johnson
Roy Jones, representing Compressed Air and Gas Institute
John Machelor, Macro International
Rick Payton, Rockwell Automation/Reliance Electric
Bill Stafford, Technical Association of the Pulp and Paper Industry
Howard Snyder, Weirton Steel
Chuck Whelan, DuPont

COMMENTS?

Contact:

Julia Oliver, DOE, at (510) 637-1952, or e-mail julia.oliver@oak.doe.gov

Erika Ericksen, *Energy Matters* Editor, at (303) 275-3914, or e-mail erika_ericksen@nrel.gov
1617 Cole Blvd., MS 1713
Golden, CO 80401

Boiler System Efficiency Improves with Effective Water Treatment

By Michael Frasca, Boiler Technology Marketing, Nalco Chemical Company, Naperville, IL

Minimizing energy costs while maintaining high boiler reliability is one of the main objectives of every utility system operator. Optimization of boiler combustion controls, minimizing stack losses, and installation of heat recovery equipment are obvious big-ticket items. Water treatment, although typically a smaller payback item, is also important.

There are many opportunities, as discussed in this article, to improve boiler system efficiency through the use of chemical treatment.

Reduce Boiler Scale

Boiler scale creates a problem in boiler operation because scale typically possesses a low thermal conductivity (relative to a clean metal surface). The presence of scale is equivalent to having a thin film of insulation across the path of heat transfer from the furnace gases to the boiler water. This heat-insulating material retards heat transfer and causes a loss in boiler efficiency. Stack gas temperatures may increase as the boiler absorbs less heat from the furnace gases.

Heat transfer may be reduced as much as 10%-12% by the presence of scale. A scale approximately 1/8-inch thick may

cause an overall loss in boiler efficiency of about 2%-3% in fire tube boilers as well as in the convective sections of water-tube boilers. Even more important than the heat loss is that scale can cause overheating of the boiler tube metal and can result in subsequent tube failures. Costly repairs and boiler outages are the result of such a condition (Figure 1).

Scale formation in boilers can be controlled by chemical treatment in combination with the proper operation and maintenance of all make-up and feedwater pretreatment systems. Phosphates, chelates, and polymers are among the treatments in common use today to condition and/or maintain solubility of scale-forming solids within the boiler.

Optimize Boiler Blowdown Rates

Proper control of blowdown is a critical part of boiler operation. Insufficient blowdown may lead to deposits or carryover, while excessive blowdown will waste water, heat, and chemicals. The American Society of Mechanical Engineers (ASME) has developed a consensus on operating practices for boiler feedwater and blowdown that is related to operating pressure. These suggestions apply for both steam purity and deposition control.

(continued on page 3)

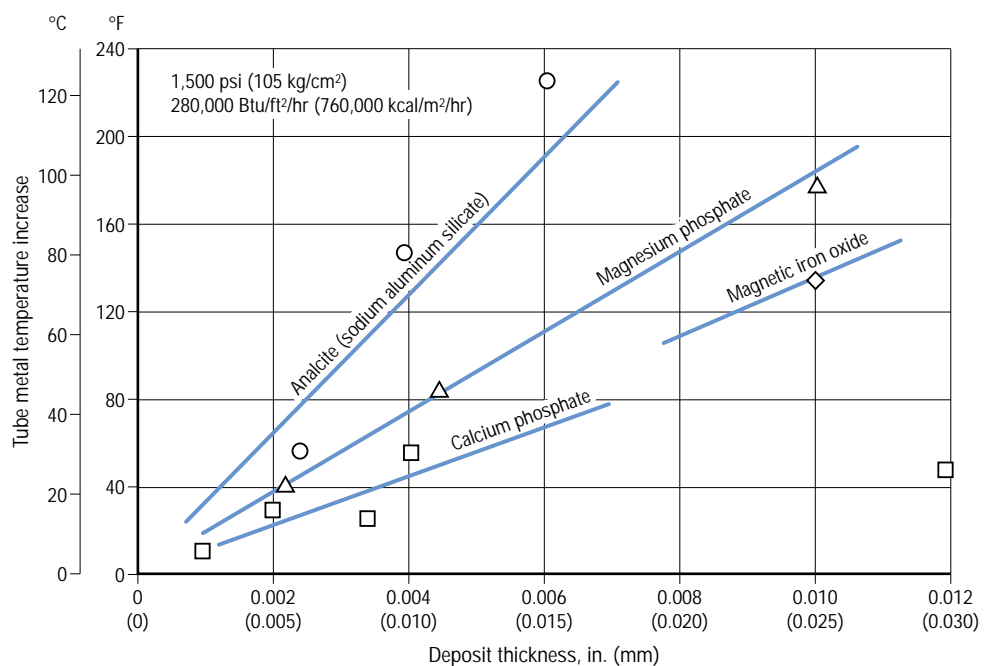

Figure 1. Effect of boiler scale on tube metal temperature.

continued from page 2

The ASME limits are a good starting point in establishing blowdown needs. Operating experience with a particular boiler then determines whether or not it is practical to deviate from these limits. A steam purity study can help set new boiler limits which will minimize solids carry-over, while also maintaining minimum blowdown rates.

Once specific limits for boiler water solids have been set, a practical way is needed to control solids level on a day-to-day basis. Conductivity, TDS, silica, chlorides, and/or alkalinity is often used to control the rate of blowdown. These tests, however, are often subject to interference and may be difficult to measure accurately in high-purity feedwater systems.

An inert fluorescent tracer can be used to accurately measure boiler cycles and chemical feed. Typically, the increased accuracy and confidence from using an inert fluorescent tracer will allow boiler cycles to be increased, resulting in significant savings.

Reduce Iron and Copper Pick-up in the Feedwater

Oxygen scavengers developed within the last 20 years may be more than their name implies. Some provide both chemical oxygen scavenging and passivation of the pre-boiler or feedwater system. (Passivation is the formation of a very thin, dense, protective iron oxide film, commonly magnetite, on the metal surface. Passivation typically increases the corrosion resistance of a metal surface.) These oxygen scavengers are used to prevent corrosion in the feedwater system. Reduced corrosion minimizes the transport of corrosion products to the boiler and also to the superheaters if feedwater is used for attenuation.

Testing under laboratory conditions has determined that carbohydrazide is the best passivating agent at all temperatures, followed by erythorbic acid and then hydrazine. Reduction of feedwater iron

and copper concentrations by carbohydrazide has been confirmed in actual boiler systems.

Reduce Feedwater to the Boiler

The maximum achievable cycles in a boiler is often limited by TDS or conductivity. In boiler systems using sulfite as an oxygen scavenger, switching to a non-sulfite scavenger can reduce feedwater TDS and improve boiler system efficiency. Sulfite is commonly fed to maintain a residual in the boiler water (Table 1). In contrast, the non-sulfite scavenger dosage is based on a small feedwater residual, typically about 1 ppm. In addition, some of the alternative scavengers do not themselves contribute to boiler water TDS or conductivity. For a typical boiler operating at 200 psig, 550,000 lbs/day steaming rate, and 5.5 cycles, the savings from switching to a non-sulfite scavenger would total \$23,000 in fuel costs annually.

Table 1. Recommended Boiler Water Sulfite Residual

Boiler Pressure, Psig [Mpa]	Residual Range, ppm
Below 300 [<2.07]	30-60
301-600 [2.08-4.14]	20-40
600-900 [4.14-6.21]	15-30
Above 900 [>6.21]	Not recommended ¹

¹ Original recommendations extended above 900 psi, however, thermal breakdown of sulfite typically limits modern day use to systems operating below 900 psi.

Steam/Condensate System

One economically attractive method of maximizing energy efficiency and boiler reliability is by increasing the amount of condensate return. Returned condensate, being condensed steam, is extremely pure and has a high heat content. Increased condensate return can improve boiler system economics through water and energy conservation.

As more condensate is returned, less make-up is required, saving on water and make-up water treatment costs. The high purity allows for greater boiler cycles of concentration, thus reducing water and energy losses to blowdown. The high heat content (typically in excess of 180°F) can provide substantial energy savings. Addi-

tional savings will also be noted in reduced water treatment chemicals, water and sewer costs. For a typical boiler operating at 600 psig, 2,400,000 lbs/day steaming rate, and 13 cycles, the savings from increasing the condensate return 10% would total \$132,000 in fuel costs annually.

Corrosion in condensate systems can limit the quality or quantity of returned condensate because of iron and copper corrosion products, which can deposit on boiler heat transfer surfaces. This reduces heat transfer efficiency and could cause tube failure. Condensate corrosion control is required to protect process equipment, lines, tanks, as well as to maintain the condensate as a quality feedwater source. Corrosion of the condensate system can result in increased maintenance and equipment costs, energy loss through steam leaks and loss of process heat transfer efficiency.

To prevent condensate corrosion, volatile neutralizing amines, such as cyclohexylamine, morpholine, and diethylaminoethanol, are typically used to neutralize carbonic acid and raise the condensate pH. These programs are most effective when fed to maintain a minimum pH of 8.5, ideally 8.8 to 9.2. A blend of several amines will assure that corrosion protection is distributed throughout the entire steam/condensate system. Filming amines and a new, patented chemistry are alternative condensate treatments.

Summary

There are many opportunities to improve boiler system efficiency through the use of chemical treatments. Water treatment is an important aspect of boiler operation that can improve efficiency and availability, or result in damage if neglected.

For questions or comments, call Mike Frasca at (630) 305-1625 or send e-mail to mfrasca@nalco.com.

DOE Industrial Assessment Center Helps Georgia Quarry Reduce Maintenance Requirements and Energy Costs

Each year, the Energy and Environmental Management Center (EEMC) at the Georgia Institute of Technology (Georgia Tech) conducts 25 to 40 energy, waste and productivity assessments, partly supported by its role as a DOE Industrial Assessment Center (IAC).

In February 1997, the EEMC, a Motor Challenge Allied Partner, completed an assessment of the Blue Circle Aggregates quarry in Lithonia, Georgia, outside Atlanta. The Lithonia quarry, one of 10 quarries operated by Blue Circle Aggregates in Georgia, produces 1.8 million tons of aggregate and manufactured sand for construction and road building each year. Excavating, moving, screening, and processing these materials consume approximately 4 million kWh annually and create a demand of about 500 kW.

Based on their assessment, the EEMC staff recommended three motor system upgrades for the Lithonia quarry. Implementing the motor system upgrades has reduced yearly energy consumption at the quarry by nearly 250,000 kWh and demand by 81 kW, resulting in cost savings of over \$21,000 per year. These energy and demand savings are 6.2% and 16% of their respective annual figures.

Motor System Upgrades

The three motor system upgrades were initiated in January 1997 after the Lithonia Quarry Manager approached the EEMC

requesting an IAC assessment. Soon afterward, the EEMC presented the results and their recommendations to the Quarry Manager and Blue Circle Aggregates' Director of Environmental Services, who reviewed the report and set priorities for the Lithonia quarry. They were convinced that the combined benefits of reduced maintenance and improved energy and environmental performance were greater than the cost of the upgrades.

Upgrade 1: Reduce Horsepower of Water Pumps

The greatest energy savings resulted from reducing the capacity of three large water pumps. The quarry has two water sources—a quarry pit and a stream some distance away. The EEMC found that the quarry pit could provide all the necessary water for quarry operations. Therefore, reducing the use of the main pump from the stream and two additional circulation pumps reduced power requirements by 140 horsepower (Table 1).

Upgrade 2: Lower Hydro-Cyclone Elevation

The second system upgrade reduced pumping costs by physically lowering part of the 10-element hydro-cyclone unit at the quarry by 80 feet. This upgrade cost approximately \$5,100 and resulted in annual monetary savings of \$3,400—a simple payback of 1.5 years (Table 1).



Water pump at Blue Circle Aggregates' Lithonia quarry.

Upgrade 3: Replace Four Motors with Energy-Efficient Motors

The third recommended upgrade includes replacement of four standard efficiency motors with high-efficiency models upon burnout. The EEMC completed the economic evaluations for this upgrade using MotorMaster+. (Table 1)

The EEMC further recommended that Blue Circle Aggregates change their motor policy to specify that *all* motors operating more than 3,000 hours per year be replaced with high-efficiency motors upon burnout. Doing so would have an average payback of about 2.4 years.

Blue Circle Aggregates' On-going Upgrades

After completing the Lithonia quarry assessment, the EEMC completed assessments at two other Blue Circle Aggregates facilities. Since then, Blue Circle Aggregates' own staff has completed five more assessments of their own. "They did need some additional assistance after we submitted the report for the Lithonia quarry," says John Adams, Georgia Tech EEMC Director, "but Blue Circle Aggregates' corporate Environmental Manager has kept the project alive and full of vitality."

Blue Circle Aggregates' current plan is to implement at each plant upgrades similar to these three quarry upgrades.

(continued on page 5)

Table 1: Motor System Upgrade Savings

Motor	HP	kW Savings	kWh Savings	\$ Savings
Upgrade 1: Reduce Horsepower of Water Pumps				
Water Pump #1	50	20.1	60,400	\$ 5,260
Water Pump #2	75	28.0	89,900	7,320
Water Pump #3	15	9.8	29,500	2,570
Upgrade 1 Totals	140	57.8	179,800	\$15,150
Upgrade 2: Lower Hydro-Cyclone Elevation				
Upgrade 2 Totals	N/A	13.1	39,300	\$ 3,400
Upgrade 3: Replace Four Motors with Energy-Efficient Motors¹				
Crusher	200	2.4	7,218	\$ 629
Pump #2	150	2.4	7,296	636
Pump #3	200	2.4	7,218	629
Pump #6	140	2.6	7,718	673
Upgrade 3 Totals	690	9.8	29,450	\$ 2,567
Grand Totals	837	80.8	248,640	\$21,117

¹ Savings based on 3,000 hours of operation per year and replacement upon motor failure.

continued from page 4

Georgia Tech's Energy and Environmental Management Center

Because of its experience with the type of operations targeted by DOE's Office of Industrial Technologies, the EEMC became a DOE Industrial Assessment Center (IAC). As an IAC for almost 20 years, the EEMC has provided over 650 in-depth IAC assessments at no-charge to eligible manufacturing plant sites.

John Adams feels it was an easy progression from being a Department of Energy IAC to becoming a Motor Challenge Allied Partner. As a Motor Challenge Allied Partner, the EEMC conducts seminars and workshops and performs in-plant energy audits. "We routinely demonstrate the MotorMaster+ software then leave the customer with a copy for their own use," says Adams. "We like to teach by example," he adds.

Contact John Adams at (404) 894-4138.

DOE'S INDUSTRIAL ASSESSMENT CENTERS

As one of 29 Industrial Assessment Centers based at universities around the country, the EEMC provides energy, waste, and productivity assessments at no charge to small and medium-sized manufacturers, many of which are Motor Challenge Partners. These assessments help manufacturers maximize energy efficiency, reduce waste, and improve productivity. Average savings of greater than 10% of annual utility costs typically result from implementing the assessment recommendations.

To be eligible for an IAC assessment, a manufacturing plant must meet the following criteria:

- Primary business within Standard Industrial Classification (SIC) codes 20-39;
- Located within 150 miles of an IAC host campus;
- Gross annual sales less than \$75 million;
- Fewer than 500 employees at plant site;
- Annual energy bills greater than \$75,000 and less than \$1.75 million; and
- Employ no professional, in-house staff able to perform the assessment.

For information about an energy audit for your plant, please call (800) 862-2086.

Data Logging a Plant Compressed Air System

By Robert E. Wilson, ConservAIR Technologies Co. LLP

While pressure readings at the point of generation provide important information, they do not portray a complete and accurate picture of the system's overall performance. A system can have very stable pressure in the compressor room while experiencing major pressure fluctuations in the production area. Fluctuations can be localized or affect the entire distribution pressure. If fluctuations affect production, the typical response is to increase compressed air supply, which increases operating costs.

A compressed air system cannot be evaluated or controlled from the supply side; performance must be measured on the production floor. Evaluating air system efficiency requires a comparative review of both supply-side and demand-side pressure profiles.

Data logging is an excellent way to define performance and identify problems in an industrial compressed air system. However, to be useful, data acquired must be correctly interpreted.

Define Specific Objectives

Before data logging your system, define your objectives. Keep the objectives specific to key issues. Focus on the information desired not the actual data. Put away preconceived notions about current performance and solutions.

Key questions as they relate to one point of pressure data are:

- Is pressure too high or too low?
- What is too low?
- Is pressure consistent?
- How consistent should it or can it be?
- When pressure increases, why does it increase?
- Did pressure increase because another compressor loaded up or because an event demand went away?
- If pressure decreased, what was the cause?
- Is the system driven by the compressors, are the compressors responding to demands, or both?

To make data meaningful, you must ask the right questions, then compare and evaluate with other pressure point data in a total system analysis.

Today's data logging equipment simplifies the review process and offers a valuable tool for those who have some knowledge

and experience with compressed air systems. Used properly, a data logger defines your system's pressure profiles and shows how the system is operating.

Develop Test Procedures

After determining objectives, develop a test procedure. Select, identify, and list monitoring points and parameters. Also, specify sampling rates and the duration of the data logging.

Pressure is the easiest and most definitive measure of system performance. Other variables such as barometric pressure, temperature, fixed volume, moisture content, demand load profile, and leaks remain relatively constant for a specific system and duration of data gathering. Therefore, the conclusions derived from a comparative evaluation are valid.

Amperage readings are relatively easy to log. Flow and kW can then be estimated based upon the compressor manufacturer's published data. Again, if the same assumptions are used before and after, the conclusions derived from the comparative evaluation will be valid.

At a minimum, pressure must be logged at the generation point in the compressor room(s), at representative points in the piping distribution system, and at critical-use points.

A typical data logger allows four or more simultaneous measurements. Multiple loggers can be used at different locations within the air system. The key to proper interpretation is to sample data simultaneously at representative locations in the compressor room(s), piping header(s), and use point(s). The sampling must accurately represent your operation.

Instantaneous and Trending Operating Profiles

A pressure drop shows a change in pressure as it relates to a point in time. A trending profile shows the pressure change across the system.

Instantaneous profiling helps determine dynamic peak, average, and valley demands of the system and the amplitude of pressure fluctuations. Trending should be conducted over a time period representative of the production schedule being evaluated—typically over 24-hour periods and off-peak times. A comparison of samplings in various locations is used to determine pressure gradient across the system.

(continued on page 9)



Performance Optimization Tips

Field Measurements—
Practicalities and Pitfalls in
a Parabolic Context



By Don Casada,
Motor Challenge
Program, Oak Ridge
National Laboratory

Note: This article,
focusing on under-
standing the chang-

ing picture of system operations, is the third of a series dealing with potential pitfalls in field measurements of motor systems. The first appeared in the November 1998 issue of *Turning Point*.

Centrifugal loads, such as pumps, fans, and compressors are responsible for a large fraction of industrial electrical energy consumption (1). The opportunities for reducing energy consumption in these systems are often significant. Any effort to do so inherently requires three fundamental pieces of information:

- The big picture—clearly identified functional requirements of the system.
- An understanding of how the picture changes over time.
- Actual measurements in the field.

The first two elements, which should always precede and provide the focus for actual measurements, were covered in previous articles that appeared in the November 1998 *Turning Point* and the March 1999 issue of *Energy Matters*. This issue will begin covering the third, subsidiary element.

As an employee at a national laboratory, I occasionally get involved in experimental testing and analysis. Since the goal of the testing is to produce useful and reliable test results, a good deal of attention is paid to instrumentation issues such as accuracy, range, calibration, proper physical configuration, etc., as well as test protocols. If an important parameter cannot be

monitored with already installed instruments, the facility is modified to add the needed equipment. Details are important, since experimental accuracy is of premium value. Fortunately, professional societies, such as the American Society of Mechanical Engineers (ASME), the Hydraulics Institute, and the Institute of Electrical and Electronics Engineers (IEEE) have written excellent testing standards (2, 3, 4, 5) that address instrumentation and procedural issues.

In many industrial systems, little thought is given to process monitoring issues *unless* the parameter to be monitored is critical to product quality or quantity. For example, if a pumping system is used to remove heat from another process, little attention may be paid to instrumentation issues in the pumping system itself either before or after the system is put in service. This is natural, since the system exists to support the process, not experimental testing. As a result, the process instrumentation that does exist is frequently in undesirable locations (such as a flow meter located two pipe diameters downstream of a control valve), and it is seldom, if ever, calibrated. So while the basic principles on which the test standards are founded are certainly valid in the real world, the supporting instrumentation frequently is not.

If we are to even estimate potential energy reduction opportunities in centrifugal systems, parameters such as flow rate, pressures, and electrical power must be known. Facility managers and operators are uniformly unenthusiastic about cutting or drilling holes in pipes to install meters if the system has been meeting the process goals. In the absence of reliable permanently installed instruments, how does one go about measuring or estimating critical performance parameters in these systems?

Pumping Systems Field Monitoring
The balance of this issue and subsequent issues of this column will discuss alternative methods of either measuring or estimating important energy-related parameters in pumping systems¹ when less than ideal instrumentation is encountered.

From the following expression of overall pump and motor efficiency, which is simply the ratio of the fluid power to the electric input power, the primary parameters of importance in pumping systems are self-evident:

$$\eta_t = \frac{H \cdot Q \cdot \gamma}{P_e}$$

where η_t is overall efficiency, H is the head, Q is the volumetric flow rate, γ is the fluid specific weight, and P_e is electrical input power.

From a practical standpoint, fluid temperature and rotational speed are parameters that are also important to monitor. Starting with head in this issue, each of these elements will be discussed in this column. The focus will be on some practical field issues; a few potential pitfalls and tips based on personal anecdotal experience will also be noted.

It should be noted that References 2 and 3 standards provide excellent detailed discussions on a variety of practical issues related to pump testing that will not be repeated in these columns.

Pump Head

The pump head accounts for the difference in the sums of three elements of energy per unit mass between the pump suction and discharge: pressure, elevation, and velocity. References 2 and 3 as well as many textbooks provide detailed discussions on the individual terms. Some practical aspects of the pressure element of head are treated below. The elevation and velocity elements will be discussed in a subsequent column.

Pressure

In most industrial systems, the pressure component is the dominant head term (the others can't be ignored, however, especially in low head pump applications). Threaded test connections are fairly common in the field, particularly in the pump discharge line—a point where you're also most likely to find a permanently installed gauge.

(continued on page 7)

continued from page 6

Unfortunately, sometimes there are other devices between the pump and the gauge, such as a discharge check or control valve. But all isn't lost if this is the case—the head loss across the valve can be estimated from manufacturer (preferred) or generic performance curves once flow rate is known (or estimated). It is also important to note that the pressure *downstream* of a throttled discharge valve is actually a better indication of what the system *needs* than is the pressure at the pump discharge. If pressure can be measured upstream and downstream of the valve, an immediate indication of potential energy savings from eliminating throttling losses can be established from the following expressions of fluid power:

$$P_{fi} \text{ (hp)} = \frac{\text{gpm} \cdot \text{head loss (ft)} \cdot \text{s.g.}}{3690}$$

or

$$P_{fi} \text{ (kW)} = \frac{\text{m}^3/\text{hr} \cdot \text{head loss (m)} \cdot \text{s.g.}}{367}$$

where s.g. is specific gravity.

The actual electrical power associated with the throttling loss is typically 1.3 to 2 times this value because of inefficiencies in the motor and pump.

Test pressure gauges, rather than permanently installed gauges, should be used if at all possible. It has been my observation that a large fraction of permanently installed gauges, particularly in the absence of a good calibration program, are unreliable. On many occasions, I've found gauges whose pressure indications don't change when removed from the process—even when the needle exhibited some "wiggle" (suggesting the gauge was responding to pressure fluctuations in the system) when connected. The gauge shown in Figure 1 is such an example.

Fortunately, there is usually an instrument isolation valve where permanently installed

gauges are located, which makes for a more pleasant permanent gauge removal and test gauge installation experience (a little dry humor there). These valves not only simplify test gauge installation—they can also be throttled to dampen pressure fluctuations that often exist in pumping systems, making the job of gauge reading a little easier. But care is needed when doing this—the valves are often nearly completely closed to achieve the desired damping, and it is very easy to go to the fully isolated condition. Should the valve completely isolate the gauge from the process, the gauge will continue to read the pressure that existed at valve closure (unless there's leakage around the gauge threads or the valve seat), which may or may not represent actual system conditions. A good way to use the valves for damping is to start with them fully closed (such as when you're installing the test gauge) and with pressure relieved from the stub between the valve and the test gauge. Then gradually crack the valve open and stop when you first see a change in the indicated pressure. A small needle valve inserted between the gauge and the test connection is much easier to use in this way than the gate or ball valves often used as isolation devices in the field.

Hydraulic snubbers are also used sometimes to reduce flutter in gauge indication (as well as to protect the gauge from pressure spikes, such as water hammer). If

used, a test snubber known to be in good shape is recommended instead of a possibly degraded (plugged) permanent one.

My personal preference for pressure readings is a small test transducer (such as shown in Figure 2), which provides an electrical output, such as 1 millivolt per psig. The average transducer signal can be monitored on a multimeter with minimum/maximum/averaging capability, eliminating the need for a valve or hydraulic snubber pressure damping and/or "eyeball averaging". By collecting pressures in this way, the range of pressure fluctuations can also be noted (using the minimum and maximum values). Significant pressure fluctuations may indicate unstable pump and/or system operation, information worth noting on its own merits.

Comments/questions welcome by e-mail: a85@ornl.gov.

¹ Although tailored to pumping systems, much of what is discussed can either be applied directly or in analogous fashion in other centrifugal load systems.

References

- 1) United States Industrial Electric Motor Systems Market Opportunities Assessment, U.S. DOE, December 1998.
- 2) ASME/ANSI Performance Test Code 8.2-1990, Centrifugal Pumps.
- 3) ANSI/HI 1.6-1994, Centrifugal Pump Tests.
- 4) ANSI/IEEE Std. 120-1989, IEEE Master Test Guide for Electrical Measurements in Power Circuits.
- 5) IEEE Std. 112-1991, IEEE Standard Test Procedure for Polyphase Induction Motors and Generators.



Figure 1. Test pressure gauge.



Figure 2. Test transducer.



Root Cause Failure Analysis On AC Induction Motors

By John M. Machelor,
Motor/Drives Systems
Specialist, Motor Challenge
Program, MACRO International Inc.



This is the fourth in a series of articles by Mr. Machelor. In the January 1999 issue, John concluded his discussion of the most common electrical failure modes

of induction motors and how to identify their root causes. The present article shifts the focus to mechanical motor failures. The next article will continue our investigation of AC induction motor bearing failures.

Mechanical-related failures of induction motors have a most common (70% to 80% of all failures) mode, which is bearing failures. These have many direct causes, all of which can again be traced to a root cause. The important thing to note is that the vast majority of all bearing failures are easily preventable.

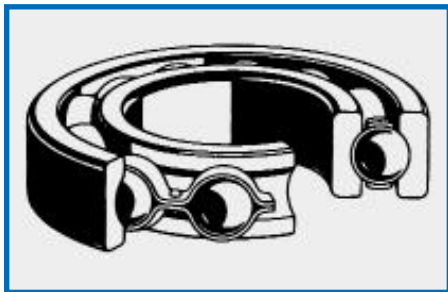

Figure 1. Typical anti-friction ball bearing.

We will focus our attention on anti-friction bearings, the most common type found in NEMA AC induction motors. Specifications for the design of anti-friction bearings are covered by the Anti-Friction Bearing Manufacturers Association, Inc. (AFBMA). Anti-friction bearings are called rolling element because they all consist of an inner and an outer ring (race) encircling some type and number of rolling element. The elements are either balls or various shaped rollers. Figure 1 depicts a typical anti-friction ball bearing. As we discuss the damage to and modes of failure of anti-

friction bearings, one critical characteristic of them will stand out—except for the lubricating film set up by the grease or oil in the bearing, the inner and outer races can (and often do) come into metal-to-metal contact with the rolling elements!

Bearing damage leading to ultimate failure can occur when a motor bearing is motionless or rotating. Let's examine one of the most common types of damage incurred by non-rotating bearings.

False Brinelling: (See Figure 2.) This condition can occur whenever a non-rotating bearing is subjected to external vibration. (Note: There is another type of brinelling called true brinelling that occurs in rotating bearings. Damage to rotating bearings will be discussed in a future article.) When the bearing isn't turning, a protective oil film cannot form between the races and the rotating elements. Thus, there can be metal-to-metal contact between the races and rotating elements, and the small, relative motion between these parts causes wear marks on both races at the location of each rotating element. False brinelling can occur during transportation (typically truck or rail) and during motor storage if the storage area is subject to vibration. False brinelling occurs frequently with the bearings of motors installed on "spare" or "backup" systems in the plant. A typical example of this is parallel motor/pumps where one system is considered to be the primary system and the other system only a backup. The primary system may run for weeks, months, or even longer before the backup system is ever energized. The problem is that even though the backup is not running, it is actually "piped" into the system. Vibrations associated with the running system are being constantly transmitted to the backup system. Thus, severe false brinelling can occur on both the backup motor and pump bearings.

Several years ago, I encountered this "parallel pump" situation at a chemical plant where I was doing a system survey. This facility had literally several hundred primary/backup pump arrangements and their maintenance team admitted that they could not remember the last time some of the backup systems had been used. With this history in mind, I suggested a random

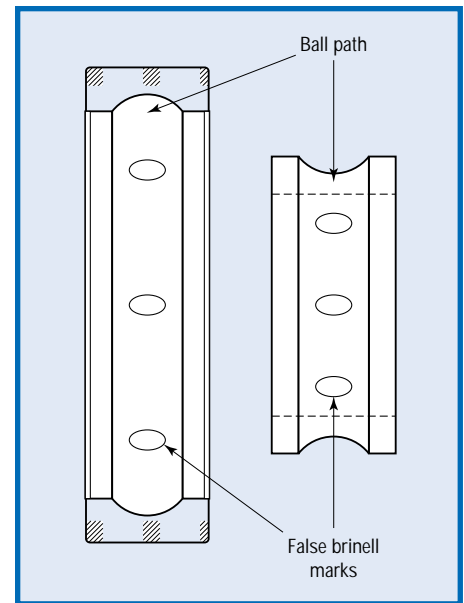

Figure 2. False brinelling.

energizing of ten backup systems which maintenance assured me were "ready to go". Unfortunately, they were right. Of the ten backup systems we energized, seven failed within a day, two failed within a week, and the remaining one managed to last 3 weeks. In all ten cases, a bearing on either the motor or the pump seized up (froze). Disassembly of all ten motors and pumps revealed that all the bearings had severe false brinelling (in addition to corrosion, rust, and loss of lubricant, all to be discussed later). The maintenance team was not expecting failures at this rate, and admitted that on occasions when the primary system failed, the backup system never seemed to last very long.

Tips to Avoiding False Brinelling
The root cause of false brinelling is lack of knowledge that it is a problem as well as lack of a routine maintenance program. Root solutions thus involve becoming knowledgeable on the subject as well as establishing a routine maintenance program for your motors and driven equipment. To this end, here are some "tips" on avoiding this bearing failure cause:

- During transportation of motors (or any type of rotating equipment which utilizes anti-friction bearings), make sure

(continued on page 9)

False Brinelling

continued from page 8

the shaft is "blocked" to prevent axial or radial movement. Blocking eliminates the clearance between the races and the rotating elements in the bearing and thus prevents these parts from "banging" against one another and causing wear.

- Choose storage locations as far away as possible from sources of external vibration. For example, locating a rotating equipment warehouse adjacent to a ball mill is not a good idea. In addition, turn the shaft of all stored rotating equipment at least once a month. Turning the shaft moves the rolling elements of the bearing to a new position with each turn, and also redistributes the settled lubrication grease/oil throughout the bearing.
- In any rotating equipment plant system that has a backup or spare system, there is no reason to designate one system as the "primary" and the other as the "backup". Each system should "share the load" equally. Thus, establish a schedule to run each system roughly half the time, switching at least once a week.

Readers are welcome to send questions, comments, or suggestions to John Macheloro at:

E-mail: jmachelo@macroint.com or macrojmm@aol.com

Phone: (540) 639-4271

Fax: (540) 639-4272

Letters to the Editor

NEW *Energy Matters welcomes comments from readers. Letters should be typewritten and must include the author's full name, address, association, and phone number. Letters should be limited to 200 words. Address your letter to:*

*Michelle Mallory,
Letters to the Editor
NREL, MS 1713
1617 Cole Blvd.
Golden, CO 80401
or e-mail to
michelle_sosa-mallory@nrel.gov*



We publish letters of interest to our readers on related technical topics, comments, or criticisms/corrections of a technical nature. Preference is given to letters relating to articles that appeared in the previous two issues. Letters may be edited for clarity, length and style.

Motor Repair Efficiency Loss

Recently an article in *Energy Matters* (The Northeast Premium Efficiency Motor Initiative, January 1999) mentioned that rewinding a motor results in a 2% efficiency loss. This assumption of efficiency loss is frequently reported in major rewind studies and reflected in default software calculations.

In fact, an efficiency loss after rewind may occur—but not when repairs are performed correctly. At Advanced Energy, the first motor test lab in the nation to receive accreditation by the National Voluntary Laboratory Accreditation Program (NVLAP)

for motor efficiency testing of 1-150 hp motors, we have conducted over 700 IEEE 112 Method B motor efficiency tests and provided testing services to nine motor manufacturers with a notable precision of repeatability at $\pm 0.2\%$.

Our findings? Certain shops are capable of maintaining or even improving motor efficiency during repair. A motor repair facility with a recognized quality program in place can provide repairs with no loss of efficiency after rewind. The current recognized motor repair quality programs include ISO-9002, EASA-Q and Proven Excellence Verification (PEV).

The savings realized if post-repair efficiency loss is eliminated have been documented. According to the Department of Energy, improved rewind practices have potential energy savings of 4,778 GWh/year—equal to \$230 million—to all American industrial manufacturing facilities. A well-repaired motor also reduces costly downtime and eliminates unscheduled interruptions to production lines, which further reduce operating costs.

Please call me at (919) 857-9013 with questions, or e-mail me at jfarlow@advancedenergy.org.

Jeff Farlow, Motor Test Engineer
Advanced Energy, Raleigh, NC

How have you applied information from this newsletter on the job? Send us an e-mail: www.motor.doe.gov.

Data Logging

continued from page 5

The Action Plan

Once you compile the necessary information, you can draw some conclusions about your system's performance and develop an action plan to improve its overall operation. Consider these items:

- Use the data to determine your system's peak and average air demands. If you identify a pattern of fluctuating pressure at points of use or wide pressure variations during a production cycle, consider using controlled compressed air storage using intermediate flow control and receivers.
- The pressure gradient documents the air distribution system's performance. Define techniques to reduce sustained

gradient to the accepted level of 1.5-2.0 psid across the air distribution system.

- Compressor discharge pressure and load profile data provide information about part-load performance. Additional storage can be engineered to improve the load/unload cycle. You might also network compressors using a compressor sequencer to direct part-load performance.
- Data from dynamic use points reveals information about piping and connections. Develop a schedule for upgrades and repairs on piping and point-of-use tools throughout the system. Use these results to develop standards and establish "Best Practices" for system management.
- The power consumption profile clearly defines your company's financial investment in compressed air generation.

Evaluate the cost effectiveness of remedial actions based upon this investment.

- Use all data collected, summarize findings, and conduct a cost/benefit analysis of your recommendations. Data measurement and testing can be repeated for future evaluation of the compressed air system.

To find out about your system's performance, go out on the floor where air is consumed, and measure what is happening.

More information is available in Compressed Air Management by Tom Taranto. Contact Bob Wilson at (800) 336-2285 for information about the book or other questions related to this article.

See Coming Events on page 10 for upcoming workshops on the Fundamentals of Compressed Air Systems.

Coming Events



UNDERSTANDING PUMP SYSTEMS/PSAT WORKSHOPS

The following sessions present the fundamentals of optimizing industrial and municipal pump systems. The workshops will present case studies and will focus on Pump System Assessment Tool (PSAT).

- June 6 in Milwaukee, WI
- June 20 in Chicago, IL
- August 29 in San Diego, CA

Call Anna Maksimova at (360) 754-1097, ext.100 for more information.

ADJUSTABLE SPEED DRIVE APPLICATION WORKSHOPS

These workshops address the fundamentals of ASDs and demonstrate the ASDMaster software.

- June 1-2 in Reading, PA
- June 10 in Springdale, AK

Call Anna Maksimova at (360) 754-1097, ext.100 for more information.

MOTORMASTER+ SOFTWARE DEMONSTRATION

This demonstration of MotorMaster+ software will be at the American Water Work's Association's Annual Conference.

- June 20-24 in Chicago, IL

Call Anna Maksimova at (360) 754-1097, ext.100 for more information.

FUNDAMENTALS OF COMPRESSED AIR SYSTEMS

These 1-day Compressed Air Systems training seminars are targeted to plant engineers and maintenance personnel who are responsible for ensuring optimum performance of compressed air systems.

- | | |
|--------------------------------|--------------------------------|
| ■ May 12 in Allentown, PA | ■ June 8 in Pittsburgh, PA |
| ■ May 13 in Knoxville, TN | ■ June 11 in San Diego, CA |
| ■ May 21 in Baltimore, MD | ■ June 11 in Greenville, SC |
| ■ May 26 in Salt Lake City, UT | ■ June 11 in Richmond, VA |
| ■ May 28 in Dallas, TX | ■ June 14 in San Antonio, TX |
| ■ May 28 in Nashville, TN | ■ June 15 in Kansas City, KS |
| ■ June 3 in Detroit, MI | ■ June 17 in Phoenix, AZ |
| ■ June 4 in Atlanta, GA | ■ June 22 in Oklahoma City, OK |
| ■ June 4 in Philadelphia, PA | ■ June 22 in Tampa, FL |

For information or a registration form, call (800) 862-2086.

ENERGY EFFICIENCY FORUM FOR WATER/WASTEWATER FACILITIES

The goal of this forum is to help managers and operations personnel of municipal and industrial systems find workable energy management solutions.

- August 29-31 in San Diego, CA

Call Laura Boland at (918) 831-9179 for more information.

This document was produced for the Office of Energy Efficiency and Renewable Energy at the U.S. Department of Energy (DOE) by the National Renewable Energy Laboratory, a DOE national laboratory.
DOE/GO-10099-589 • May 1999



INFORMATION CLEARINGHOUSE

Do you have questions about using energy-efficient electric motor systems? Call the OIT Challenge Programs Information Clearinghouse for answers, Monday through Friday 9:00 a.m. to 8:00 p.m. (EST).

HOTLINE: (800) 862-2086

Fax: (360) 586-8303, or access our homepage at www.motor.doe.gov

DOE Regional Support Office Representatives

- Tim Eastling, Atlanta, GA, (404) 347-7141
- Lili Griffin, Boston, MA, (617) 565-9714
- Julie Nochumsom, Chicago, IL, (312) 886-8579
- Gibson Asuquo, Denver, CO, (303) 275-4841
- Julia Oliver, Seattle, WA, (510) 637-1952
- Maryanne Daniel, Philadelphia, PA, (215) 656-6964



Printed with a renewable-source ink on paper containing at least 50% wastepaper, including 20% postconsumer waste

ENERGY MATTERS

U.S. Department of Energy
EE-20, 5G-067
1000 Independence Avenue, SW
Washington, DC 20585

First Class
U.S. Postage
PAID
Permit No. 258
Golden, Colorado

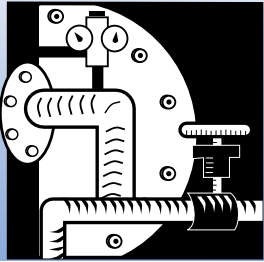

STEAM CHALLENGE

A Special Supplement to *Energy Matters*

Steam Challenge Committee Members

- American Boiler Manufacturers Association
- Armstrong International
- BASF Corporation
- Bethlehem Steel Corporation
- Consortium for Energy Efficiency
- Coors
- Council of Industrial Boiler Owners
- Duke Solutions
- DuPont
- Energy Center of Wisconsin
- Engineered Solutions
- Electric Power Research Institute
- Gas Research Institute
- Georgia-Pacific
- Gestra
- Honeywell, Inc.
- Institute of Textile Technology
- International District Energy Association
- Iowa Energy Center
- Knauf Fiber Glass
- NALCO Chemical
- National Board of Boiler and Pressure Vessel Inspectors
- National Insulation Association
- North American Insulation Manufacturers Association
- New York State Energy Research and Development Authority
- Plant Support and Evaluations
- Rock Wool Manufacturing
- Rohm-Haas
- Spirax Sarco, Inc.
- Swagelok
- Trigen Energy
- Utah Steam Technology Coalition
- Yarway Corporation

Helping Industry To Be Steam Smart

Steam Challenge is a voluntary, technical assistance program to help U.S. industry become more competitive through increased steam system efficiency. Its goal is to promote a systems approach in designing, purchasing, installing, and managing boilers, steam distribution systems, and steam applications. For any end-user of steam, Steam Challenge provides credible resources to help improve steam systems, enhancing process operation and reducing fuel costs.

Steam Challenge is co-managed by the U.S. Department of Energy (DOE) and the Alliance to Save Energy, a national non-profit working on energy issues. The program is directed by a group of industrial end users, equipment suppliers, and organizations involved in the steam marketplace, acting together to promote the comprehensive upgrade of industrial steam systems. These are listed at left.

Optimization of industrial steam systems represents one of the largest non-process, industrial energy opportunities, with improvements of 30% readily achievable in typical plants through the introduction of a best practice approach. Steam accounts for \$25 billion per year of U.S. manufacturing energy costs and 201 million metric tons of carbon equivalent (MMTCE), representing 13% of total U.S. emissions and 40% of U.S. industrial emissions.

Lack of unbiased information has been a primary barrier to realizing substantial improvements in efficiency, reliability, productivity, and safety. Often, plant operators may not have the resources to devote to better system management.

Steam Challenge Provides:

- Technical resources and assistance
- Lists of commercial training opportunities
- Case studies
- Lists of equipment providers
- Information to make the case on improving steam system management

How Companies Can Become Involved:

- Implement steam system projects
- Participate in or sponsor workshops to raise awareness of efficiency opportunities
- Submit data for a case study
- Use Steam Challenge documents and literature for their own clients and workshops

Contact the Steam Challenge by phone at (800) 862-2086, or e-mail at steamline@energy.wsu.edu. Visit the Web site at www.oit.doe.gov/steam.

Steam System Optimization

By Bob Aegerter, Equistar Chemicals, L.P.

This article is condensed from a technical paper presented at the 1998 Industrial Energy Technology Conference Steam Session. For the full paper, call (800) 862-2086.

Using today's energy costs, the incremental cost of generating 1,000 lb./hr. of steam is typically \$25,000–\$35,000/year. This article explores numerous opportunities that may exist in your plant to save several thousand pounds per hour of steam for little or no cost. After several of these projects are implemented, the total savings can be significant.

Develop a Steam Balance

To be able to optimize the steam system, you must understand the system. Developing an accurate steam balance of actual operating conditions is an excellent tool for understanding your steam system. Special attention should be made to accurately measure steam flows through steam let down stations and atmospheric vents for both summer and winter operating conditions.

Balance Steam Excess or Deficit

Typically, a plant will either vent excess low-pressure steam or let down steam to meet low-pressure steam demand. If your plant is large and has several operating areas with independent steam systems, some areas may have an excess of low-pressure steam and other areas may have a deficit. To optimize a steam system, the plant must be integrated as much as possible so that one operating area's excess steam can eliminate the deficit of steam in another area. Reducing steam costs should be a continuous process of eliminating sources of excess low-pressure steam until a steam deficit exists and then implementing heat recovery projects to create a condition of excess low-pressure steam. Use the steam balance as the blueprint to coordinate projects, so large amounts of steam are never vented.

Eliminate Excess Steam

Steam is vented from a pressure control valve when the amount of steam entering the header exceeds the amount of steam

required to maintain the pressure controller's set point. A better solution than utilizing excess steam, which costs less and usually yields better savings, is to eliminate or reduce steam entering the steam header. A steam balance is an excellent tool to identify the steam sources. To eliminate excess steam, a plant can:

Shut down turbines. The easiest solution to eliminate excess steam is shutting down steam turbines that exhaust into the header and start up the motor-driven spare equipment. Often, this is enough to eliminate the venting. Shutting down steam turbines may not be the most cost-effective solution because an electric motor is now being operated. If excess steam can be eliminated without shutting down steam turbines, other solutions should be pursued. If the plant's electrical rate schedule includes heavy penalties to creating new peak demands, consider setting new electrical peak demands when turbines are shut down and motors started up.

Check leaking valves. To eliminate the excess steam condition, all sources of steam that contribute to the excess steam condition must be identified. The surplus steam may be from a higher-pressure steam header. One of the best places to look is steam let down control valves. If a let down control valve is open from a higher-pressure header and steam is being vented at a

lower pressure level, steam is at excess at the higher steam pressure level. Sources of steam supplying the higher-pressure header must be investigated. If the steam let down control valves are closed and steam is being vented, the let down valves may be leaking, contributing to the excess steam.

The easiest way to determine a valve leak is to isolate the control valve and then observe the steam vent to see if the vent flow decreases. Replacing a leaking valve with an ANSI class V control valve can be justified over repairing a standard shut-off valve. Class V control valves seat much tighter and will have a positive seat much longer than standard control valves.

Steam traps that discharge into a steam header should be checked for proper operation. Badly leaking steam traps can over pressure a steam header.

Examine turbines. If let down valves are not contributing to the excess steam problem, steam turbines exhausting into that header should be examined. Hand valve positions on steam turbines should be initially examined. Typically, hand valves are opened up when the turbine is new and left open. Operating a steam turbine with hand valves open when additional horsepower is not needed causes the turbine to use higher steam flows than required. Open valves should be closed while

(continued on page 3)

Don Meadows, TAPPI Journal



Many low-cost opportunities exist in your plant for steam system savings.

continued from page 2

checking the turbine's speed. If the turbine maintains operating speed after hand valves are closed, the valves should remain closed. Hand valves should be operated in either fully open or fully closed positions. They are not meant for throttling steam.

Upgrade turbines If hand valves are closed, check the nozzle block pressure. If there is a pressure drop across the governor valve of more than 10% of the steam inlet pressure, the turbine is over designed and could be rerated to operate more efficiently. Usually, this requires installing a new nozzle block. Rerating a steam turbine is relatively inexpensive and can be justified if the turbine is causing 1,000 lb./hr. of steam to vent to the atmosphere. Work with the steam turbine's manufacturer to obtain a proper re-rate.

Although more expensive than rerating an existing turbine, it may be necessary to replace a steam turbine with a more efficient turbine or an electric motor driver to obtain the required steam flow reduction. When replacing a steam turbine, efficiency should be the prime concern. Typically, single-stage steam turbines operate most efficiently in the 5,000-6,000 rpm range. Most rotating equipment operates at either 1,800 rpm or 3,600 rpm. To get the desired additional turbine efficiency, it may be necessary to speed the turbine up with a gearbox. The additional cost of purchasing and installing the gearbox can be justified by the reduced steam flow through the turbine.

Another option to replacing a steam turbine that drives a fan or horizontally split case pump is extending the shaft on both ends of the driven equipment and having a motor driver and a steam turbine installed on opposite ends of the driven equipment. Either the motor or the turbine can easily be selected as the main driver by increasing or decreasing the speed of the steam turbine above or below the synchronous speed of the motor.

Vary header pressures Varying steam header pressures can affect the steam rate through turbines. To lower turbine steam rates, either the inlet steam pressure can be increased or the exhaust pressure decreased. Lowering exhaust pressure will

have more impact on turbine steam rates than raising the inlet pressure. The same technique can be used to obtain more horsepower from a steam turbine that has a fully open governor valve. Varying steam header pressures can also help transport steam between battery limits, which can help eliminate excess steam conditions.

Optimize deaerator operation If it is not possible to eliminate excess low-pressure steam, then effectively utilizing the steam is the next best alternative. Your boiler area's deaerator offers a low-cost opportunity to recover excess low-pressure steam. If your deaerator is rated for a much higher pressure than it is operating, the deaerator pressure can be increased to absorb more steam. The resulting hotter boiler feed water reduces the amount of fuel required in the boilers and increases the amount of steam generated in waste heat boilers.

Eliminate Steam Deficits

If steam is constantly being let down to meet the demands of the low-pressure steam header, then steam header demands should be reduced. Condensate and steam leaks should be repaired soon after they are detected because they can grow significantly larger in a very short time. If the leak cannot be isolated, several companies specialize in stopping steam leaks. Also, to reduce steam deficits:

Test traps The plant's steam trap testing and repair program should be reviewed to determine its effectiveness. Ask:

- How frequently are steam traps tested?
- What is the method of testing?
- What is the steam trap failure rate?
- What method is used to repair or replace the steam traps?
- How long does it take after the faulty trap has been detected before it is replaced?

Standardizing on a specific trap that functions well in your plant, maintaining a good steam trap testing program, and repairing faulty steam traps soon after they are identified will minimize your steam trap energy costs.

Use correct amount of steam Using the correct amount of steam for the required duty of equipment can significantly reduce steam use. Using the plant steam balance and plant design information, compare actual versus plant design steam use for all major steam users. Large discrepancies in steam use that cannot be accounted for by changes in plant operation suggest savings opportunities.

Most plants can control steam flow with a flare steam control monitor. This monitor uses an infrared detector to determine the amount of smoking at the flare tip and adjusts the steam flow to the flare to eliminate the smoking. Flare steam control monitors can usually be economically justified.

Insulate Proper insulation of piping and equipment should never be overlooked to reduce the steam demand. Often flanges, control valves, steam turbines, man ways, sections of piping, heads on vessels, etc. are uninsulated. If steam is in demand at the steam pressure level of the uninsulated piping and equipment, the piping and equipment should be insulated. Conduct a survey of the condensate and steam system. Also conduct a study of all insulated high-temperature piping that has been in service for numerous years. It may be economically justifiable to repair damaged insulation or to add an additional layer of insulation.

Recover Waste Heat

If all of your steam users are efficiently using steam, then waste heat recovery opportunities need to be explored. Compare the duties and temperature profiles on services cooled by air or water to services heated by steam. If the profiles compare favorably, consider projects to recover waste heat energy.

One excellent heat sink for waste heat recovery is deaerator make-up water. When the deaerator make-up water is preheated, the deaerator's steam demand will be reduced.

If, after reducing the demand on all steam users and implementing all economically attractive waste heat recovery projects, steam is still being let down to meet the demands of a low-pressure steam header, consider installing steam turbine drivers to

(continued on page 4)

Steam System Optimization

continued from page 5

replace electric motor drivers. Again, steam turbine efficiency needs to be a prime concern.

Add Flexibility

Steam systems are dynamic. Changes in the process can change the amount of steam that is venting to the atmosphere and being let down between pressure levels. Consider the following to add flexibility to your steam system:

- Identify steam turbines and motor drivers that can be started up or shut down to minimize steam vents and let down flows.
- Adjust steam header pressures to allow steam to be transported to other locations or to reduce the steam flow through turbines.
- Vary deaerator pressure slowly to eliminate steam venting but avoid excessive steam being let down.

Optimize Steam Boilers

Repairing steam leaks and insulating equipment is also important at your steam boilers. Since boiler steam pressure and temperature levels are the highest in the plant, these measures will pay out quickly.

Also, repair air leaks around boilers. On negative draft boilers, air leaks waste fuel and cause refractory damage and erroneous excess oxygen readings. On positive draft boilers, air leaks waste fuel and can cause personal injury. Some fan and boiler capacity is also lost with air leaks.

Repair of damaged refractory can save energy because hot spots on the outer shell of the boiler result in heat loss to the atmosphere and reduced boiler efficiency. Refractory damage can also lead to mechanical damage to the boiler and possible personal injury.

Boilers need to be excess oxygen controlled. Oxygen analyzers should be calibrated and the fuel/air ratio controller tuned. Control boiler excess oxygen levels at the boiler manufacturer's recommendations.

Contact Bob Aegerter at (815) 942-7390; e-mail to Robert.Aegerter@Equistarchem.com.

Boiler Efficiency vs. Steam Quality: The Challenge of Creating Quality Steam Using Existing Boiler Efficiencies

By Glenn Hahn, Technology Manager,
Spirax Sarco, Inc., Allentown, PA

This article is condensed from a technical paper/video presentation at the 1998 Industrial Energy Technology Conference Steam Session. For the full paper, call (800) 862-2086.

A boiler works under pressure, and it is not possible to see what is happening inside of it. The terms "wet steam" and "carry over" are every day idioms in the steam industry, yet very few people have ever seen these phenomena, and the actual water movement inside a boiler has remained highly speculative. This article illustrates the effects of steam quality vs. boiling efficiency during different boiler and steam system demands. The four different operating situations described below can affect steam quality.

Case 1: On/Off Boiler Feed

Simply stated, boilers operate using a hot heat transfer surface covered with water. Steam bubbles produced at the transfer surface rise through the water and enter the steam system. Higher pressure at the heat transfer surface than at the water's surface causes steam bubbles to either a) leave the boiler slightly superheated, or b) cool to the saturation temperature of the water as they rise through the water. Under normal conditions, the steam bubbles tend to cool to saturation temperature as they rise through the water.

Feed water enters the boiler between the heat transfer surface and the surface of the boiling water. Although preheated, the feed water is still colder than the water in the boiler, creating a cold layer within the boiler water. Steam bubbles rise through this cold layer; they cool and some of the steam condenses. This causes two serious problems.

First, steam bubbles leave the water's surface and enter the steam system containing water mist. If a large amount of feed water enters the boiler, the steam space above the water level becomes foggy. This fog and the low-quality steam



Steam quality is affected by water movement during different boiler operating situations.

that results continue until the water in the boiler becomes reasonably isothermal.

Second, this large amount of cooler water slows the rate of steam production until the water reaches saturation temperature.

These problems are preventable by using continuous boiler feed rather than on/off boiler feed. A modulating feed adds water at a very low rate, which keeps the boiler water relatively isothermal and prevents clouding.

Case 2: Reduced Operating Pressure

"Operate the boiler at its maximum design pressure," say the boiler designers. Too often, this rule is not followed when energy cost reductions are needed. During low steam demand, or when all the use points require pressure reduction stations, boilers are often operated at substantially less than design pressure. While, in some boilers, operation at lower pressure can slightly increase energy efficiency, it also reduces steam quality.

Lower Pressure Increases Entrainment

Water entrainment occurs as steam bubbles break through the final water layer into

(continued on page 5)

continued from page 4

the steam space. The bubble's initial burst produces a rush of high-velocity steam that carries a small amount of water into the steam space. Additionally, the loss of the steam bubble from the water surface creates a crater and splashing, and water droplets are easily entrained in the rising steam.

Low-pressure operation requires a larger volume of steam to carry heat energy. This produces more and larger steam bubbles, which creates greater turbulence on the water surface. Higher vapor velocity from low-pressure operation combined with the turbulence tends to carry water droplets into the steam system.

The solution is to operate the boiler at its maximum design pressure and use pressure-reducing valves where required.

Case 3: Rapidly Fluctuating Demand

In most industrial steam systems, steam demand fluctuates widely and can seriously affect steam quality. A rapid, short-term steam demand increase of only 15% can cause high entrainment of water in the boiler. Such demand increases occur quite frequently in industrial plants when steam valves are opened all at once.

When a steam valve opens, two problems occur in the boiler. First, steam pressure drops rapidly and causes entrainment. Second, the interface between water and steam rises. A phenomenon known as "swell" results as the water level rises and is sucked into the steam line. This boiler water loss can shut down the boiler; in the meantime, the steam lines fill with water.

Compact Boilers Can Magnify the Problem

Modern boilers are highly efficient and very compact. While this design has advantages, these boilers have little steam space to dampen changes in steam demand. If steam use increases only slightly, the pressure in the boiler can drop significantly, increasing entrainment.

High Entrainment Fools Low Water-Level Alarm

Sometimes, steam demand increases are so disruptive that the boiler life and steam quality suffers. The external indicator might show a satisfactory water level; yet the actual level of the water/steam mixture

in the boiler may be filling the steam space, and water may be pouring into the steam lines. Tubes can overheat and can be damaged by the time the external detector identifies a low water level and shuts down the boiler. The plant will be without steam until the boiler is restarted.

The key to reducing this cause of poor steam quality is to prevent rapid increases in steam demand. Modern computerized control systems using a PLC or DCS can accommodate this solution.

Case 4: High TDS

High or fluctuating total dissolved solids (TDS) in boiler water increases tube corrosion and/or fouling. The table below shows examples of additional operating costs that can result from poor quality feed water. TDS results in low heat transfer, reduced boiler capacity and efficiency, and shortened tube life. It can also affect steam quality.

Increased TDS in the boiler water increases foam production on the water's surface. This foam is produced by, and is easily entrained by, the steam rising out of the water. It can be drawn into the steam system, depleting the boiler of water before the level detector can identify the problem while filling the steam lines with corrosive water.

The solution is to keep TDS at least as low as that recommended by the boiler manufacturer. There is no definitive evidence indicating a steam quality difference between on/off or modulating blowdown to control TDS. However, given the adverse effect of rapid and intermittent inflows of make-up water, modulated blowdown is preferred.

Conclusion

Steam quality—a measurement of the amount of water entrained in the steam—depends not on the efficiency of the boiler but on the ability of the steam to separate from boiling water, without carrying liquid water particles over the range of boiler operations. To prevent poor quality steam:

- A. Control steam usage to ensure that steam demand does not exceed boiler capacity.
- B. Control steam usage change to ensure rapid changes in steam demand will not reduce steam quality.
- C. To affect A and B above, use modulating instead of on/off valves at steam use points.
- D. Add boiler feed water with modulating, not on/off, controls.
- E. Use TDS controls rather than time-based blowdown.
- F. Operate the boiler near its maximum design pressure.

When these recommendations are not followed, reductions in steam quality can be dramatic. Low steam quality can damage steam distribution equipment, control valves, and heat exchangers by water hammer, erosion, and corrosion. This results in shortened equipment service life, steam loss, low operating efficiency, and even safety problems.

Contact Glenn Hahn at (800) 624-1817 x2099 with questions or for information about the video that accompanies this paper.

ADDITIONAL OPERATING COSTS FROM POOR-QUALITY FEED WATER

Steam flow 100,000 lb/hr and feed water temperature 230°F in all cases.

	Steam Temperature: Saturated/ Steam Pressure: 300 psig		Steam Temperature: 850°F/ Steam Pressure: 850 psig	
Blowdown, %	2	10	2	10
Boiler duty, MM Btu/hr	100.8	102.4	123.1	125.7
Heat input, MM Btu/hr	121.5	123.4	148.4	151.5
Flash steam recovery, %	20		33	
Additional cost per year	–	\$36,840	–	\$49,850

Same efficiency of 83% HHV assumed in all cases.

Source: V. Ganapathy, "Examining the Costs of Boiler Operation," *Chemical Online*.

Steam System Improvement: A Case Study

By Ven V. Venkatesan, Director of Engineering Services and Novi Leigh, Steam Systems Engineer, Armstrong Service, Inc., Orlando, Florida

This article summarizes a case study presented at the 1998 Industrial Energy Technology Conference Steam Session. For the full paper, call (800) 860-2086.

Steam plays a pivotal role in industrial plants because of its availability and advantageous properties for use in heating processes and power cycles. Therefore, it is widely used as a heating medium. Steam systems consist of components such as the steam generator (boiler), steam distribution lines, process heating equipment, steam turbines, pressure reducing valves, condensate return lines, and steam traps.

A thorough review of a major petroleum refinery system confirmed energy savings potential in its boiler, steam distribution, and condensate systems. This article highlights eight energy-saving opportunities identified at the site, and the measures taken to realize these savings.

Replace All Defective Steam Traps

Steam traps remove condensate from the steam distribution system. They also remove air and other non-condensable gases that cause corrosion and impede heat transfer. Misapplication, improper sizing, and piping conditions are the common causes of failed steam traps.

Selection of steam traps depends on the conditions of the system handled, such as condensate load, back pressure, air and non-condensable gas content, and process application like constant pressure or modulating. The wrong steam trap in an application can be as disastrous as a failed steam trap in an open or closed position; both errors lead to energy waste. Undersized steam traps will not remove condensate, which causes flooding of the equipment and can produce damaging water hammer. Oversized traps may result in wasted live steam.

Steam trap applications can be divided into three categories: 1) line drip service, 2) tracer service, and 3) process service. There are over 3,000 steam traps at the site. Most of them are for drip and tracer application, with a small portion for coils and heat exchangers. At this site, 60% of the steam

traps are in service, and 23% of those were found defective in blow-through, cold-plugged, or leakage. A diligent maintenance process is required to capture and sustain savings from steam traps.

Optimize Combustion in Boilers

Optimum boiler combustion occurs when excess air is supplied at the correct amount so that fuel is completely burned and flue gas heat loss is minimized. Optimum excess air depends on the type of fuel and burner design. In this plant, combustion air is supplied either from a forced draft (FD) fan or by the hot exhaust gases from a gas turbine. Analysis of operating data shows the boilers operate at 30% to 35% excess air levels. In general, gas burners are designed for excess air levels between 5% and 10%.

An eight-step action plan was recommended to optimize excess air levels at the boilers:

1. Stabilize boiler at its normal operating load.
2. Verify present combustion conditions with a portable flue gas analyzer.
3. If combustibles and CO are not present, reduce FD air in smaller steps.
4. Verify combustion conditions again after 10 minutes of stable boiler condition.
5. If combustibles are not present, repeat steps 3 and 4 until oxygen level in the stack gas reaches around 2% to 3%.
6. Reset the oxygen trimming system in the fuel-air ratio controller of the boiler in conjunction with the combustibles/CO analyzer.
7. Repeat steps for other boilers.
8. Nominate utility operating personnel to Efficient Boiler Operation seminars.

A decision was also made to install a new combustibles analyzer and hook up oxygen trimming with the existing fuel-air ratio controller.

Eliminate Back Pressure in Condensate Line to Enhance Condensate Recovery

Collection and return of clean condensate streams and utilization of available heat are practical and economical energy



Review of a refinery's boiler, steam distribution, and condensate systems revealed potential energy savings of \$1 million+.

conservation opportunities. Benefits include reductions in make-up water and water treatment costs, boiler blowdown resulting in direct fuel savings, steam requirement for boiler feed water deaeration, raw water costs, and sewage discharge costs.

The overall condensate recovery at the site is between 55% and 60% of steam generation. High back pressure in the return line causes condensate from steam traps to drain into the atmosphere at some locations. A major reason for this is steam passing through failed traps. Insufficient sizing and orientation of condensate return lines also contribute to back pressure.

Back pressure in the return header should be corrected to enhance condensate recovery. Enhancing condensate recovery involves additional time and effort. Nonetheless, this could potentially improve condensate recovery to over 80%.

Install Low-pressure Economizer

The largest energy loss in every combustion process is flue gas heat. Reducing flue gas temperature improves boiler efficiency. As a rule, every 40°F reduction in stack temperature increases boiler efficiency by 1%. Installing waste heat recovery equipment in a natural gas-fired boiler can improve its efficiency when the stack temperature exceeds 250°F. The limiting factor to flue gas heat recovery is corrosion if oxides of sulfur condense as flue gas cools. This occurs only when the fuel contains sulfur.

(continued on page 7)

continued from page 6

An economizer can recover the heat from flue gas to preheat the boiler feed water. Generally, every 11°F temperature rise in the feed water increases boiler efficiency by 1%.

The utility boilers at the site are designed with economizers. Boilers are gas-fired with little or no sulfur content in the fuel. Combustion air is supplied from gas turbine exhausts, and flue gas exits the boilers at approximately 310°F-320°F. Flue gas cannot be cooled below 310°F because boiler feed water temperature at the deaerators is maintained between 275°F-285°F. This restricts heat recovery despite firing with low-sulfur fuel.

Installing a low-pressure economizer in the boiler flue gas duct would connect the existing economizer and chimney. The flue gas temperature would be 230°F. This method of heat recovery is a proven practice at many sites.

Install Vent Condensers

Boiler feed water must be free of air and other dissolved gases that harm boiler tubes. Gases are removed in the deaerator where water is sprayed and scrubbed with steam. Steam and the non-condensable gases are vented from the deaerator. However, this steam contains a lot of recoverable heat.

At this plant, steam is vented in excess of the normal levels at deaerators and some condensate receiving tanks. Deaerator pressure is normally maintained at 7–10 psig because at pressures above 7 psig, the escaping vapors will be mostly steam.

A vent condenser installed at the top of the deaerator can capture part of the heat from the escaping steam, while allowing

the non-condensable gases to escape. The recovered heat can be used for heating the boiler feed water in the vent condenser. The proposed condenser would be cooled by incoming, fresh demineralized water before entering the deaerator.

Supply Low-pressure Steam Instead of Medium-pressure Steam to Jetty Services

Steam in the plant's Jetty area is used for space heating, tracing, and line purging. Steam is supplied at 65 psig by letting down through a pressure-reducing valve (PRV) from the 225-psig, medium-pressure steam header. Steam users at the Jetty area are not critical and can tolerate marginal variations in steam pressure. Often, low-pressure steam is in excess and is rejected to atmosphere.

A jump-over connection could be made from the low-pressure steam header to the medium-pressure steam line leading to Jetty services. This would also keep the PRV bypassed or removed. The medium-pressure steam line at the upstream of the jump-over connection should be isolated, preferably with a spaded valve.

Implementing this recommendation will reduce this plant's energy loss from low-pressure steam condensing and will avoid letting down steam from medium to intermediate pressure.

Automatic Switch-over between Motor and Steam Turbine Drives

At this site, steam turbine exhaust cannot meet the demand of medium-pressure steam that requires steam let down from higher to lower pressure through a PRV.

Most of the plant's rotating equipment has turbine drives to supply low-pressure steam and motor drives for operating flexibility. This flexibility optimizes costs by uti-

lizing the steam's pressure energy to drive the compressors, pumps, and blowers. Pressure-reducing valves between the three pressure levels meet the demand of lower-pressure steam. Excess low-pressure steam is condensed to avoid steam venting and to save feed water. The steam condensing operation and letting down steam from higher to lower pressure are inefficient operations of the system.

Recommendations to minimize steam flow through pressure reducing valves and condensing of excess steam include:

- Listing all steam turbine driven equipment with present steam consumption rate at normal operating conditions.
- Measuring electricity consumption in the same equipment when driven by electric motor.
- Preparing a priority list for switch-over.
- Developing software that can combine the on-line DCS data and priority list to advise the utility operator for switch-over based on PRV steam flows and excess low-pressure steam at specified steam and electricity cost.

A systematic switch-over between turbine and motor drives will reduce steam flows through PRVs and excess condensing steam and could result in an 80% reduction in PRV steam flow.

Fix All Identified Steam Leaks

Steam leaks contribute to direct heat loss in the steam distribution system and are the most obvious to fix immediately. Steam leaks increase boiler load and make-up water consumption. A survey identified all steam leaks and categorized them as leaks to be fixed offline or online.

Conclusion

This refinery could save \$1,110,000 in annual steam costs by implementing the eight recommendations. The table at left summarizes the recommendations. The measures require no major process modification. Some require no investment and can be implemented through better day-to-day operation or a periodic maintenance program. Those that require new equipment can be done during the plant turnaround. Optimizing the steam system will also reduce carbon emission by 5 million pounds annually.

Contact the authors at (407) 370-3301; e-mail at VeeVen@aol.com or NLeigh6200@aol.com.

STEAM SYSTEM SAVINGS RECOMMENDATIONS		
Recommendations	Estimated Savings (\$/year)	Payback (Approximate)
1. Replace all identified defective steam traps.	284,600	19 months
2. Optimize combustion in boilers.	94,500	10 months
3. Enhance condensate recovery by eliminating sources of backpressure in condensate return.	105,900	14 months
4. Install low pressure economizer in boiler flue gas ducts.	166,000	24 months
5. Install vent condenser for deaerator.	43,200	19 months
6. Supply LP steam instead of MP steam to Jetty service.	41,100	6 months
7. Optimize steam balance by systematic switch-over between motor and steam turbine drives.	28,200	12 months
8. Fix all identified steam leaks.	346,500	3 months
Total estimated savings	1,110,000	12.6 months
Estimated annual steam cost	\$8.6 million	
Reduction in steam cost by implementing all recommendations	12.90%	
Reduction in environment emission of Total Carbon	5 million lbs/year	

3E Plus™ Saving Money through Improved Industrial Insulation

An interview with Bill Brayman, Technical Chairman, Commercial/Industrial Insulation Committee, North American Insulation Manufacturers Association (NAIMA), Alexandria, Virginia

Please describe your role at NAIMA?

I am the technical chairman of the committee on commercial/industrial insulation. The committee is charged with supplying technical back up for the insulation industry and members of NAIMA.

Why did you become involved in DOE's Steam Challenge?

The insulation industry recognized that a problem existed with people not being able to identify Btu loss in steam lines, insulated or not. Nobody could count it. So, we joined the Steam Challenge to help disseminate conservation materials/tools on steam piping to help industry save money and energy. Through our involvement, we hope to equip people with the ability to translate the performance of their insulation into dollars—that is what gets everybody's attention.

You mentioned conservation tools. Can you give an example of one?

There is a software tool called 3E Plus™ that provides industry with the performance, Btu saving, and payback data needed to determine the most appropriate insulation thickness for a company's application. It was built with academia and DOE. In a typical plant, an employee has no idea what dollars are radiating off the pipes. 3E Plus™ helps users understand this loss in Btus, dollars, and greenhouse gas emissions. Version 2.12, the one that is available now, is a DOS program and can not be used on a network. To better address the needs of the industry, we are developing a new version C3.0.

Can you explain how the soon-to-be-released upgraded version of 3E Plus™ will differ from the current 2.12 version?

The new version:

- takes into account metrification of the construction industry—a high-priority issue with the users.

- addresses different terminology for pipes. The new program will correlate the European names with the American ones.
- gives the cost difference and savings to run one foot of uninsulated pipe versus insulated pipe, after inputting fuel cost, fuel type, and annual operating hours of the pipe. It will also show the reduction in CO₂, NO_x and CE (carbon equivalency) for an insulated versus uninsulated pipe, which was

not possible with version 2.12. The previous version just showed the Btu cost of running uninsulated pipes.

- addresses different types of pipes, such as stainless steel and copper.
- runs on Windows 95 and Windows NT.

Is 3E Plus™ difficult to use?

No, one just needs to fill in the blanks. What makes it very user friendly is the defaults that are programmed into the software. If a user does not have the answer to one of the questions, he or she can go with the default data or use the help comments at the bottom of the screen.

Can you give an example of companies successfully using 3E Plus™?

Georgia-Pacific and Bethlehem Steel's Burns Harbor division have both benefitted from the use of 3E Plus™. In the interest of time, I will just go into the Burns Harbor example. They were awarded the National Insulation Association's 1998 Industrial Energy Savings Award for outstanding energy conservation efforts, one of which involved thermal insulation. The award was presented at DOE's energy efficiency symposium and exposition in Washington, D.C.

What exactly did they do?

They covered 1,040 feet of a 14-inch pipe with 3.5 inches of calcium silicate pipe insulation and aluminum jacket. The heat loss for the pipe was 5,660 Btus per foot per hour. After adding the insulation, the Btus were reduced by 95.5%. Now



William Pitkin (L), Executive VP of the National Insulation Association (NIA) presents the NIA 1998 Industrial Energy Savings Award to Robert Chango (R), VP Operations at Bethlehem Steel, Burns Harbor. Also present, Denise Swink, Deputy Assistant Secretary, DOE's Office of Industrial Technologies.

they are losing only 253 Btus per foot per hour from the pipe.

Burns Harbor would have spent \$353 a year per foot of pipe to operate with no insulation on a steam pipe. They saved, by use of insulation, \$337.50 per foot per year. The insulated 1,040 feet of the 14-inch pipe is also saving 6,617 lbs of CO₂ per foot per year, 1,805 lbs of CE per foot per year, and 14.2 lbs of NO_x per foot per year. For the entire distribution piping in the plant, Burns Harbor is saving over 2.65 trillion Btus annually through insulation!

Why did they decide to do this?

They have an active energy conservation program and were knowledgeable of the heat loss on the uninsulated pipe. So, using insulation was really a no-brainer. We, meaning NAIMA, inventoried the pipes and quantified, using 3E Plus™, how much was being saved. Bethlehem Steel knew they were saving money and energy, but didn't know how much. The software program confirmed what Bethlehem Steel was thinking in terms of the savings. The payback works out to less than 6 months.

When will the new version be released?

Version 3.0 will be available later this summer. People can access a copy of 3E Plus™ through the Web site at www.oit.doe.gov/tools.shtml#software. Otherwise, people can call (800) 862-2086 for information on how to obtain a copy.