



Building America Case Study

Advanced Boiler Load Monitoring Controllers

Chicago, Illinois

PROJECT INFORMATION

Project Name: Field Test of Boiler Primary Loop Temperature Controller

Location: Chicago, IL

Partners:

Partnership for Advanced Residential Retrofit (PARR),
gastechology.org/PARR

Greffen Systems, greffensys.com

Building Component: HVAC

Application: New or retrofit; multifamily

Year Tested: 2013–2014

Applicable Climate Zones: Cold, Very Cold, Mixed-Humid

PERFORMANCE DATA

Cost of energy efficiency measure (including labor): \$7,700

Projected energy savings: Up to 14% heating savings

Projected energy cost savings: \$1600–\$2000/year

Most of Chicago's older multifamily housing stock is heated by centrally metered steam or hydronic systems. The cost of heat is typically absorbed into the owner's operating cost and is then passed to tenants. Central boilers typically have long service lifetimes; the incentive for retrofit system efficiency upgrades is greater than equipment replacement for the efficiency-minded owner. System improvements as the "low-hanging fruit" are familiar, from improved pipe insulation to aftermarket controls such as outdoor temperature reset (OTR) or lead/lag controllers for sites with multiple boilers.

The U.S. Department of Energy's Building America team Partnership for Advanced Residential Retrofit (PARR) installed and monitored an advanced load monitoring (ALM) aftermarket controller, the M2G from Greffen Systems, at two Chicago area multifamily buildings that claim 10% to 30% fuel savings over a heating season. Both buildings, one in Chicago and one in the suburb of Cary, Illinois, have OTR controls. The M2Gs:

- Are compatible with hydronic boilers only.
- Monitor loads and continuously measure supply and (in some cases) return water temperatures.
- Derive energy savings by dynamically managing the boiler differential, where a microprocessor with memory of past boiler cycles prevents the boiler from firing for a period of time, to limit cycling losses during perceived low-load conditions.
- Differ from OTR controllers, which vary boiler set points with ambient conditions while maintaining a fixed differential.

Results show that energy savings depend on:

- How much boilers are oversized for their load (cycling rates)
- Time of year (savings vary with cycling rates and greater savings are observed in shoulder months).

Over the monitoring period, oversized boilers at one site showed reductions in cycling and energy consumption in line with previous laboratory studies; less oversized boilers at another site showed muted savings.

Description

ALM controllers are used primarily in large commercial and industrial settings; however, low-rise multifamily retrofits may also achieve savings. Residential hot water boilers are typically operated with wider boiler differentials than commercial or industrial boilers (20°F versus 10°F or less); thus, there are fewer opportunities for reductions in cycling losses by dynamic widening of this differential.



An ALM controller can be installed in 2 hours or less per boiler. Temperature sensors are installed external to hot water piping and limited labor is required to splice into the thermostat wiring.



These ALM controllers do not require calibration. They infer boiler temperature settings and are compatible with OTR systems.

For more information, see the Building America report, *Field Test of Boiler Primary Loop Temperature Controller*, at: buildingamerica.gov

Image credit: All images were created by the PARR team.

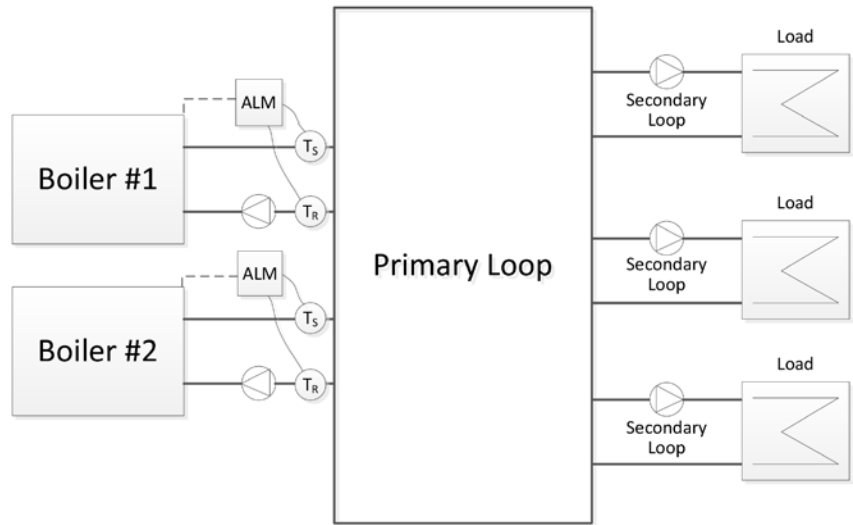

The ALM controller works with hydronic heating systems with “primary/secondary” piping arrangements (see figure) by monitoring primary loop temperatures. When the boiler aquastat calls for heat, the ALM controller may delay this firing by up to 15 minutes depending on temperature data. The ALM controller does not activate a standby boiler, nor does it stop a firing boiler. Rather, it limits cycling losses by selectively lengthening firing cycles. Savings are proportional to the boiler’s oversizing. Features that reduce the energy savings potential include multistage/modulating combustion and existing OTR. Features such as envelope and pipe insulation improvements increase the savings potential. At this time, ALM controllers are not compatible with central steam boilers, because they monitor pipe surface temperatures only.

Lessons Learned

- One building had oversized boilers cycling at least 100 times per day. Cycling decreased by 32% and therm savings of 14% occurred during shoulder months (weather adjusted).
- The other building had 50 or fewer cycles per day. Cycling decreased by 17% with 7% therm savings during shoulder months.
- In widening differentials, heating temperatures can be lower than designed. No tenants complained about temperature during the monitoring period.
- Both sites have OTR controllers. The ALM controllers operated successfully in parallel, but showed fewer benefits.

Looking Ahead

Because energy savings from ALM controllers are site dependent, their prediction requires advanced knowledge of the boiler system, such as typical cycling rates, oversize/utilization factors, and temperature differential settings. This first field study of its kind, complementary to a laboratory study performed by PARR member Gas Technology Institute (GTI), can help utilities identify ways to reliably predict energy savings for prescriptive measures, something GTI is currently working with utilities in the Chicagoland area to do.