



Comparison of Vehicle Efficiency Technology Attributes and Synergy Estimates

G. Duleep
ICF Incorporated, LLC.
Fairfax, Virginia

NREL is a national laboratory of the U.S. Department of Energy, Office of Energy Efficiency & Renewable Energy, operated by the Alliance for Sustainable Energy, LLC.

Subcontract Report
NREL/SR-6A20-47806
February 2011

Contract No. DE-AC36-08GO28308

Comparison of Vehicle Efficiency Technology Attributes and Synergy Estimates

G. Duleep
ICF Incorporated, LLC.
Fairfax, Virginia

NREL Technical Monitor: Caley Johnson
Prepared under Subcontract No. KACX-8-88312-00

NREL is a national laboratory of the U.S. Department of Energy, Office of Energy Efficiency & Renewable Energy, operated by the Alliance for Sustainable Energy, LLC.

This publication received minimal editorial review at NREL.

NOTICE

This report was prepared as an account of work sponsored by an agency of the United States government. Neither the United States government nor any agency thereof, nor any of their employees, makes any warranty, express or implied, or assumes any legal liability or responsibility for the accuracy, completeness, or usefulness of any information, apparatus, product, or process disclosed, or represents that its use would not infringe privately owned rights. Reference herein to any specific commercial product, process, or service by trade name, trademark, manufacturer, or otherwise does not necessarily constitute or imply its endorsement, recommendation, or favoring by the United States government or any agency thereof. The views and opinions of authors expressed herein do not necessarily state or reflect those of the United States government or any agency thereof.

Available electronically at <http://www.osti.gov/bridge>

Available for a processing fee to U.S. Department of Energy and its contractors, in paper, from:

U.S. Department of Energy
Office of Scientific and Technical Information

P.O. Box 62
Oak Ridge, TN 37831-0062
phone: 865.576.8401
fax: 865.576.5728
email: <mailto:reports@adonis.osti.gov>

Available for sale to the public, in paper, from:

U.S. Department of Commerce
National Technical Information Service
5285 Port Royal Road
Springfield, VA 22161
phone: 800.553.6847
fax: 703.605.6900
email: orders@ntis.fedworld.gov
online ordering: <http://www.ntis.gov/help/ordermethods.aspx>

Cover Photos: (left to right) PIX 16416, PIX 17423, PIX 16560, PIX 17613, PIX 17436, PIX 17721



Printed on paper containing at least 50% wastepaper, including 10% post consumer waste.

1.0 Introduction

Analyzing the future fuel economy of light-duty vehicles (LDVs) requires detailed knowledge of the vehicle technologies available to improve LDV fuel economy. The National Highway Transportation Safety Administration (NHTSA) has been relying on technology data from a 2001 National Academy of Sciences (NAS) study (NAS 2001) on corporate average fuel economy (CAFE) standards, but the technology parameters were updated in the new proposed rulemaking (EPA and NHTSA 2009) to set CAFE and greenhouse gas standards for the 2011 to 2016 period. The update is based largely on an Environmental Protection Agency (EPA) analysis of technology attributes augmented by NHTSA data and contractor staff assessments. These technology cost and performance data were documented in the Draft Joint Technical Support Document (TSD) issued by EPA and NHTSA in September 2009 (EPA/NHTSA 2009).

For these tasks, the Energy and Environmental Analysis (EEA) division of ICF International (ICF) examined each technology and technology package in the Draft TSD and assessed their costs and performance potential based on U.S. Department of Energy (DOE) program assessments. ICF also assessed the technologies' other relevant attributes based on data from actual production vehicles and from recently published technical articles in engineering journals. ICF examined technology synergy issues through an ICF in-house model that uses a discrete parameter approach.

The review of the technology attribute data in the TSD and in the regulatory impact analysis (RIA) showed that the attribute data are, in most cases, consistent with data developed by ICF, and that some of the differences in retail price equivalent (RPE) in those data are attributable to differences between the markup for retail price used in the TSD and that used by ICF. Tables 1-1 through 1-4 show the comparisons of the ICF data with those published in the TSD. The ICF data are based on a comprehensive review of estimates published by manufacturers and suppliers to the industry. In a few areas of concern, we believe the TSD data are inconsistent with most other analyses of attributes or internally inconsistent with the TSD analysis of other comparable technology. This report first comments on technology RPE in the TSD and then on the fuel economy benefit for each technology.

Table 1-1. Spark Ignition Engine Technologies

Technology	RPE (\$)		Fuel Consumption Reduction (%)	
	EEA 2008 V6 ^a	EPA/NHTSA 2009 ^b	EEA 2008 V6 ^a	EPA/NHTSA 2009 ^b
DOHC ^c Variable Valve Timing (Intake)	104	80	1.5	1
Variable Valve Timing (Intake + Exhaust) SOHC ^d	104	80	1.6	2
Variable Valve Timing (Dual) DOHC	184	157	2.2	2
Variable Valve Lift and Timing— Intake Continuous (DOHC)— Constant Displacement	460	449	7.4	4
Cylinder Deactivation with Noise Control	310	150 (noise control?)	6.1	6
Camless Valve Actuation— Constant Displacement	900	501	13	5–15
Stoichiometric Gasoline Direct Injection (SGDI)	230	287	3.4	2–3 (page 3-29)
Turbocharging with Engine Downsized (no credit)	500	329	6.5	5–7
Turbocharging with Gas Direct Injection (GDI) and Engine Downsizing	220 (V6 to I4)	490 (est.)	13.0	12–14 (uncertain)
Improved Lubricating Oil	20	3	1.0	0.5
Engine Friction Reduction III	65	75	1.5	1–3

^a EEA baseline is a port fuel injected (PFI), four-valve, fixed-valve V6 engine with a compression ratio (CR) of 9.5. Unless otherwise noted, the numbers are at constant performance.

^b The EPA baseline vehicle is defined as one with fixed timing, four valves per cylinder, PFI, and a four-speed automatic transmission, unless specifically noted. Minivan class is used because all minivans use V6 engines.

^c DOHC stands for double overhead cam

^d SOHC stands for single overhead cam

Table 1-2. Body and Accessory Technologies

Technology	RPE (\$)		Fuel Consumption Reduction (%)	
	EEA 2008	EPA/NHTSA 2009	EEA 2008	EPA/NHTSA 2009
Weight Reduction by 5%	1.00/lb	1.48/lb (page 3-73)	3.1	3–4
Rolling Resistance Reduction by 10%	20	6	1.5	1–2
Drag Reduction by 20%	70	42	3.8	3
Alternator Improvements	17	76	0.5	1–2
Electric Accessories	50 (water pump)		0.5	
Electric Power Steering	80	94	2.0	2

Table 1-3. Transmission Technologies^a

Technology	RPE (\$)		Fuel Consumption Reduction (%)	
	EEA 2008	EPA/NHTSA 2009	EEA 2008	EPA/NHTSA 2009
Five-Speed Automatic Transmissions	200	90	2.4	2.5
Six-Speed Automatic Transmissions	220	150	4.3	4.5–6.5
Automated Manual Transmissions (six-speed, wet clutch)	240	289	6.5	9.5
Continuously Variable Transmissions	380	224	5.7	6
Early Torque Converter Lockup	5	25	0.5	0.5
Aggressive Shift Logic	30	28	1.5	1–2

^aAll numbers compared to four-speed automatic, unless otherwise noted.

Table 1-4. Hybrid and Diesel Technologies

Technology	RPE (\$)		Fuel Consumption Reduction (%)	
	EEA 2008 ^a	EPA/NHTSA 2009	EEA 2008 ^a	EPA/NHTSA 2009
Stop-Start 12V	250	118 (page 3-30)	3.8	2-2.5 (page 3-30)
Belt Alternator Starter (BAS) Hybrid	600	351 (small car, 42V)	10	7.5 (small car, stop-start 42V)
Integrated Motor Assist (IMA) Hybrid	2,500	2,854 (small car, w/ engine downsize)	25	30 (small car, w/ engine downsize)
Two-Motor Hybrid	3,800	3,967 (small car, power split)	33	35 (small car, power split)
Diesel I4	2,700	2,164	25	19
Diesel V6	3,800	2,961 (Table 3-10, SCR based)	27	25 (page 3-37)

^a For hybrids, EEA RPE estimates are for hybrid components only, and fuel consumption reduction is for system level and includes engine downsizing credits. For the diesel, the value range represents engine cylinder count from I4 to V6. The diesel RPE includes after-treatment cost. All RPE numbers reflect 2015 timeframe scale and learning-based cost reduction.

Figures from:

- ICF-EEA, “Advanced Technologies to Improve Fuel Economy of Light Duty Vehicles.” Fuel consumption figures derived from fuel economy. (ICF-EEA 2007)
- The U.S. EPA and NHTSA, “Draft Joint Technical Support Document, Proposed Rulemaking to Establish Light-Duty Vehicle Greenhouse Gas Emission Standards and Corporate Average Fuel Economy Standards,” September 2009 (EPA/NHTSA 2009).
- EPA’s figures are used for comparison. EEA RPE values are compared against Table 3-25 through 3-29 values, the Incremental Piece Costs for Technologies Marked-up to Include both Direct and Indirect Costs in 2016 (2007\$). EPA’s technology effectiveness is expressed as absolute CO₂% reduction from baseline vehicle in Tables 3-30 through 3-34 of EPA/NHTSA (2009).

For fuel economy differences, the TSD gives a range and appears to have rounded the estimates to the nearest percent. Ignoring round-off errors, the largest differences in relative terms are as follows:

- Continuously variable valve lift
- Turbocharged GDI engines with downsizing, where there is some uncertainty regarding the TSD estimate
- Dual-clutch, six-speed, automated manual transmissions
- Stop-start technology.

In some cases, as for the turbocharged GDI engine, the TSD assumptions are not clear because the quoted marginal benefits are inconsistent with the total benefit of turbocharging plus GDI.

For prices, several issues make direct comparisons difficult because the TSD uses a different method to convert cost to RPE than the ICF one used. We see, however, several other specific issues, which we discuss in Section 2. Fuel economy related issues are considered in the following section.

2.0 Technology Unit Retail Price

ICF has concerns about the RPE data in four areas: the RPE for technologies replaced over the life of the vehicle, cost savings of engine cylinder count reduction, costs of diesel engines, and the multiplier used to convert cost to RPE. A more general issue is the adjustment of costs estimated in different years to current dollars using the gross domestic product deflator. It is not clear why this was chosen to adjust costs because it is well known that auto-industry costs have been falling in real terms for the last decade. The Producer Price Index for Automobiles (Bureau of Labor Statistics (BLS) 2010) should be used to adjust costs to constant year numbers.

The first issue is applicable to lubricants and reduced rolling resistance tires. Lubricants are replaced multiple times over a vehicle's life—some may be covered under manufacturers' free service policy and others are paid for by the vehicle owner. Similarly, tires are replaced three to four times over a vehicle's life. The regulatory analysis in the TSD counts only the incremental cost of the first cost.

For the second issue, the cost savings from engine downsizing, the TSD estimates the cost for various engine configurations by using a formula that assumes \$50 per cylinder, \$10 per valve, and \$100 per camshaft, per Table 3-5 in the TSD. Because the cost savings and the cost must be equivalent for not-common parts, the base cost of a four-cylinder, 16-valve DOHC engine would be $\$200 + 160 + 200$, or \$560, and the cost of an in-line six-cylinder DOHC 24-valve engine would be $\$300 + 240 + 200$ or \$740. As a result, the cost difference from cylinder count reduction in this example is only \$180. There is considerable evidence (e.g., Argonne National Laboratory [ANL] submissions [Vyas 1998] to DOE) that the base cost of a "dressed" four-cylinder, 16-valve engine (excluding emissions after treatment) is about \$1,200 to \$1,300, but common parts between the four and six-cylinder engine, like the alternator, oil pump, and water pump, cannot account for the \$700 difference. ICF's work suggests that the engine block changes, crankshaft changes, additional piston, connecting rod, and intake and exhaust system components result in a cost of about \$200 per cylinder. We agree with the \$10/valve estimate, but the price difference between the SOHC and DOHC system is exaggerated because the TSD method fails to account for the rocker arms and the more complex cylinder head assembly for an SOHC 16-valve cylinder head. In fact, Chrysler manufactured an otherwise-identical SOHC and DOHC 2L engine on the same assembly line (for the Dodge Neon) and publicly stated that the cost differential between the two was less than \$50. ICF used \$50 per camshaft and \$5 per valve drive to estimate cost. For the equivalent four-cylinder engine, the cost is the $\$800 + 160 + 100 + 80$, or \$1,140, and for an in-line six-cylinder engine, the cost would be $\$1200 + 240 + 100 + 120$, or \$1,660. Common components would add \$150 to "dressed" engine cost, resulting in total cost estimates of \$1,290 for a four-cylinder engine and \$1,810 for an in-line six cylinder; these are consistent with cost numbers obtained from industry. DOHC V6 costs would be \$100 higher than for an in-line six cylinder, which is more consistent with the difference in costs between in-line and V engines received from industry by ICF than the TSD estimate of \$200. The domestic industry has also typically charged \$900 to \$1,000 for the V6 option relative to a base four cylinder, which is also consistent with the ICF cost-difference estimate of $\$600 \times 1.6$ for calculating RPE.

The third area concerns diesel engine costs. In interviews with the trade press and in public forums, manufacturers have stated that the piece cost of the turbocharged diesel engine is approximately twice the piece cost of a similar displacement gasoline engine (Stephens 2008). This leads to incremental cost estimates of \$1,200 to \$1,300 for a four-cylinder engine per the previous discussion, whereas the EPA estimate is much lower at \$740, based on mature technology costs projected by FEV Inc. in a 2003 report to EPA (FEV 2003). Under a 2005 work assignment for DOE, ICF staff met with German diesel engine manufacturers and fuel injection system suppliers. Based on the inputs received, we concluded that the FEV report had significantly underestimated costs for some components, notably the advanced fuel injection system currently employed in model year (MY) 2010 engines. Specific technologies in the four-cylinder diesel that appear to be underpriced are the advanced fuel injection system with piezo injectors (estimated at \$900 instead of \$630 for a 1800 bar system), the variable geometry turbocharger (estimated at \$260 instead of \$126), and the fuel pump, which is not included in the cost of the fuel injection system (\$45). These three technologies appear to account for most of the price differential. The TSD analysis currently has a far more favorable financial picture for the diesel than actually exists.

The fourth area involving the RPE from costs is drawn from an EPA-sponsored study of this factor conducted in 2009 by RTI International (EPA 2009) using the balance sheets and income statements of auto manufacturers. This study apportioned total costs reported in the income statements to overhead or factor (labor, materials, and energy inputs) costs without much specificity or delineation of accounting terms. The results suggested the 59.4% of total costs were overhead costs and 40.6% were factor costs, so that the multiplier ratio was about 1.46 (59.4/40.6) and the spread among manufacturers was quite small, with all nine manufacturers examined in the study between 1.42 and 1.49. Even if 7% or 8% of the costs were, however, incorrectly classified as factor costs, then the multiplier ratio would be 1.95 to 2.03.

The cost-to-RPE multiplier of about 2 is a ratio widely accepted by industry analysts, but this multiplier is an average for all parts, ranging from those that are basic raw materials like steel sheet or billets to those that are complete subassemblies like a transmission. ICF's analyses for the NAS found several costs that were potentially incorrectly accounted for in the EPA-sponsored study, including factory overhead, new vehicle engineering and development costs not in the R&D budget, and dealer "floor-plan" and facility amortization cost. More important, the EPA study does not examine the difference between the mark-up for a Tier I supplier-based purchase of a manufactured component and the markup starting from basic raw materials like steel. The report does examine the issue of RPE multipliers associated with incremental additions of new technology and develops these multipliers for three levels of technology complexity, low, medium, and high. The incremental multipliers are estimated at 1.02, 1.05, and 1.26 in the long term.

EPA made some adjustments to the reported multipliers to develop new multipliers of 1.07, 1.13, and 1.39, but the specific methodological changes to derive the new values are not documented in the TSD. ICF (unpublished) used a similar classification of technology complexity to derive multipliers of 1.5, 1.62, and 1.75 for subassemblies

purchased from Tier I suppliers to the industry. This results in the EPA estimates for RPE being 25% to 30 % lower than those developed by ICF, but some of the difference is recouped by EPA having a more expansive accounting of costs for some technologies.

3.0 Technology-Specific Fuel Economy Improvement

The fuel economy benefit comparisons in Tables 1-1 through 1-3 also show only small differences in benefit estimates for most technologies, but estimates in Table 1-4 for hybrid and diesel benefits may not be directly comparable because the ICF estimates for these technologies include benefits from “system optimization” such as engine downsizing, and the TSD estimates may not include some or all of these system benefits. DOE has, however, concerns in two areas: the lack of technology specificity associated with some benefits, and the inconsistencies in the estimates for various forms of valve control.

3.1 Technology Specificity

The lack of technology specificity is associated with lubricants, tire improvements, and aerodynamic drag reduction. The benefit values are not associated with specific oil properties, rolling resistance values, or drag coefficients. For example, it is not clear that the benefit of oils is associated with changing from 5W-30 to 5W-20 or 0W-20. Similarly, the specific rolling resistance values of tires in each vehicle class assumed or the values of the drag coefficient assumed are not specified for the future. The TSD reliance on general manufacturer comments instead of peer-reviewed technical papers (see references for examples) on these topics also seems insufficient. These issues may be important in examining manufacturer-specific improvement potential because some manufacturers have already adopted 5W-20 oils (Korcek and Nakada 1995)—some have very low drag vehicles and others have sacrificed low drag for styling statements. The NAS analysis of tires (NAS 2006) shows a significant rolling resistance increase using tires with high speed ratings of 120 to 140 mph simply for image, even though this is far above legal limits for driving anywhere in the United States. Hence, a negative cost fuel economy benefit for some vehicles may be obtained by simply using a lower speed rated tire in some vehicles. Although drag coefficients and tire rolling resistance data are not easily available, EPA has the coast-down data from which these values can be determined at the vehicle nameplate level. A more specific analysis of current usage and expected 2016 usage of these technologies would be very useful.

3.2 Pumping Loss Reduction through Valve Control

One area of significant difference is in benefit estimates for valve control technologies that reduce pumping loss. The TSD states that the fuel consumption benefits of cylinder deactivation scale with the ratio of engine displacement to vehicle weight, cites a benefit range from 0.5% to 6%, and then states that the Honda Odyssey shows a measured benefit of 6%. Yet, the Honda Odyssey has a very low displacement to weight ratio (3.5L engine in a 4,500/ 4,750-lb inertia weight vehicle), but it is at the top end of the stated benefit range. The analysis in the EPA model, however, appears to use the 6% rate, so that there is little disagreement with our estimate in terms of the analytical results.

ICF believes the benefits of continuously variable valve lift (CVVL) should be higher than those of cylinder deactivation because the CVVL system covers a wider range of revolutions per minute (rpm) and load when pumping loss can be reduced relative to

cylinder deactivation, but the estimated benefit in the TSD is lower for CVVL at only 3% to 4%. The benefits are also substantially lower than the benefits claimed by BMW and Nissan (who have such systems on the market) based on measured data. Existing CVVL systems are usually designed to achieve a combination of both lift and valve opening duration change via an intermediate lever mechanism working in conjunction with cam phasers. This approach, also known as “intake throttling,” allows elimination of the conventional throttle unit because the engine air flow can be controlled through real-time adjustment of the inlet valve lift and opening times.

- BMW’s Valvetronic adjusts the valve lift using a lever positioned between the camshaft and the intake valves. The distance from the camshaft is adjusted by an additional eccentric shaft operated by an electric motor. BMW initially marketed the Valvetronic on its higher-end vehicles, but now the technology is available on most of its engines. BMW has claimed that the system achieves a fuel economy improvement of about 12%, but this includes the benefit of dual-cam phasers and reduced friction. Subtracting the variable valve timing (VVT) and friction benefits, the system is expected to yield about 8% fuel economy improvement for CVVL alone. This comparison is for federal test procedure (FTP) cycle conditions and relative to a PFI engine with fixed valve timing and compression ratio.
- Nissan/Hitachi has developed a CVVL system, which they call VVEL (Variable Valve Event and Lift), launched on the MY 2008 Infinity G37 Coupe (Arinaga et al. 2006; Nissan 2007). The system is also designed to throttle air at the intake valves and works in conjunction with VVT control. Figure 2-1 illustrates the CVVL mechanical implementation. The profile of the output cams incorporates ramp section for obtaining smooth lift. The center position of the drive shaft is the same as that of ordinary camshafts. Driven by a chain, the drive shaft undergoes rotational motion that is synchronized to one-half the rotation of the crankshaft. An eccentric drive cam attached to the drive shaft converts the rotational motion of the drive shaft to oscillatory motion, which is transferred to the oscillating output cams by the Link A, rocker arm, and Link B. The direct-current (DC) motor mechanism adjusts the link and rocker arm kinematics to obtain continuous adjustment of the valve lift.
- Engine developers reported that, at low- to mid-load ranges, the intake throttling optimizes the air charge volume. Less valve travel reduces camshaft friction and improves acceleration response by allowing more dense air into the cylinders from the start of acceleration. The timing control opens the valves for a shorter period, preventing blowback of the air-fuel mixture and improving torque. In the high load range, the valve lift is increased, which allows increased air intake to deliver greater torque output.

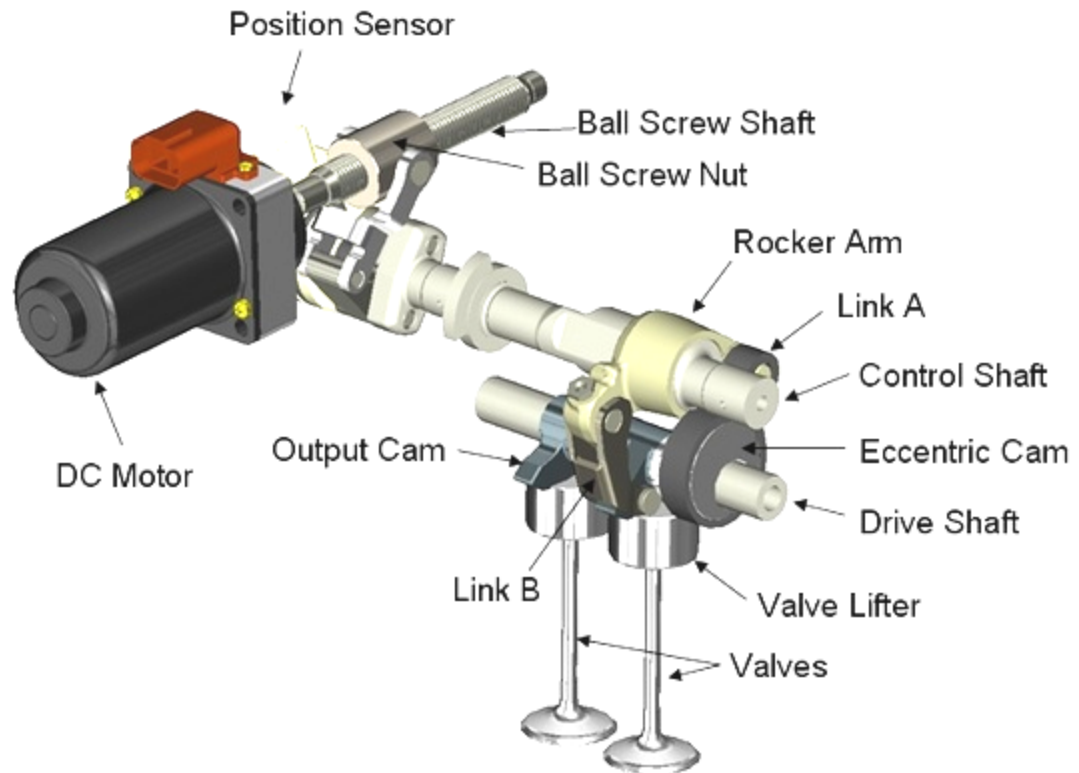

Figure 3-1. Hitachi/Nissan CVVL mechanical implementation

- The VVEL improves fuel efficiency most effectively in the low-to-medium operating range; thus it is best matched to higher displacement engines that typically operate within that range. Nissan has indicated that in high-displacement engines the company will combine VVEL technology with the direct-injection system. The system is capable of “zero lift”; therefore cylinder deactivation is possible in the future. Nissan and Hitachi claim that VVEL adoption, together with VVT, produces up to 20% more power and up to 12% fuel economy improvement (cycle conditions were not reported). This comparison is against an identical engine without CVVL, implying a fixed valve timing engine.
- Also, both Toyota and Honda have announced CVVL systems that they claim are very close to commercialization. Toyota’s version is called Valvematic and is also designed to work with VVT (Toyota 2007). Toyota announcements indicate that the system, installed on a new 2.0L engine (which does include undisclosed additional modifications), improves fuel consumption by 5% to 10% (implying up to 11% fuel economy improvement, depending on driving conditions), boosts output by at least 10%, and enhances acceleration responsiveness. The comparison is likely against the baseline of current Toyota engines, all of which feature VVT, although cycle conditions were not specified.
- Honda’s next-generation VTEC (Variable Valve Timing and Lift Electronic Control) engine will be called AVTEC (or Advanced VTEC). The new system

will combine the continuously variable valve lift system (intake only) with continuously variable timing control (Senate Committee on Energy and Natural Resources 2007). At medium loads, the AVTEC controller creates intake and exhaust valve overlap by advancing the intake valve timing to achieve controlled internal exhaust gas recirculation (EGR). The result is improved fuel consumption and reduced emissions. At high loads, the valve lift is set high and the opening period is widened for improved charging efficiency and performance.

- The ability to continuously adjust the transition between various load modes is crucial in successful system applications. Honda has developed a sophisticated controller for this design, which allows smooth transition to different engine speeds, optimizing fuel consumption, emissions, and performance. Among many resulting efficiency improvements, the new controller allows idle speed reduction from 850 to 600 rpm and still achieves smooth idling. Honda claims that this strategy alone resulted in fuel economy improvement of about 1.7% in the FTP cycle (Tagami et al. 2007). Overall, the new AVTEC system is claimed to improve fuel economy by 13% over current VTEC engines with significant torque increase. Honda’s announcements were made in the United States, so the comparison is potentially for FTP cycle conditions. Table 3-1 summarizes the fuel economy improvements for intake CVVL from the various designs described.

Table 3-1. Fuel Economy Benefits for Various Intake-CVVL Designs

System	Fuel Economy Benefit (%)	VVT Included in FE Benefit?	Notes
BMW Valvetronic	Up to 12	Yes	New European Driving Cycle (NEDC)
Nissan CVVL	Up to 12	Yes	Unspecified cycle
Toyota Valvematic	5 to 11	No	Unspecified cycles
Honda AVTEC	Up to 13	No	Fuel economy benefit compared to VTEC engine

Note: Comparison is against PFI engine with fixed valve timing/lift and fixed CR, with exception of Honda AVTEC, as specified.

Our estimates show that CVVL, when VVT contribution is subtracted, yields about 8% fuel economy benefit. In fact, the estimate appears to be on conservative side because Honda’s AVTEC solution appears to yield higher benefit, if other advantages of fully flexible valve lift and timing control such as idle speed reduction and improved torque are fully exploited.

Finally, the TSD states that product plans show this technology will not be applied by most manufacturers. In contrast, published reports indicate that Honda and Toyota are both readying such systems for market introduction, and others may follow.

3.3. Gasoline Direct Injection and Turbocharging

The TSD reviews estimates for incorporating GDI that range from 1% to 5.8%, but somewhat arbitrarily picks a range of 2% to 3% as “appropriate.” The main mechanism that allows GDI to improve fuel economy, however, is the increase in compression ratio (CR) caused by the cooling effect of fuel spray evaporation in the cylinder. Hence, variability in GDI benefit estimates can be traced to the CR increase assumptions in the studies cited. In addition, other studies have also shown that some GDI benefits arise from combustion improvements facilitated by GDI. Stoichiometric naturally aspirated GDI engines are being used by few OEMs in the United States. Toyota has introduced this technology in the dual injection 3.5L V6 and 4.6L V8 engines used in the Lexus offerings. Volkswagen and Audi are configuring more of their vehicles to adopt the technology labeled FSI (fuel straight injection), and General Motors (GM) has introduced GDI on the 3.0L and 3.6L V6, with additional introductions planned for MY 2010.

- Toyota has adopted a very sophisticated injection strategy that involves both PFI and direct-injection (DI) injector fueling, depending on vehicle operation. The result is a system that achieves very high thermal efficiency in the core mid-to-high load range, which translates into high power (Ueda 2007). The 4.6L V8 was installed on the flagship Lexus LS460. Together with DI, the new engine features new VVT, friction reduction, and other improvements. The engine displacement was increased by about 7% compared to the previous generation LS430, but the new technology was more than enough to compensate for a fuel economy penalty resulting from additional displacement and power increase. Figure 3-2 details the performance and relative fuel economy improvement contribution of various Toyota engine technologies (Asahi et al. 2007). The total fuel economy improvement from the engine is 10% (23 to 25.3 mpg) of which about one-third (or ~3%) is from DI-related changes—CR increase and combustion improvements. The CR increase was only 1.2 (from 10.6 to 11.8) because of the high CR of the base LS430.

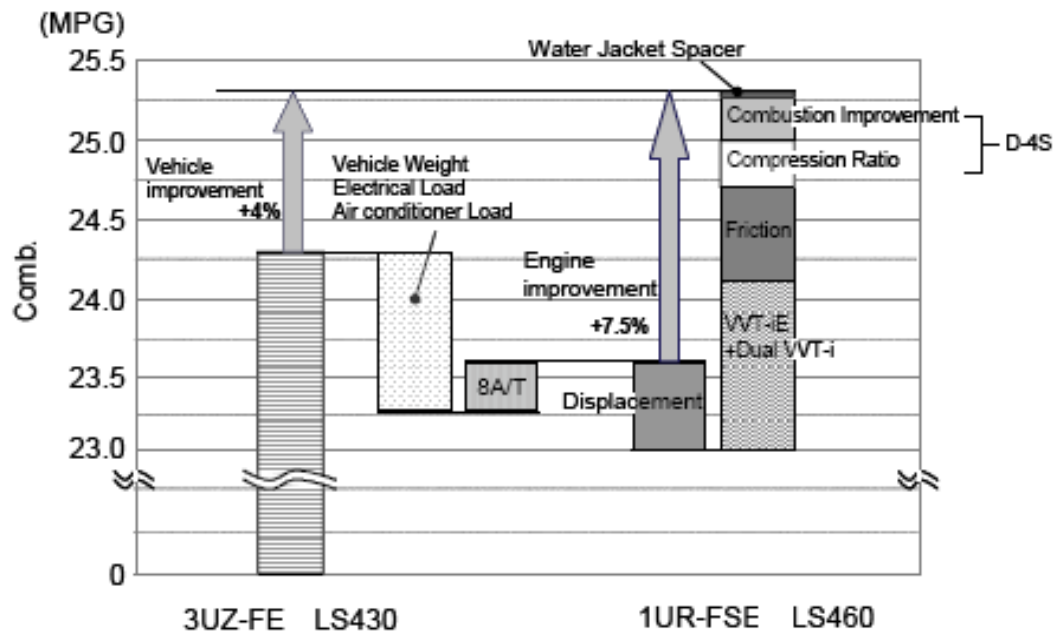

Figure 3-2. LS 460 and LS430 fuel economy comparison—contribution of various engine technologies

The majority of mass market vehicles in the United States in 2008/2009 with PFI engines had CR levels of 9.5 to 10.0, and luxury models certified for premium fuel had CR levels of 10.5 to 11. It appears the GDI can increase CR levels by 2 points to the 11.5–12 range in mass market cars and to 12.5 for luxury cars by 2016. Even in 2009, all Audi GDI V6 engines had a CR of 12.5. GM’s first DI engine, the 3.6L V6, had a CR of 11.3, but the newer 3L introduced for MY 2010 has a CR of 11.7. ICF agrees that if the CR improvement is only 1 to 1.2 points, the fuel economy benefit range in the TSD is reasonable, but it appears that CR will increase by 2 points by 2016 and a benefit range of 3.5% to 4.5% is more appropriate.

Manufacturers agree that the downsized turbocharged GDI engine represents a substantial opportunity to improve fuel economy, and the ICF estimate from measured results on production vehicles comparing the fuel economy of a naturally aspirated engine with that of a turbo GDI engine that is downsized by one third is 13% ± 2%. This is consistent with the statement in the TSD about “a 12 to 14 effectiveness improvement,” but confusingly, the TSD also states that the turbocharged GDI engine “would offer an effectiveness improvement of 2 to 5 percent over a naturally aspirated SGDI engine.” Because the SGDI engine’s benefit is estimated at only 2% to 3%, it is not clear how the two statements are equivalent. In the NHTSA method, the fuel economy is derived from stacking individual technology benefit estimates for GDI and turbocharging separately, and the numbers cited in the TSD would produce inconsistent results if the EPA model assumes a benefit of 12% to 14%.

4.0 Technology Synergy Issues

The issues regarding the net fuel economy benefit of adding multiple technologies to a vehicle have been a source of debate in the fuel economy analysis community, and NHTSA and EPA take different approaches to dealing with these synergy issues, largely because of model-specific differences. The synergy issues are described in more detail in RIAs conducted by each agency.

The Volpe model used by NHTSA organizes technologies into predetermined sequences of adoption, termed decision trees. Because the model applies technologies individually, NHTSA tracks synergistic effects between pairings of individual technologies in a manner similar to that used in the DOE's National Energy Modeling System (NEMS). Inputs to the Volpe model incorporate technology pairs identified in NEMS as well as additional pairs from the set of technologies considered uniquely in the Volpe model. For this rulemaking, NHTSA updated the list of technologies and expanded the list of synergy pairings.

NHTSA does not account for synergies within a particular decision tree because the synergies are already accounted for within the incremental effectiveness values assigned for each technology in the input files used by the Volpe model. Hence, the technology benefits represent the net benefit of the technology given all the previous technologies adopted in the decision tree method. For applying incremental synergy factors between two or more decision trees, the Volpe model uses input tables with synergy factors identified by vehicle class shown in Tables V-12 a-d of NHTSA 2009.

The tables present a lengthy list of technology pairs, and list the technology synergy (or more accurately, "dis-synergy" because most are negative) for each pair and for several vehicle size classes, although we were unable to discern any change in the listing across size classes. These numbers were derived from the EPA lumped-parameter model, according to the description in the NHTSA RIA. The data in the synergy tables were not reviewed directly because the method and results of the EPA model were reviewed.

EPA was not satisfied with the NEMS model method because it depends on an assumed technology adoption path and, furthermore, the NEMS does not account for some newer technologies. As a result, EPA developed its own estimates using the lumped-parameter approach. EPA describes the lumped-parameter analysis as a first-principles-based energy balance, to account for all the different categories of energy loss, including:

- Second law of thermodynamics-based losses
- Heat loss from the combusted gases to the exhaust and coolant
- Pumping loss
- Mechanical friction loss
- Transmission losses
- Accessory loads

- Vehicle road-load tire and aerodynamic drag losses
- Vehicle inertial energy lost to the brakes.

EPA does not, however, document how the various losses were determined for the baseline vehicle, other than stating that “it is assumed that the baseline vehicle has a fixed percentage of fuel lost to each category.” Each technology improvement is characterized by the percent change to each of the loss categories. Hence, if multiple technologies are employed to reduce the same category of losses, each successive technology has a smaller impact as the category of loss is reduced to zero. EPA does not document how the technology characterization was done. It appears, however, that these determinations of losses both for the baseline vehicle and for technology improvements were not based on computed values but on expert opinion, as far as we can determine.

EPA compared the lumped-parameter results with new full-scale simulation modeling results on several vehicle classes with different combinations of planned technological improvements. Ricardo Inc. performed the simulations and documented them in a separate report (Ricardo 2008). In a majority of the comparisons, the lumped-parameter model estimates were close to the Ricardo estimate, and EPA concluded the results of their model were plausible, with a few technology packages requiring “additional investigation.” EPA indicates in the RIA that the agency will continue to use the lumped-parameter approach as an analytical tool, and may adjust the lumped-parameter model as necessary in the future to improve its fidelity as more simulation results become available.

ICF- EEA also developed a lumped-parameter model that is broadly similar in scope and content to the EPA model. The primary difference is that all of the baseline vehicle’s energy losses are determined computationally, and many of the technology effects on each source of loss were determined from data presented at technical conferences. Because the model has been used primarily for internal purposes, a detailed documentation of all facets of the model is not available, but a short summary is as follows.

First, the energy required at the wheel to move a vehicle over the driving cycle has been determined as a function of its weight, frontal area, drag coefficient, and tire rolling resistance coefficient by numerical integration over the Federal Test Procedure city and highway driving cycles in a paper by GM researchers (Sovran and Bohn 1981). This is used to compute the energy requirement at the wheel for the given baseline vehicle and translated to energy at the engine output shaft by using transmission and driveline efficiency factors (which differ by transmission type and number of gears) derived from the open literature. Accessory energy requirements are added as a fixed energy amount that is a function of engine size. This determines total engine output energy; average cycle power is then computed by distributing the energy over the cycle time when positive engine output is required; i.e., the time spent at closed throttle braking and idle are accounted for separately. Average cycle rpm excluding idle was obtained for specific vehicles from simulation models on specific vehicles, and these data are scaled by the ratio of the N/V for the data vehicle and the baseline vehicle. These data are used to

determine average brake mean effective pressure (BMEP) for the positive power portion of the cycle.

Fuel consumption is determined from the relationship:

$$\text{IMEP} = \text{BMEP} + \text{FMEP} + \text{PMEP},$$

where I is for indicated, F is for friction, and P is for pumping. The fuel consumption model is derived from a method to estimate an engine map using a semiempirical model developed by researchers at Ford and the University of Nottingham, as described in Shayler et al. (1999). In this formulation, fuel consumption is proportional to IMEP divided by indicated thermal efficiency (sometimes called the Willans line), friction is determined empirically from engine layout and is a function of rpm only, and PMEP is simply intake manifold pressure–atmospheric pressure. Intake manifold pressure is solved for any given BMEP because IMEP is also proportional to intake pressure. This model explicitly derives thermal efficiency, friction loss, and pumping loss for the baseline vehicle. Fuel consumption at idle and closed throttle braking are modeled as functions of engine displacement only. The baseline engine is always modeled with fixed valve lift and timing, and the pumping loss is adjusted for the presence of VVT if applicable. The model can be construed as a 2-point approximation of a complete engine map and is a very reasonable representation of fuel consumption at light and moderate loads where there is no fuel enrichment.

The technologies are characterized by their effect on each of the losses explicitly accounted for in the model, and the representation is similar in concept to the representation in the EPA model. The model outputs were also compared to the Ricardo simulation results that were used a reference standard by EPA. The Ricardo work modeled five baseline vehicles (standard car, large car, small multi-purpose vehicle (MPV), large MPV, and large truck) and 26 technology combinations, covering gasoline and diesel power trains used in the EPA model, but there was no simulation of hybrids.

ICF–EEA had also performed an initial analysis for the NAS Committee on Fuel Economy. Based on our experience, when a number of engine, transmission, and other technology improvements are simultaneously added to a baseline vehicle, the net fuel economy benefit can be approximated by taking 90% of the additive sum of the individual technology benefits. We used this technique to develop a quick approximation of the level of agreement likely between the Ricardo simulations and our lumped-parameter model. We performed a quick analysis of 23 of 26 packages developed by Ricardo; we had no data on homogeneous charge compression ignition (HCCI) engines, which were used in 3 of the technology packages modeled by Ricardo.

Ricardo included one technology for which we had no specific data, which they defined as “fast warm-up” technology. This is the control of coolant flow to the engine immediately after cold start. Based on the data presented by Ricardo, we estimated this technology’s benefit at 1%, including the benefit of the electric water pump. All other technology benefits were based on the data from ICF–EEA’s previous reports to the DOE on fuel economy technology. These benefit estimates were adjusted for the presence or

absence of technologies on the baseline vehicle, because all benefits in the DOE reports were typically defined relative to an engine with fixed valve timing and a four-speed automatic transmission. Figure 4-1 illustrates the results, and the plot shows the difference between the Ricardo results and the quick approximation method.

In 16 of the 23 cases, the Ricardo estimate is within 5% of the quick estimate. In two cases, the Ricardo estimates were more than 10% lower relative to the quick estimates. In five cases, the Ricardo estimates were 10% (or more) higher than the quick estimate. Note that the difference implies that the benefits are larger than the simple sum of individual technology benefits and that technology synergies are positive. We also examined the technology packages in the two “low” and five “high” outliers. Both low outliers had technology packages with a continuously variable transmission (CVT) as one of the technologies. The five high outliers did not feature any major technology improvement in common.

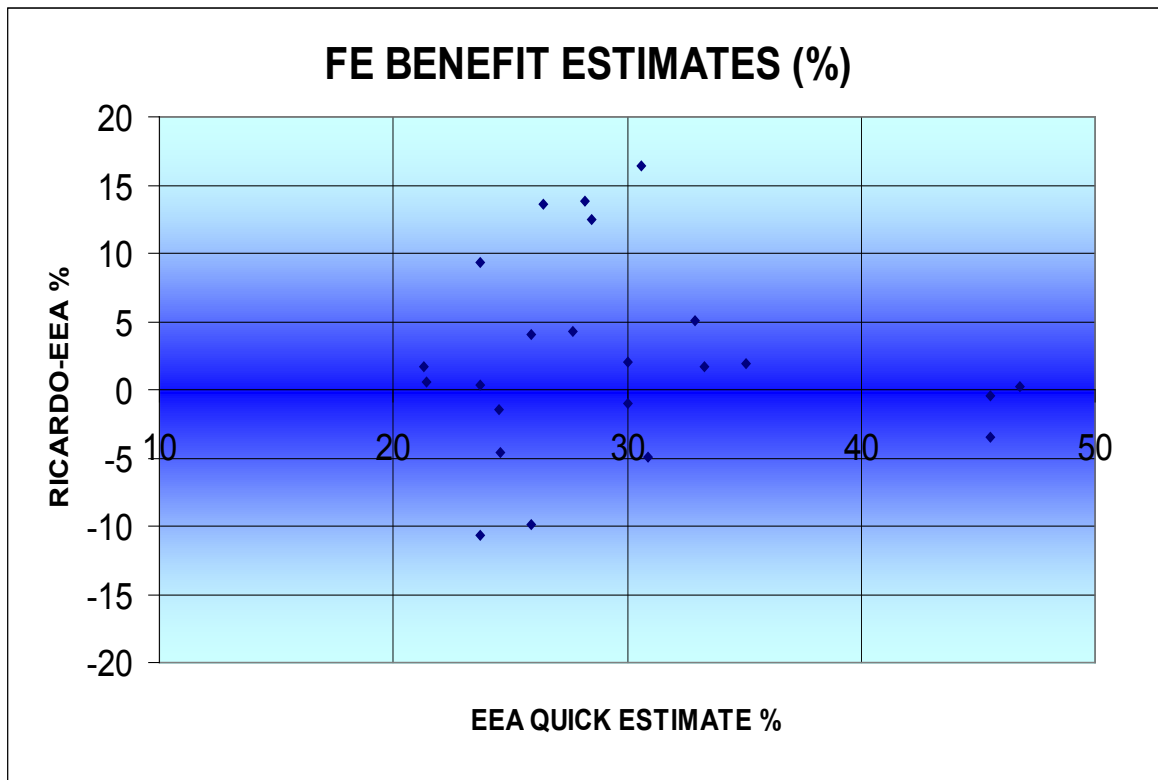

Figure 4-1. Comparison of the difference between Ricardo and EEA fuel economy simulation results

More detailed analysis was also done with the ICF-EEA lumped-parameter model. Because of resource and time constraints, we analyzed only 9 of the 23 cases with the lumped-parameter model, but the 9 cases included both high and low outliers from the previous analysis. Three technology packages were analyzed for the “standard car,” which used a Toyota Camry baseline; three for the compact van, which used the Chrysler Voyager as a baseline; and three for the standard pickup, which used the Ford F-150 as the baseline. Table 4-1 shows the results as well as the “quick” method results, for

comparison. The more detailed modeling reduced the average difference between the Ricardo estimates and our estimates for the Toyota Camry and the Chrysler compact van, but increased the difference for the Ford F150 truck. The largest observed difference is for package 10 on the Ford, where the baseline 5.4L V8 is replaced by a 3.6L V6 turbo GDI engine, and the downsizing is consistent with the 33% reduction we have used.

Table 4-1. Results from the lumped-parameter model

Vehicle	Tech. Package	Ricardo Estimate	“Quick” Result	EEA Model Result
Toyota Camry	Z	33.0	23.7	32.6
	1	13.0	23.7	23.1
	2	22.0	22.4	21.9
	RMS		8.15	5.85
	Difference			
Chrysler Voyager	4	26.0	30.9	29.9
	6b	35.5	33.3	35.5
	16	41.0	28.5	36.6
	RMS		7.85	3.39
	Difference			
Ford F-150	9	32.0	30.0	28.3
	10	42.0	28.2	26.4
	16	23.0	21.3	23.4
	RMS		8.12	9.25
	Difference			

In Table 4-1, the RMS difference refers to the root mean square difference between the ICF-EEA estimate and the Ricardo estimate. The differences seem to be in the same range as the differences between the EPA estimates with their lumped-parameter model and the Ricardo estimates. It is also important to note that the EPA model results are more consistent with the results of the ICF model. The “low” Ricardo result for package 1 on the Camry is also significantly lower than the EPA estimate of 20.5% fuel economy benefit, which is closer to the ICF 23% estimate than to Ricardo’s 13% estimate. Similarly, the high Ricardo estimate for package 10 on the Ford F-150 is also substantially higher than the EPA estimate of 30.5% fuel economy gain, which is, in turn, higher than our estimate of 26.4% but much less than the Ricardo estimate of 42%.

In conclusion, the EPA synergy model appears to produce results reasonably consistent with the ICF model, but suffers from not having computationally specific inputs on the baseline vehicle and a more rigorous approach to determining pumping and friction components of loss. We disagree with the EPA approach of using the Ricardo simulation as the reference standard, because we believe that the detailed simulation model is also subject to user input biases. In this case, for example, we believe that Ricardo used a map of an inefficient CVT to derive results much lower than the benefits being demonstrated by vehicles in certification testing.

5.0 References

- Arinaga, T.; Kobayashi, M.; Ushijima, K.; Takemura, S.; Aoyama, S.; Nakamura, M. Hara, S. (2006). *A Study of Friction Characteristics of Continuously Variable Valve Event and Lift (VEL) System*. SAE Technical Paper 2006-01-0222. Warrendale, PA: SAE.
- Asahi, T.; Yamada, T.; Hashizume, H. (April 2007). “The New 4.6L V8 SI Engine for the Lexus LS460.” Presented at the Vienna Motor Symposium, Vienna, Austria.
- BLS. (2010). Producer Price Index for Automobiles. Available at www.bls.gov/ppi/. Washington, DC: BLS
- EPA. (2009). *Automobile Industry Retail Price Equivalent and Indirect Cost Multipliers*. EPA Report 420-R-09-003. Washington, DC: EPA.
- EPA and NHTSA. (September 2009). *Draft Joint Technical Support Document, Proposed Rulemaking to Establish Light-Duty Vehicle Greenhouse Gas Emission Standards and Corporate Average Fuel Economy Standards*. Washington, DC: EPA and NHTSA.
- FEV Inc. (2003). *FEV Engine Technology, Cost and Fuel Economy Comparison of Diesel and Gasoline Powertrains in Passenger Cars and Light Duty Trucks*. FEV report to EPA under Contract No. 68-C-01-155. Aachen, Germany: FEV.
- ICF. Unpublished analysis in support of the National Academy of Sciences Committee on Fuel Economy.
- ICF-EEA (2007) . *Advanced Technologies to Improve Fuel Economy of Light Duty Vehicles*. Report to the US DOE. Fairfax, VA: EAA
- Korcek, S.; Nakada, M. (1995). “Engine Oil Performance Requirements and Reformulation for Future Engines and Systems.” Presented at the International Tribology Conference, Yokohama, Japan, October.
- NAS. (2001). *Effectiveness and Impact of Corporate Average Fuel Economy (CAFÉ) Standards*. Report of the Committee on the Effectiveness and Impacts of CAFE Standards. Washington, DC: NAS Press.
- NAS. (2006). *Tires and Passenger Vehicle Fuel Economy*. National Academy of Sciences Special Report 286. Washington, DC: NAS Press.
- NHTSA. (2009). *Preliminary Regulatory Impact Analysis: Corporate Average Fuel Economy for MY 2012-MY2016 Passenger Cars and Light Trucks*. Washington DC: NHTSA

Nissan. (March 29, 2007). "Nissan Introduces Innovative Engine Valve Control Technology—Variable Valve Event & Lift (VVEL) Delivers Significant Improvements in Dynamic and Environmental Performance." News release.

Ricardo, Inc. (2008). *A Study of the Potential Effectiveness of Carbon Dioxide Reducing Vehicle Technologies*. Report to the U.S. EPA. June 26. Van Buren, MI: Ricardo Inc.

Shayler, P.; Chick, J.; Eade, D. (March 1999). *A Method of Predicting Brake Specific Fuel Consumption Maps*. SAE Paper 1999-01-0556. Warrendale, PA: SAE.

Sovran, G.; Bohn, M. (February 1981). *Formulae for the Tractive Energy Requirements of the Vehicles Driving the EPA Schedules*. SAE Paper 810184. Warrendale, PA: SAE.

Senate Committee on Energy and Natural Resources. (January 30, 2007). *Statement of John German, Manager, Environmental and Energy Analysis, Product Regulatory Office, American Honda Motor Company, Inc.* Washington, DC: U.S. Senate.

Stephens, T. (2008). "GM's Advanced Propulsion Technology Strategy." Presented at the 29th International Vienna Motor Symposium, Vienna, Austria, April.

Tagami, H.; Yasui, Y.; Sato, M.; Ito, H. (2007). *Management System for Continuously Variable Valve Lift Gasoline Engine*. SAE Technical Paper 2007-01-1200. Warrendale, PA: SAE.

Toyota. (June 12, 2007). "Toyota Develops Next-Generation Engine Valve Mechanism." News release.

Ueda, T. (2007). "Innovative Development Methodology Based on the Toyota Way." Presented at the Vienna Motor Symposium, Vienna, Austria, April.

Vyas, A. (December 1998). *HEV Component Cost Information*. ANL report to DOE. Argonne, IL: ANL.

REPORT DOCUMENTATION PAGE

Form Approved
OMB No. 0704-0188

The public reporting burden for this collection of information is estimated to average 1 hour per response, including the time for reviewing instructions, searching existing data sources, gathering and maintaining the data needed, and completing and reviewing the collection of information. Send comments regarding this burden estimate or any other aspect of this collection of information, including suggestions for reducing the burden, to Department of Defense, Executive Services and Communications Directorate (0704-0188). Respondents should be aware that notwithstanding any other provision of law, no person shall be subject to any penalty for failing to comply with a collection of information if it does not display a currently valid OMB control number.

PLEASE DO NOT RETURN YOUR FORM TO THE ABOVE ORGANIZATION.

1. REPORT DATE (DD-MM-YYYY) February 2011		2. REPORT TYPE Subcontract Report		3. DATES COVERED (From - To)	
4. TITLE AND SUBTITLE Comparison of Vehicle Efficiency Technology Attributes and Synergy Estimates			5a. CONTRACT NUMBER DE-AC36-08GO28308		
			5b. GRANT NUMBER		
			5c. PROGRAM ELEMENT NUMBER		
6. AUTHOR(S) G. Duleep			5d. PROJECT NUMBER NREL/SR-6A20-47806		
			5e. TASK NUMBER IGIN9311		
			5f. WORK UNIT NUMBER		
7. PERFORMING ORGANIZATION NAME(S) AND ADDRESS(ES) ICF Incorporated, LLC. 9300 LEE HIGHWAY FAIRFAX, VA 22031-1207			8. PERFORMING ORGANIZATION REPORT NUMBER KACX-8-88312-00		
9. SPONSORING/MONITORING AGENCY NAME(S) AND ADDRESS(ES) National Renewable Energy Laboratory 1617 Cole Blvd. Golden, CO 80401-3393			10. SPONSOR/MONITOR'S ACRONYM(S) NREL		
			11. SPONSORING/MONITORING AGENCY REPORT NUMBER NREL/SR-6A20-47806		
12. DISTRIBUTION AVAILABILITY STATEMENT National Technical Information Service U.S. Department of Commerce 5285 Port Royal Road Springfield, VA 22161					
13. SUPPLEMENTARY NOTES NREL Technical Monitor: Caley Johnson					
14. ABSTRACT (Maximum 200 Words) Analyzing the future fuel economy of light-duty vehicles (LDVs) requires detailed knowledge of the vehicle technologies available to improve LDV fuel economy. The National Highway Transportation Safety Administration (NHTSA) has been relying on technology data from a 2001 National Academy of Sciences (NAS) study (NAS 2001) on corporate average fuel economy (CAFE) standards, but the technology parameters were updated in the new proposed rulemaking (EPA and NHTSA 2009) to set CAFE and greenhouse gas standards for the 2011 to 2016 period. The update is based largely on an Environmental Protection Agency (EPA) analysis of technology attributes augmented by NHTSA data and contractor staff assessments. These technology cost and performance data were documented in the Draft Joint Technical Support Document (TSD) issued by EPA and NHTSA in September 2009 (EPA/NHTSA 2009). For these tasks, the Energy and Environmental Analysis (EEA) division of ICF International (ICF) examined each technology and technology package in the Draft TSD and assessed their costs and performance potential based on U.S. Department of Energy (DOE) program assessments. ICF also assessed the technologies' other relevant attributes based on data from actual production vehicles and from recently published technical articles in engineering journals. ICF examined technology synergy issues through an ICF in-house model that uses a discrete parameter approach.					
15. SUBJECT TERMS NREL; light-duty vehicles; LDV; fuel economy; vehicle efficiency; vehicle synergies; EPA; ICF International; technology synergy; technology cost; technology performance; Department of Energy; DOE; energy model					
16. SECURITY CLASSIFICATION OF:			17. LIMITATION OF ABSTRACT UL	18. NUMBER OF PAGES	19a. NAME OF RESPONSIBLE PERSON
a. REPORT Unclassified	b. ABSTRACT Unclassified	c. THIS PAGE Unclassified			19b. TELEPHONE NUMBER (Include area code)