

Development of a Cummins Westport SI-EGR Natural Gas Engine at 0.2 g/bhp-hr

February 2, 2005 — July 31, 2006

M. Kamel
*Cummins Westport
Vancouver, British Columbia, Canada*

Subcontract Report
NREL/SR-540-40757
October 2006

NREL is operated by Midwest Research Institute • Battelle Contract No. DE-AC36-99-GO10337



Development of a Cummins Westport SI-EGR Natural Gas Engine at 0.2 g/bhp-hr

February 2, 2005 — July 31, 2006

M. Kamel
Cummins Westport
Vancouver, British Columbia, Canada

NREL Technical Monitor: A. Williams
Prepared under Subcontract No. ZCI-5-44118-01

Subcontract Report
NREL/SR-540-40757
October 2006

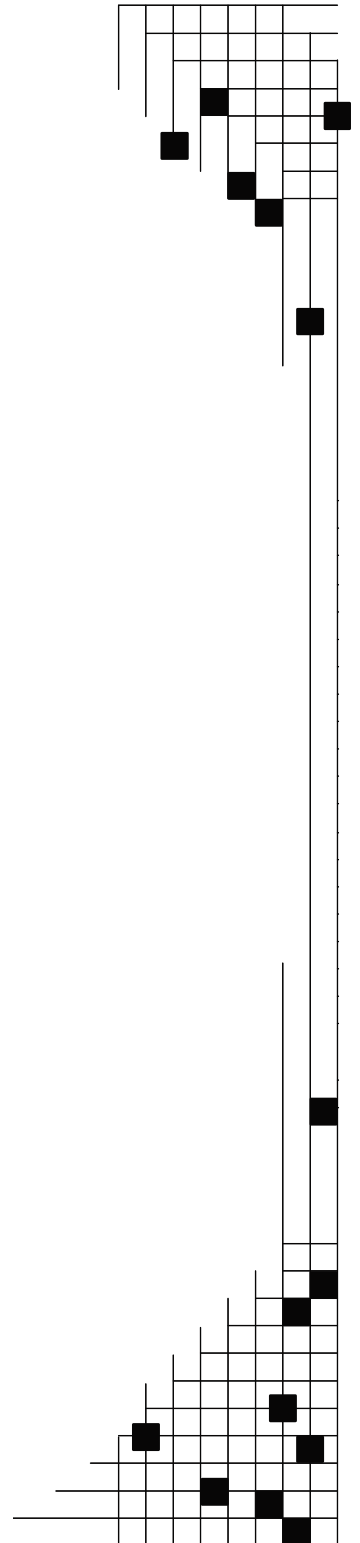

National Renewable Energy Laboratory
1617 Cole Boulevard, Golden, Colorado 80401-3393
303-275-3000 • www.nrel.gov

Operated for the U.S. Department of Energy
Office of Energy Efficiency and Renewable Energy
by Midwest Research Institute • Battelle

Contract No. DE-AC36-99-GO10337

**This publication was reproduced from the best available copy
Submitted by the subcontractor and received no editorial review at NREL**

NOTICE

This report was prepared as an account of work sponsored by an agency of the United States government. Neither the United States government nor any agency thereof, nor any of their employees, makes any warranty, express or implied, or assumes any legal liability or responsibility for the accuracy, completeness, or usefulness of any information, apparatus, product, or process disclosed, or represents that its use would not infringe privately owned rights. Reference herein to any specific commercial product, process, or service by trade name, trademark, manufacturer, or otherwise does not necessarily constitute or imply its endorsement, recommendation, or favoring by the United States government or any agency thereof. The views and opinions of authors expressed herein do not necessarily state or reflect those of the United States government or any agency thereof.

Available electronically at <http://www.osti.gov/bridge>

Available for a processing fee to U.S. Department of Energy
and its contractors, in paper, from:

U.S. Department of Energy
Office of Scientific and Technical Information
P.O. Box 62
Oak Ridge, TN 37831-0062
phone: 865.576.8401
fax: 865.576.5728
email: <mailto:reports@adonis.osti.gov>

Available for sale to the public, in paper, from:

U.S. Department of Commerce
National Technical Information Service
5285 Port Royal Road
Springfield, VA 22161
phone: 800.553.6847
fax: 703.605.6900
email: orders@ntis.fedworld.gov
online ordering: <http://www.ntis.gov/ordering.htm>



Table of Contents

Executive Summary 1

Introduction 1

Program Objectives 2

Development Schedule..... 2

Task 1: Concept Demonstration..... 3

Task 1.1 Concept Design 3

Task 1.2: Concept Engine..... 4

Task 2: Design and Development 5

Task 2.1: Performance and Emissions Development 5

Task 2.2: Control System Development 9

Task 2.3: Design Optimization, Structure & Release 11

Task 3: Design Verification & Validation 14

Task 3.1: Engineering Vehicle Test..... 14

Task 3.2: Alpha Engine Builds 15

Conclusions..... 16

Executive Summary

Due to the limitations of lean burn gas engine technology, a program was initiated to develop and demonstrate advanced technologies and methods for controlling exhaust emissions in a medium-duty natural gas engine to meet 2010 Federal emission standards. The program has accomplished the objectives of Phase I development. A concept design was completed and an engine was built based on the design which had the required features for cooled Exhaust Gas Recirculation. Test Cell based control system was used to operate the engine in a sufficient manner to demonstrate that the concept can achieve the desired power output of 320 HP. The concept design and major hardware e.g. turbocharger, combustion chamber and mixer was based upon considerable analysis and predictive techniques.

Hardware revisions to a new Cummins Inc. engine control module (ECM) were necessary to accommodate the new system requirements for sensors and actuators for the engine. These were undertaken and a new concept ECM was developed and used for this initial phase of development. The ECM and control system were used to operate the development engines after the concept phase was completed. Algorithm and software development is a major element of this new technology engine concept.

Suppliers of 3-way catalysts were engaged and prototype parts were procured. Emissions development work demonstrated that the engine technology combined with the catalyst technology is able to reach the target emissions. Data was obtained using the transient FTP test cycle.

One engine was built to evaluate the performance of the concept design in the target market. The engine was installed in an Engineering vehicle (1993 International Model 9700 Highway Tractor, 6 x 4 cab over, sleeper-body) and used as part of the development process.

Six field test engines were built and shipped to end user sites for installation in vehicle to evaluate performance, reliability and customer acceptance in the field.

Introduction

The U.S. Department of Energy (DOE) supports Natural Gas Vehicle (NGV) research through its FreedomCAR and Vehicle Technologies (FCVT) Program to help the United States reduce its dependence on imported petroleum. Additionally, NGVs can reduce emissions of regulated pollutants compared with diesel vehicles, and the development of NGV technology may also facilitate development of hydrogen vehicle technology.

The National Renewable Energy Laboratory (NREL) is the field manager for the DOE's Next Generation Natural Gas Vehicle (NGNGV) Program. NGNGV activities are developing advanced, commercially viable, medium- and heavy-duty natural gas engines and vehicles that will meet EPA 2007/2010 heavy-duty emission regulations before 2007. In addition to the petroleum displacement these natural gas engines offer, all engines produced before 2007 that are certified to 2010 standards will be eligible for emission credits.

Changes to Federal and California emission standards have advanced emission control technologies in diesel engines. Today, most OEM engine manufacturers utilize exhaust gas recirculation (EGR) to meet the 2004 emission standards. EGR not only helps

conventional fuels like diesel to reduce NOx, but natural gas fueled engines can benefit as well.

The NGNGV program goals for these new vehicles are oxides of nitrogen (NO_x) emissions at or below 0.2 g/bhp-hr and particulate matter (PM) emissions at or below 0.01g/bhp-hr as measured in accordance with the Federal Test Procedure.

Program Objectives

The objective of this Statement of Work is to develop and demonstrate advanced technologies and methods for controlling exhaust emissions in a medium-duty natural gas engine to meet 2010 Federal and California emission standards by 2007.

Specific objectives include:

- Develop a natural gas engine capable of 2010 emission standards (g/bhp*h); 0.2 NOx, 0.14 nmHC, 0.01 PM and 15.5 CO.
- Engine ratings of 320 h.p. and 1000 lbs.*ft.
- Demonstrate and document engine performance.

Development Schedule

Table 1 below reflects the three major tasks and the corresponding sub-tasks for the L Gas Plus '07 development. This report covers only Phase 1 of the development which is for the first 14 months of development and includes Tasks 1 and 2. The project is continuing the development of the engine with some other funding sources.

"L Gas Plus '07" Development		Months																													
Task #	MILESTONE NAME	1	2	3	4	5	6	7	8	9	10	11	12	13	14	15	16	17	18	19	20	21	22	23	24	25	26	27	28	29	30
1	Concept Demonstration																														
1.1	Concept Design																														
1.2	Concept Engine																														
2	Design & Development																														
2.1	Performance & Emissions Development																														
2.2	Control System Development																														
2.3	Design optimization Structure & Release																														
3	Design Verification & Validation																														
3.1	Engineering Vehicle Tests																														
3.2	Alpha Engine Builds																														
3.3	Alpha Engine Installations																														
3.4	Field Test Operation (Alpha Engines / Vehicles)																														
3.5	Mechanical Development																														
4	Product Launch Readiness																														
4.1	Parts Sourcing																														
4.2	Assembly Procedures																														
4.3	Beta Engine Builds																														
4.4	Emissions Certification																														
5.1	Reliability Assessment																														

Table 1: L Gas Plus '07 Development Schedule

Task 1. Concept Demonstration

Task 1.1 Concept Design

In this task the concept design was completed outlining the layout of the engine and the subsystems needed to achieve the goals of the project. Analysis work was utilized to help define some of the engine components for initial evaluation. Designs of the majority of the engine parts were completed at a concept stage to facilitate identifying the configuration of the engine and the initial vision bill of material.

Figure (1) is a layout of the concept engine design including all the major subsystem and the architecture of the engine. The design facilitated mounting the required Exhaust Gas Recirculation (EGR) hardware, EGR cooler, EGR control valve which were all new components. Plumbing of these components required special arrangements to be made as seen in Fig (1). In addition Fuel and Ignition system components from current production engines were incorporated into the design. The engine control system for the concept phase was not to be engine mounted. Test cell based system was adapted for this phase.

Turbocharger matching work was conducted through the use of cycle simulation computer program. A suitable turbocharger configuration was identified which required an adaptor be designed to interface between the turbocharger and the exhaust manifold.

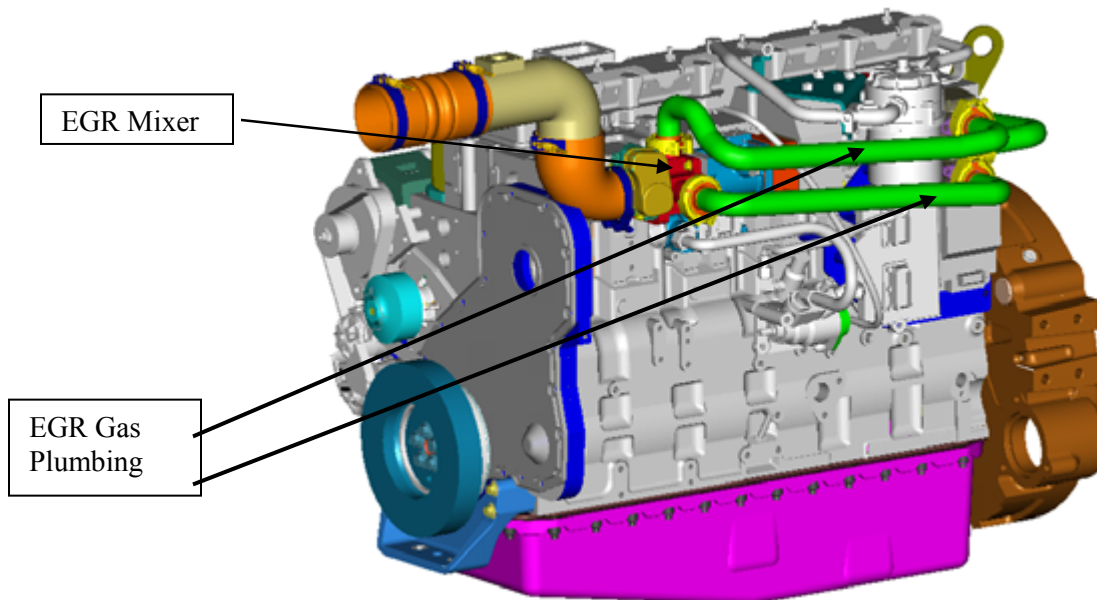

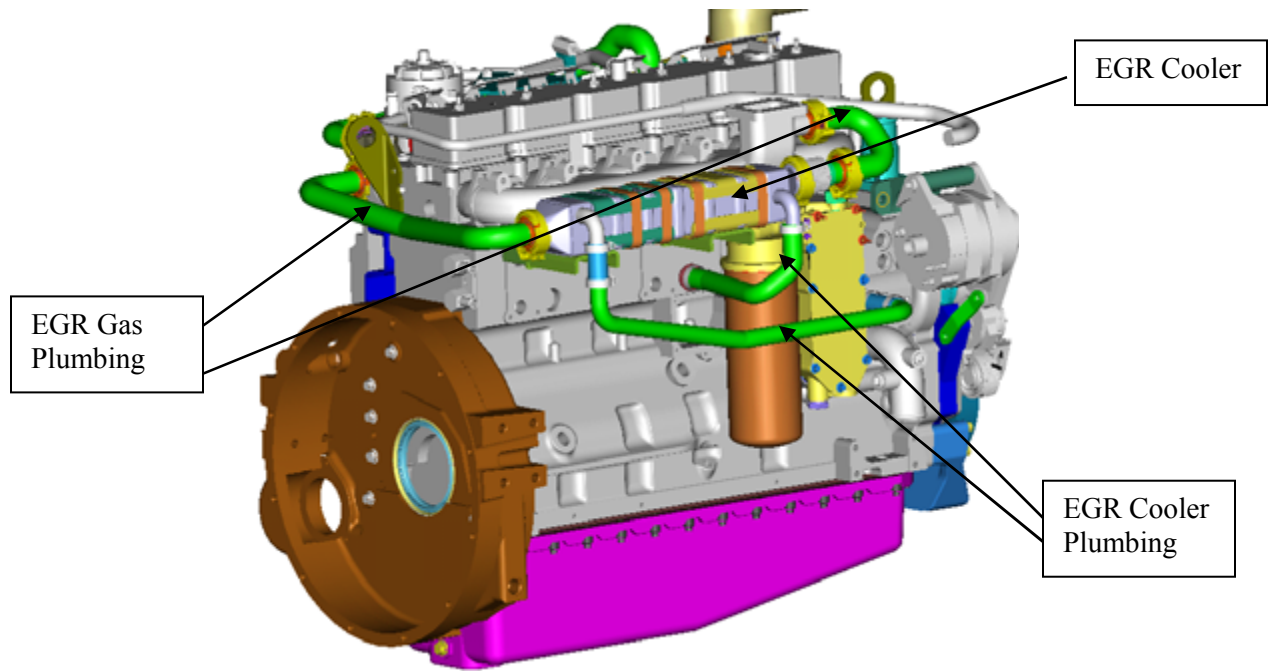

Figure (1) Concept Engine Design layout

Task 1.2 Concept Engine

In this task, prototype hardware was procured based on the concept design. The hardware was used to build a concept demonstration engine. Figure (2) below is a picture of the concept engine which was assembled and installed in a test cell and operated to obtain initial performance data to demonstrate the capability of the design concept to achieve the target rating.

The selected turbocharger is a wastegated design and the size and capability of the configuration was determined through cycle simulation analysis. The cylinder head, block and rotating assemblies except for the piston are of the current lean burn gas engine designs. The ignition system for the concept phase consisted of the lean burn gas engine components. The EGR cooler used was a developmental part from the diesel engine program. The fuel system components are current production parts. The details of the control system are given in a following section.



Figure (2) Concept Engine

Task 2. Design and Development

Task 2.1 Performance and Emissions Development

This task includes all aspects of combustion chamber design, turbo machinery development, EGR system development, and performance and emissions development. Steady state and transient emissions development activities are also included in this task. Performance and emissions recipe development for the concept, field test and production engines are completed within this task. Due to the early termination of this contract only the phase 1 of the development will be covered.

Extensive combustion chamber design analysis was conducted as well as review of prior research work conducted at Cummins Inc. on similar concept engines. The bowl shape was designed to convert the induction swirl into high turbulence intensity and therefore fast combustion.

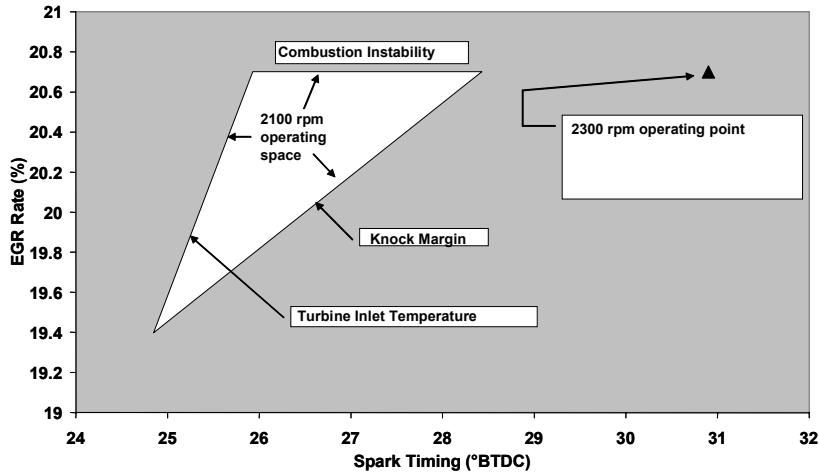

Figure (3): Operating Margin at Rated Conditions

This piston design was used for the initial concept development work. Difficulties were encountered in achieving the target power output of 320HP at 2300rpm with sufficient operating margin to account for system variability. As seen in Figure (3), although the output power can be achieved at 2300 rpm, there was no operating margin and therefore this is not a suitable design for a production engine. Further work concluded that the operating margin can be significantly increased by decreasing the rated engine speed from 2300 to 2100 rpm. This change was evaluated by Cummins power train experts and deemed acceptable for vehicle operation. The engine operating triangle is defined by turbine inlet temperature, combustion stability and knocking limits. As a result the target torque curve for the engine was changed and the final curve is shown in Figure (4). Also shown in Figure 4 is a second torque curve that was requested for the project for a lower rating at 280 HP output.

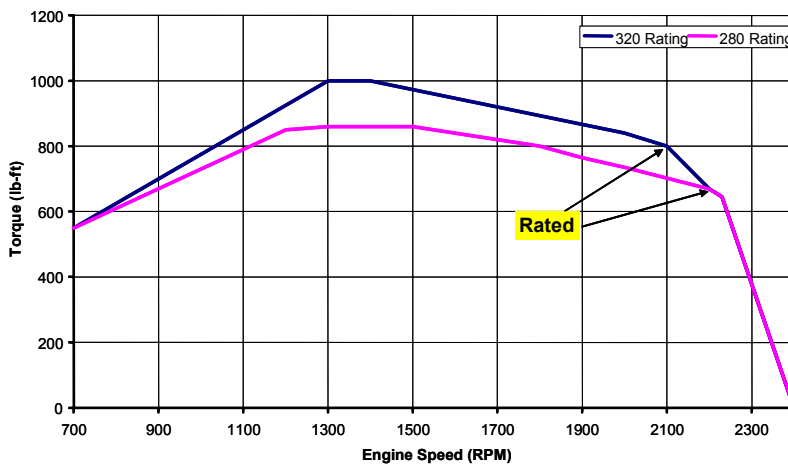

Figure (4): Final Targeted torque Curve

Emissions development consisted of steady state, transient tests as well as catalyst development. Catalyst suppliers were consulted to provide concept hardware option for 3-way designs to achieve the target NOx emissions reduction (95%). Hardware was procured for engine test. Engine calibrations were developed to provide engine out NOx emissions not exceeding 4 g/bhp.hr. Engine and catalyst combination were tested in the transient emissions test cell on the standard FTP test cycle. Results are shown in Figures (5,a-d) and demonstrate that the concept engine with the catalyst can achieve the target emissions of 0.2 g/bhp.hr NOx as well as all the other elements of CO, NMHC and PM.

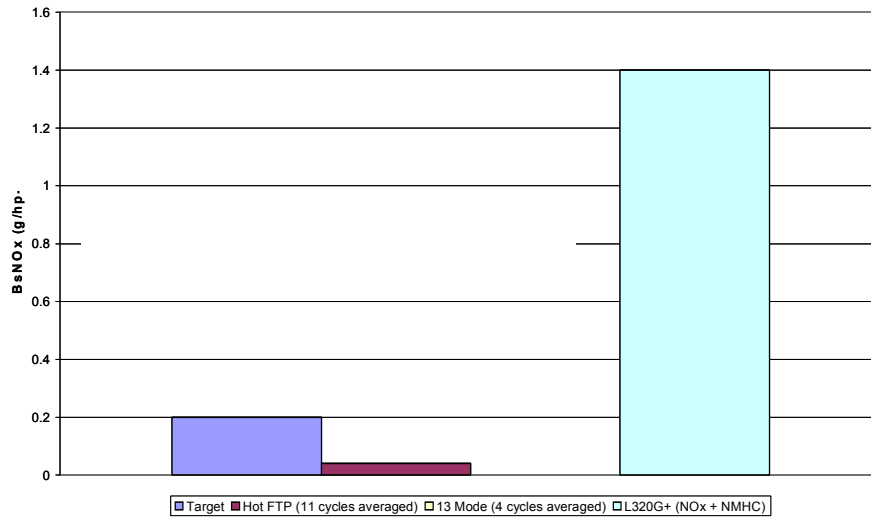

Figure (5a): NOx Emissions

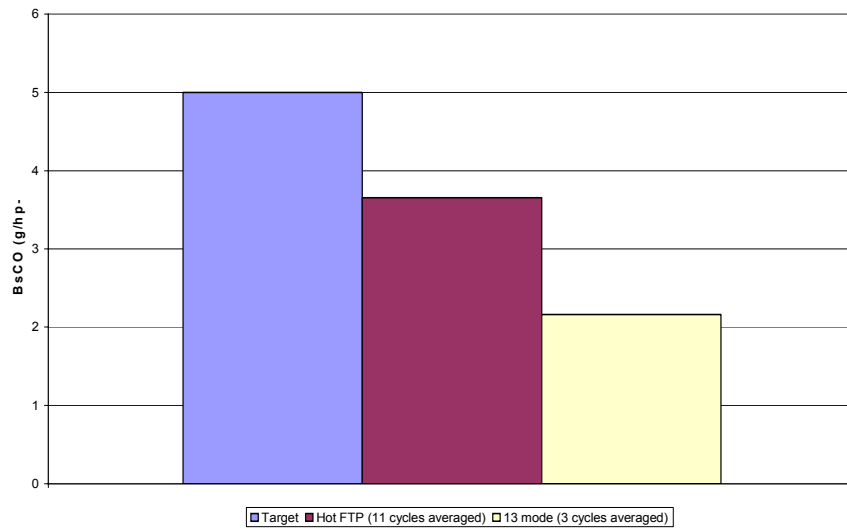

Figure (5b): CO Emissions

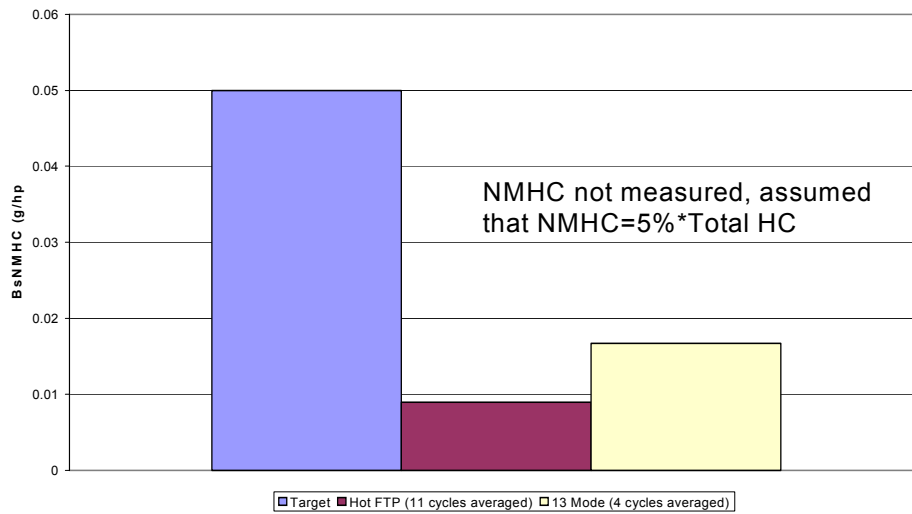

Figure (5c): NMHC Emissions

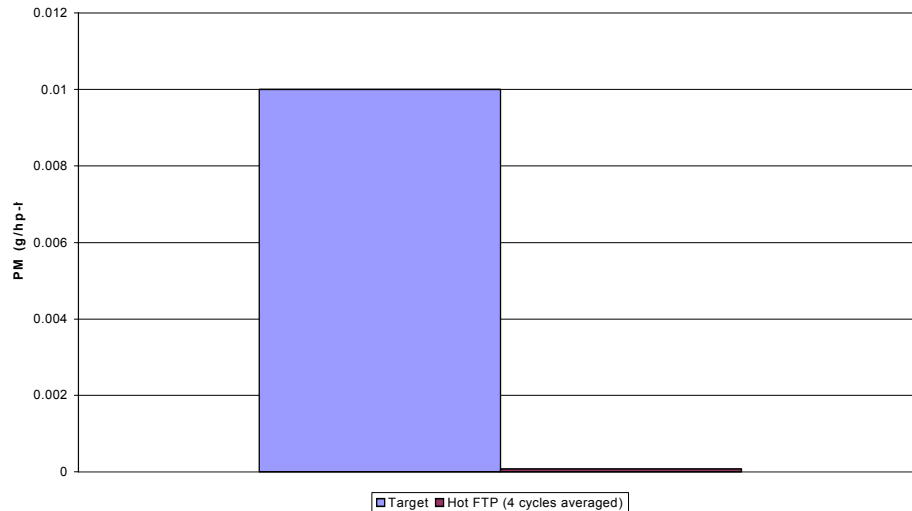

Figure (5d): PM Emissions

Task 2.2 Control System Development

This task includes the development of a new engine control module (ECM) and control system for the concept engine. The initial work on the concept engine was conducted with a test cell based controller rather than an integrated engine controller. The system was originally developed by Cummins Inc. research group and it provided the interface and systems control capability needed to operate the engine for the early stages of the concept demonstration. This test cell based system was replaced by the integrated developmental system (ECM) in March '05 when it became available. The development of the control algorithms and software was hence advanced from bench only to bench and test cell. Once the capability of the new system was demonstrated, the test cell based controller was eliminated and all engine control functions were handled by the ECM.

Figure (6) is a layout of the ECM used for the development of the control system. It is a derivative of a new engine controller under development at Cummins Inc. for diesel programs (CM2100). Hardware changes were made to accommodate the needs of the new technology being developed by this program which included circuitry for sensor and actuator hardware including:

- Oxygen sensor
- Gas flow sensor
- Knock sensor
- Throttle
- Voltage regulation



Figure (6): Layout of the new engine control unit (ECU)

Control algorithms were developed for the main components of the control system strategy as shown in Figure (7). The “Combustion Manager” is the top level of the system and it commanded the sub-managers of the system to achieve the desired engine output at the operating condition. It controlled the engine operation by responding to and controlling the following system parameters to achieve the desired performance:

- Air flow
- Fuel flow
- Lambda
- Spark timing
- EGR flow

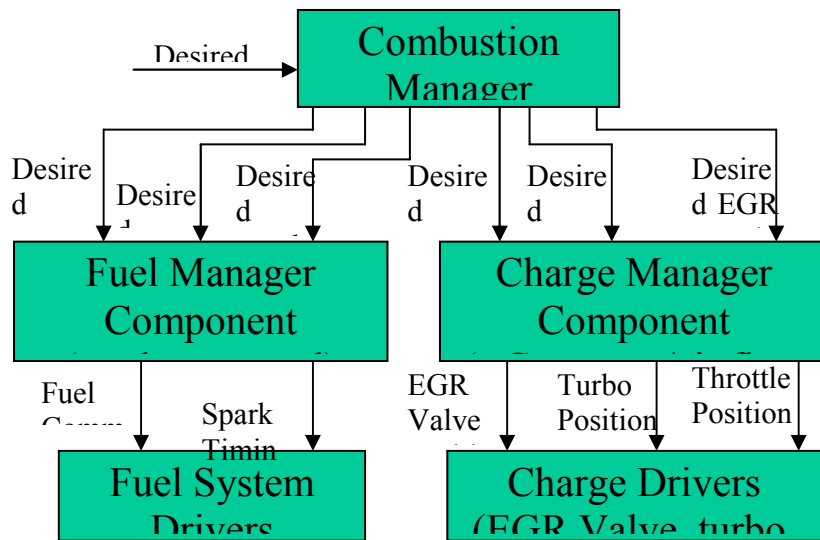

Figure (7): Overall Control System Layout

Task 2.3 Design Optimization, Structure & Release

Following the demonstration of the capability of the concept engine to achieve the target performance, optimization of the subsystems and component design was undertaken to evaluate operating margin and refine engine performance. As the capabilities of the subsystem designs are demonstrated, design stability of these components is desired. The process focused on using analysis tools to facilitate selection of most suitable component design to provide the needed performance as well as utilizing Cummins design expertise in areas such as EGR system and components. As engine subsystems and components designs were completed, design reviews were held to gain input on the design and refinements were implemented to alleviate the raised issues. Design Failure Mode and Effect Analysis were also conducted for the new components or subsystems. Structure and release of the new parts at “Development” status was also completed.

Figure (8) shows an example of analysis work conducted to arrive at a design for the Air/Fuel/EGR mixer. Through Flow analysis various design iterations were evaluated to arrive at an acceptable mixing performance as seen in the figure. The target EGR fraction on 0.2 (20%) highlighted by the arrow denotes a green color where that mixture concentration is reached. In the “First Iteration” cross section, the distribution shows large areas of “Blue” indicating fresh air and “Red” indicating unmixed EGR gases. Several iterations of the design to improve EGR distribution resulted in the final design arrangement which resulted in the improved distribution in Fig (8). Large areas of

“Green” are evident and no “Red” zones are present. Although total uniformity was not achieved at the mixer outlet considerable improvements were made from the initial design. The model also indicated that further charge mixing is achieved downstream of the mixer resulting in good cylinder to cylinder uniformity as indicated in figure (9) where very small differences are seen in the trapped EGR fraction in all six cylinders. Cylinder charge distribution of EGR fractions were predicted using computational fluid dynamics computer simulations of the engine configuration.

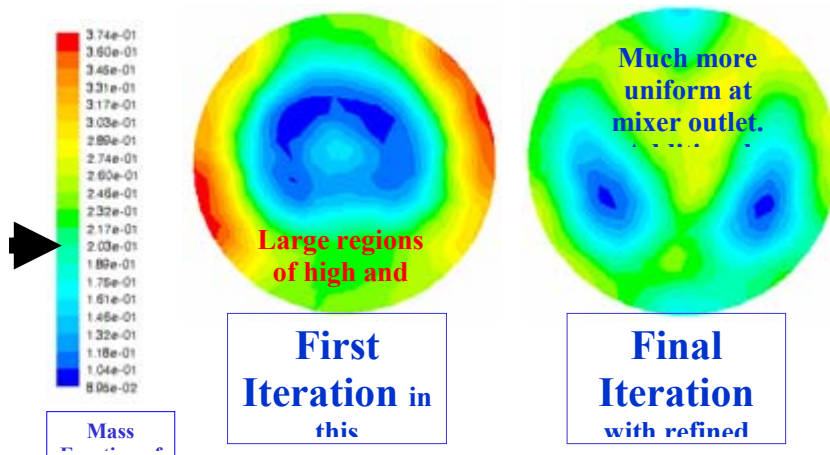

Figure (8): CFD Mixing Results

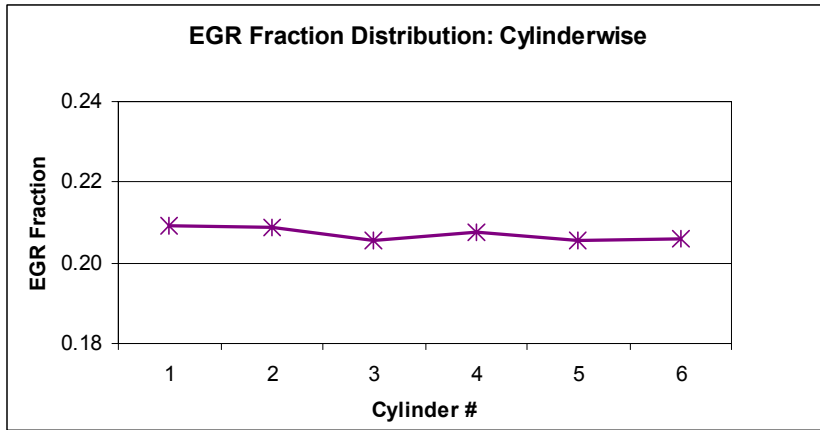

Figure (9): Cylinders distribution for the EGR Fraction

Figure (10) is a three dimensional layout drawing of the optimized design of the engine. The design is vastly different from Figure (2) which outlined the concept design of the engine. All components are fully integrated in the design as can be clearly seen.



Figure (10): Optimized Design

Design reviews were conducted per the schedule outlined in table (2) below. In addition a 'Virtual Build' which is an in depth design review with all components to build an engine in a Virtual (computer based) environment was completed at the manufacturing plant (CDC). This ensured that stable design is reached and introduced the design to all concerned functional group. Improvements were highlighted in this 'Virtual Build' which are to be addressed during the next design optimization phase.

Table (2) Design Reviews

System	Review Date
Electronics System	May 21, 05
Power Cylinder	May 31, 05
Fuel System	June 16, 05
Induction System	June 24, 05
Exhaust System	June 27, 05
CDC Virtual Build	Sept 20, 05

Task 3: Design Verification and Validation

Due to the termination of this contract, only the initial phase of this task was started and therefore only the initial elements of development are reported here.

Task 3.1: Engineering Vehicle Tests

A prototype engine was built and tested to verify performance. The engine was later installed in an Engineering truck and used for initial shake down of performance and calibration issues (Figure 11). The vehicle is a 1993 International Model 9700 Highway Tractor, 6 x 4 cab over, sleeper-body. The engine installation also included a transmission upgrade to an Allison B500 5-speed with retarder. The engine was initially built with concept hardware and later upfitted with Alpha level hardware when it became available. The truck is used to verify design changes, both hardware and software, to correct problems or to improve system and vehicle performance. The vehicle is very useful in evaluating and optimizing calibration and provided a way of rapidly checking the impact on vehicle performance.



Figure (11): Engineering Truck

Task 3.2: Alpha Engine Builds

Parts were procured and received for the build of the field test engines and arrangements were made to secure agreements with the selected field test customers. Table (3) outlines the field test plans and the delivery dates for the engines. The field test applications covered the intended market segments of transit bus and waste truck operators. These are the identified applications which traditionally used or are expected to use natural gas engines.

Two engines were also built to be used for the mechanical development of the engine subsystems. The installation and commissioning of these vehicles fall outside this phase 1 development of the program.

Table (3) Field Test Engines Details

Task	ESN	Customer	Build Completion Fcst/Actual	Test Completion Fcst/Actual
Field Test #1	99005922	LACMTA	24-Nov-05	2-Dec-05
Field Test #2	99005958	Pierce Transit	28-Nov-05	9-Dec-05
Field Test #3	99005957	WasteManagement	30-Nov-05	13-Dec-05
Field Test #4	99005961	DIA	30-Nov-05	11-Jan-06
Field Test #5	99005962	Valley Metro	2-Dec-05	17-Jan-06
Field Test #6	99005960	LAGeneral	2-Dec-05	23-Jan-06

Conclusions

This phase one development of the program has demonstrated that the target engine power output can be achieved with sufficient operating margin. The cooled EGR in combination with a 3-way catalyst was shown to also be capable of meeting the 2010 emissions standards. An integrated design with the required subsystems and components was initiated in this phase but not completed. A control system with a new controller was initiated but not completed but was able to sufficiently control the engine to facilitate the development work. Field test engines were built, tested and shipped but not installed in vehicles prior to conclusion of this contract. CWI is continuing the ISL G engine development and commercialization program with funding assistance from additional sources. ISL G commercialization is scheduled for early 2007.

REPORT DOCUMENTATION PAGE

Form Approved
OMB No. 0704-0188

The public reporting burden for this collection of information is estimated to average 1 hour per response, including the time for reviewing instructions, searching existing data sources, gathering and maintaining the data needed, and completing and reviewing the collection of information. Send comments regarding this burden estimate or any other aspect of this collection of information, including suggestions for reducing the burden, to Department of Defense, Executive Services and Communications Directorate (0704-0188). Respondents should be aware that notwithstanding any other provision of law, no person shall be subject to any penalty for failing to comply with a collection of information if it does not display a currently valid OMB control number.

PLEASE DO NOT RETURN YOUR FORM TO THE ABOVE ORGANIZATION.

1. REPORT DATE (DD-MM-YYYY) October 2006		2. REPORT TYPE Subcontract Report		3. DATES COVERED (From - To) 02/02/05 - 7/31/06	
4. TITLE AND SUBTITLE Development of a Cummins Westport SI-EGR Natural Gas Engine at 0.2 g/bhp-hr NOx: February 2, 2005 – July 31, 2006			5a. CONTRACT NUMBER DE-AC36-99-GO10337		
			5b. GRANT NUMBER		
			5c. PROGRAM ELEMENT NUMBER		
6. AUTHOR(S) M. Kamel			5d. PROJECT NUMBER NREL/SR-540-40757		
			5e. TASK NUMBER WO14.1000		
			5f. WORK UNIT NUMBER		
7. PERFORMING ORGANIZATION NAME(S) AND ADDRESS(ES) Cummins Westport, Inc. 101-1750 West 75 th Avenue Vancouver, BC V6P6G2				8. PERFORMING ORGANIZATION REPORT NUMBER ZCI-5-44118-01	
9. SPONSORING/MONITORING AGENCY NAME(S) AND ADDRESS(ES) National Renewable Energy Laboratory 1617 Cole Blvd. Golden, CO 80401-3393				10. SPONSOR/MONITOR'S ACRONYM(S) NREL	
				11. SPONSORING/MONITORING AGENCY REPORT NUMBER NREL/SR-540-40757	
12. DISTRIBUTION AVAILABILITY STATEMENT National Technical Information Service U.S. Department of Commerce 5285 Port Royal Road Springfield, VA 22161					
13. SUPPLEMENTARY NOTES NREL Technical Monitor: Aaron Williams					
14. ABSTRACT (Maximum 200 Words) The report discusses a program to develop and demonstrate advanced technologies and methods for controlling exhaust emissions in a medium-duty natural gas engine to meet 2010 federal emissions standards.					
15. SUBJECT TERMS natural gas engines; vehicle emissions; federal emission standards; exhaust emissions; medium-duty vehicles					
16. SECURITY CLASSIFICATION OF:			17. LIMITATION OF ABSTRACT UL	18. NUMBER OF PAGES	19a. NAME OF RESPONSIBLE PERSON
a. REPORT Unclassified	b. ABSTRACT Unclassified	c. THIS PAGE Unclassified			19b. TELEPHONE NUMBER (Include area code)

Standard Form 298 (Rev. 8/98)
Prescribed by ANSI Std. Z39.18