

# **Wales, Alaska High-Penetration Wind-Diesel Hybrid Power System**

## **Theory of Operation**

S. Drouilhet and M. Shirazi



**NREL**

**National Renewable Energy Laboratory**

1617 Cole Boulevard  
Golden, Colorado 80401-3393

NREL is a U.S. Department of Energy Laboratory  
Operated by Midwest Research Institute • Battelle • Bechtel

Contract No. DE-AC36-99-GO10337

# **Wales, Alaska High-Penetration Wind-Diesel Hybrid Power System**

## **Theory of Operation**

S. Drouilhet and M. Shirazi

Prepared under Task No. WER2.1750



**NREL**

**National Renewable Energy Laboratory**

1617 Cole Boulevard  
Golden, Colorado 80401-3393

NREL is a U.S. Department of Energy Laboratory  
Operated by Midwest Research Institute • Battelle • Bechtel

Contract No. DE-AC36-99-GO10337

## NOTICE

This report was prepared as an account of work sponsored by an agency of the United States government. Neither the United States government nor any agency thereof, nor any of their employees, makes any warranty, express or implied, or assumes any legal liability or responsibility for the accuracy, completeness, or usefulness of any information, apparatus, product, or process disclosed, or represents that its use would not infringe privately owned rights. Reference herein to any specific commercial product, process, or service by trade name, trademark, manufacturer, or otherwise does not necessarily constitute or imply its endorsement, recommendation, or favoring by the United States government or any agency thereof. The views and opinions of authors expressed herein do not necessarily state or reflect those of the United States government or any agency thereof.

Available electronically at <http://www.osti.gov/bridge>

Available for a processing fee to U.S. Department of Energy  
and its contractors, in paper, from:

U.S. Department of Energy  
Office of Scientific and Technical Information  
P.O. Box 62  
Oak Ridge, TN 37831-0062  
phone: 865.576.8401  
fax: 865.576.5728  
email: [reports@adonis.osti.gov](mailto:reports@adonis.osti.gov)

Available for sale to the public, in paper, from:

U.S. Department of Commerce  
National Technical Information Service  
5285 Port Royal Road  
Springfield, VA 22161  
phone: 800.553.6847  
fax: 703.605.6900  
email: [orders@ntis.fedworld.gov](mailto:orders@ntis.fedworld.gov)  
online ordering: <http://www.ntis.gov/ordering.htm>



## **About this Document**

This document represents the first chapter in the Operations and Maintenance Manual for the Wales Wind-Diesel Hybrid Power System. The entire manual is organized into many chapters with multiple appendices, totaling hundreds of pages, most of which are quite specific to the Wales system and not of general interest. The entire manual will therefore be produced in only a limited number of copies for those individuals and organizations with a direct role in operating and maintaining the system. The first chapter of the manual, however, deals with the system theory of operation, which is of more general interest, and is being published as this National Renewable Energy Laboratory (NREL) Technical Report. This report will also serve as a record, in summary fashion, of the hardware and software hybrid system controls technology developed by NREL under the Wales project. The authors intend that it be used as a reference not only by those directly involved in the operation of the Wales system, but by anyone with an interest in high-penetration, wind-diesel hybrid technology.

## TABLE OF CONTENTS

<b><u>INTRODUCTION</u></b> .....	<b>1</b>
<b><u>1 SYSTEM OVERVIEW</u></b> .....	<b>2</b>
<b><u>2 SYSTEM OPERATING MODES</u></b> .....	<b>9</b>
<b><u>3 SYSTEM OPERATING STATES</u></b> .....	<b>13</b>
<b><u>4 COMPONENT DISPATCH</u></b> .....	<b>15</b>
<b><u>4.1 Diesel Dispatch</u></b> .....	<b>15</b>
4.1.1 <i>Determining Diesel Capacity Required</i> .....	16
4.1.2 <i>Diesel Combination Selection (Diesel Run Select)</i> .....	27
<b><u>4.2 Wind Turbine Dispatch</u></b> .....	<b>29</b>
4.2.1 <i>Determining Wind Turbine Capacity Allowed</i> .....	29
4.2.2 <i>Wind Turbine Run Select</i> .....	35
<b><u>4.3 AC Machine Dispatch</u></b> .....	<b>35</b>
4.3.1 <i>Statistical AC Machine Dispatch</i> .....	36
4.3.2 <i>Instantaneous AC Machine Dispatch</i> .....	38
<b><u>4.4 DC Machine Dispatch</u></b> .....	<b>38</b>
<b><u>4.5 Auxiliary Battery Charger Dispatch</u></b> .....	<b>39</b>
4.5.1 <i>Statistical Boost Charge Dispatch Criteria</i> .....	40
4.5.2 <i>Instantaneous Boost Charge Dispatch Criteria</i> .....	40
<b><u>5 POWER FLOW MANAGEMENT</u></b> .....	<b>42</b>
<b><u>5.1 Frequency Regulation</u></b> .....	<b>42</b>
<b><u>5.2 Voltage Regulation</u></b> .....	<b>43</b>
<b><u>5.3 The Power Flow Management Algorithm</u></b> .....	<b>43</b>
5.3.1 <i>Diesel ON State</i> .....	44
5.3.2 <i>Diesel OFF State</i> .....	44
5.3.3 <i>Other System State Variables</i> .....	45
5.3.4 <i>Power Flow Management Algorithm Flowchart</i> .....	46
<b><u>6 DIESEL LOAD CONTROL</u></b> .....	<b>48</b>
<b><u>6.1 The Diesel Load Set Point</u></b> .....	<b>48</b>

<b><u>6.2</u></b>	<b><u>Diesel Load Control Modes</u></b>	<b>49</b>
<b><u>7</u></b>	<b><u>NONDIESEL POWER COMPONENT CONTROL</u></b>	<b>50</b>
<b><u>7.1</u></b>	<b><u>Dump Load Control</u></b>	<b>50</b>
7.1.1	<i>Determining Dump Load Required: Dump Load Control Modes</i>	50
7.1.2	<i>Local/Remote Dump Load Apportionment</i>	51
7.1.3	<i>Dump Load Element Switching</i>	53
<b><u>7.2</u></b>	<b><u>AC Machine Control</u></b>	<b>54</b>
7.2.1	<i>AC Machine Startup Sequence</i>	54
7.2.2	<i>On-Line Control Modes of the AC Machine</i>	55
7.2.3	<i>AC Machine Shutdown Sequence</i>	55
<b><u>7.3</u></b>	<b><u>DC Machine Control</u></b>	<b>56</b>
7.3.1	<i>DC Machine Startup Sequence</i>	57
7.3.2	<i>On-Line Control Modes of the DC Machine</i>	57
7.3.3	<i>DC Machine Shutdown Sequence</i>	58
<b><u>8</u></b>	<b><u>BATTERY MANAGEMENT</u></b>	<b>59</b>
<b><u>8.1</u></b>	<b><u>Battery Characteristics</u></b>	<b>59</b>
<b><u>8.2</u></b>	<b><u>State of Charge Tracking</u></b>	<b>61</b>
<b><u>8.3</u></b>	<b><u>Battery Status Flags</u></b>	<b>62</b>
<b><u>8.4</u></b>	<b><u>Normal Charging and Discharging</u></b>	<b>64</b>
<b><u>8.5</u></b>	<b><u>Boost Charging</u></b>	<b>65</b>
<b><u>9</u></b>	<b><u>FAULT DETECTION AND HANDLING</u></b>	<b>66</b>
<b><u>10</u></b>	<b><u>DATA LOGGING AND REPORTING</u></b>	<b>68</b>
<b><u>10.1</u></b>	<b><u>Data Acquisition, Logging, and Transfer</u></b>	<b>68</b>
<b><u>10.2</u></b>	<b><u>Data Decoding</u></b>	<b>69</b>
<b><u>10.3</u></b>	<b><u>Data Analysis and Reporting</u></b>	<b>70</b>

## Introduction

Alaska has over 200 rural villages that have no link to the power grids serving the main urban areas. The majority of these villages are served by diesel-driven generators. Because of the extreme remoteness of most of these communities, and the lack of roads, the delivered cost of diesel fuel is high, ranging from \$1.00 to \$3.00 per gallon. The high operating and maintenance costs of diesel generating stations result in electric generation costs that average nearly \$0.40/kWh and can be as high as \$1.00/kWh. There are also significant environmental hazards associated with diesel power generation, including fuel spills during transport, leaky bulk fuel tanks in the villages, and carbon dioxide (CO<sub>2</sub>) and other emissions.

To reduce the cost of rural power generation and the environmental impact of diesel fuel usage, the Alaska Energy Authority (AEA), Kotzebue Electric Association (KEA, a rural Alaskan utility), and the National Renewable Energy Laboratory (NREL), began a collaboration in late 1995 to implement a high-penetration wind-diesel hybrid power system in a village in northwest Alaska. The project was intended to be both a technology demonstration and a pilot for commercial replication of the system in other Alaskan villages. Significant financial contributors to the project were the U.S. Environmental Protection Agency (EPA), the U.S. Department of Energy (DOE), and the Alaska Science and Technology Foundation. Kotzebue Electric Association and the Alaska Village Electric Cooperative also contributed some of their own resources to bring the project to fruition.

During the first several years of the project, NREL focused on the design and development of the electronic controls, the system control software, and the ancillary components (power converters, energy storage, electric dump loads, communications links, etc.) that would be required to integrate new wind turbines with the existing diesels in a reliable highly automated system. Meanwhile, AEA and KEA focused on project development activities, including wind resource assessment, site selection and permitting, community relationship building, and logistical planning. Ultimately, the village of Wales, Alaska, was chosen as the project site. Wales is a native Inupiat village of approximately 160 inhabitants, with an average electric load of about 75 kW.

A variety of obstacles, both technical and project development related, were encountered in the years 1996-1999, delaying the installation and commissioning of the system several years beyond the date originally projected. Testing and demonstration of proper operation of the wind-diesel control system was completed at NREL's National Wind Technology Center (NWTC) in spring of 2000. The wind turbines, control panels, and ancillary components were installed in Wales in summer of 2000. The hybrid power system began operation in fall of 2000, with successful demonstration of all operating modes not occurring until fall of 2001.

## 1 System Overview

The Wales Wind-Diesel Hybrid Power System combines diesel generator sets, wind turbines, energy storage, power converters, and various control components into a single highly integrated system. The primary purpose of the system is to meet the village electric demand with high-quality power, while minimizing diesel fuel consumption and diesel engine run time. The system also directs excess wind power to several thermal loads in the village, thereby saving heating fuel as well as diesel fuel for electric generation.

Figure 1 is a one-line diagram of the system showing the principal power components, which are itemized in Table 1. Although there are currently only two wind turbines installed, the figure shows three because a third turbine one is planned. Figure 2 shows the components and interconnections of the controls that govern the operation of the entire wind-diesel system.

**Table 1. Roster of Power Components in the Wales Wind-Diesel System**

Qty	Component	Rating	Make & Model
2	Wind Turbine	65 kW	Atlantic Orient Corp. 15/50
1	Diesel Generator	168 kW	Cummins LTA10
1	Diesel Generator	75 kW	Allis-Chalmers 3500
1	Diesel Generator	168 kW	Cummins LTA10
1	Local Dump Load Controller	89 kW	NREL Design
1	Remote Dump Load Controller	144 kW	NREL Design
1	Rotary Converter	156 kVA	NREL Design (AC Machine: Kato Engineering) (DC Machine: Reliance Electric)
200	Battery Cell	1.2 VDC 130 Ah	SAFT SPH130, Nickel Cadmium
1	Auxiliary Battery Charger	300 VDC 30 A	NREL Design

The Atlantic Orient (AOC) wind turbines use 480 volt 3-phase induction generators and connect directly to the medium voltage village distribution system through step-up transformers. The diesel generators are of the synchronous type, also 480 volt 3-phase. The dump load controllers each consist of a computer-controlled bank of solid-state relays, each of which controls power flow to a 480 volt 3-phase heating element in an electric boiler. The relays may be switched on and off rapidly, thereby providing precise real time control over electric power to the dump loads.

The rotary converter is an electromechanical bidirectional AC/DC power converter. It consists of an AC synchronous generator shaft coupled to a DC motor. When in use, the AC machine is connected to the 480 VAC bus of the power plant. When the DC machine is in use, it is



connected to the battery bank. As will be explained later in detail, by controlling the field current in the AC and DC machines, one can control the flow of both real (kW) and reactive (kVAR) power between the AC bus and the rotary converter. Being shaft-coupled, the DC machine always spins at the same speed as the AC machine. Electrically, however, the AC machine can operate independently from the DC machine. The AC machine can on-line (connected to the AC bus) without the DC machine being on-line (connected to the battery bank). In this state, the rotary converter is operating simply as a synchronous condenser. There is no equivalent operating state involving only the DC machine, which cannot be on-line unless the AC machine is also on-line.

Though not shown in Figure 1, there is also a small 10 HP pony motor used to spin the rotary converter up from rest to synchronous speed so that the AC machine may be connected to the AC bus. The pony motor is connected to the AC machine by a large timing belt.

How these components interact to provide continuous high-quality power is explained in the various chapters of this report. If the reader is unfamiliar with concepts of real and reactive power and the basic methods of frequency and voltage control, it may be helpful to first read Chapter 5 on power flow management before Chapter 4 on component dispatch.

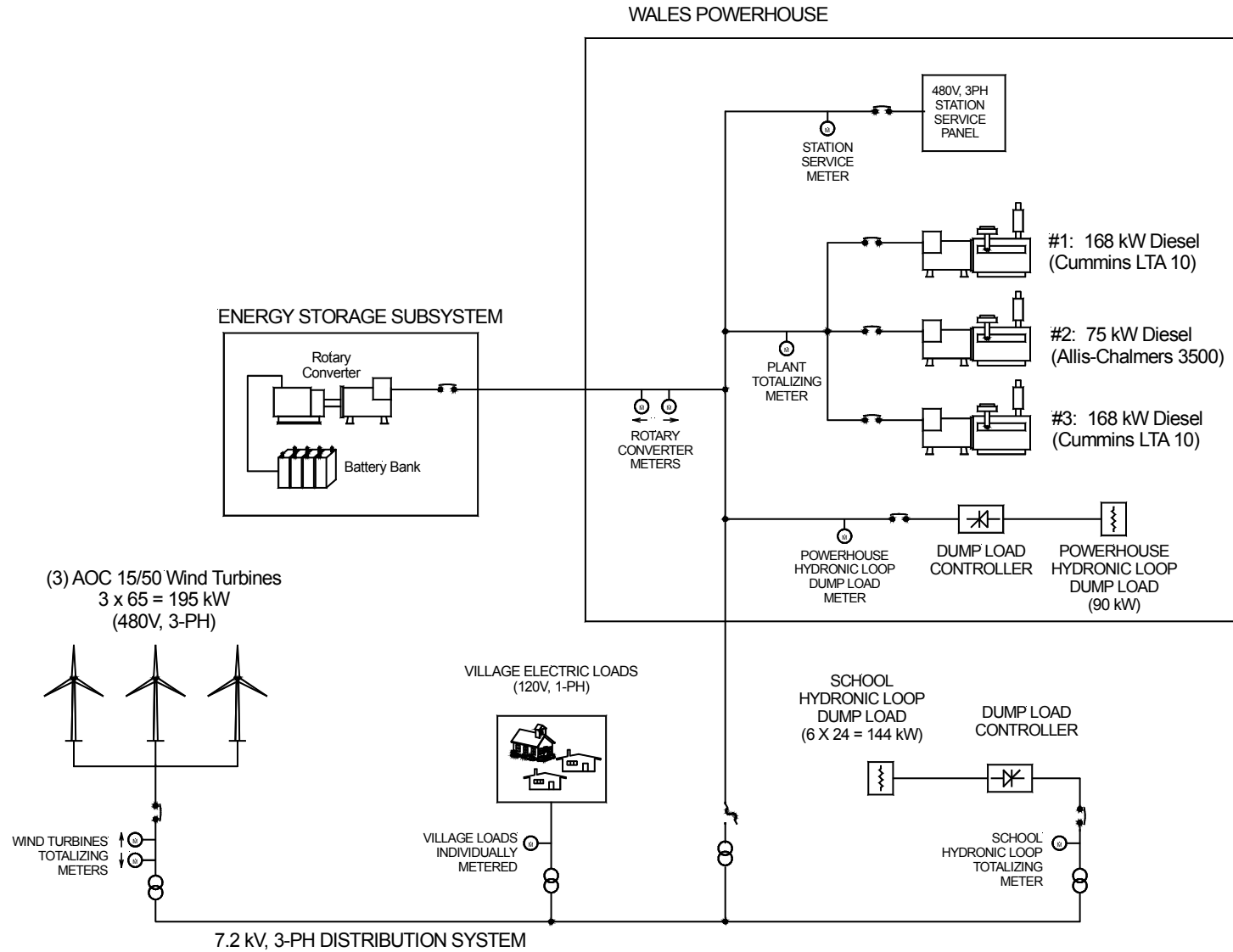

**Figure 1. Wales wind-diesel hybrid power system**

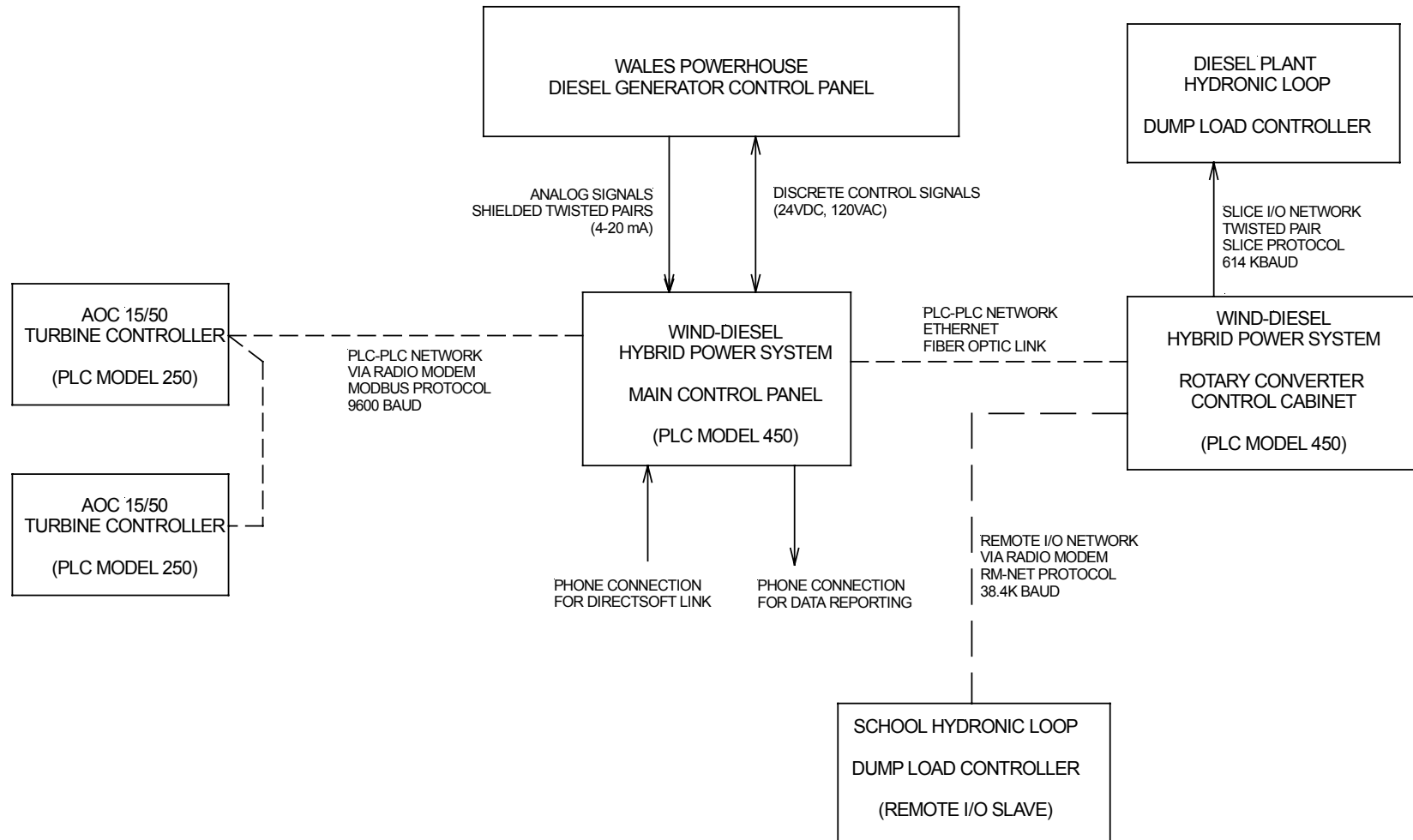

**Figure 2. Wind-Diesel system control layout**

## 2 System Operating Modes

There are five possible system operating modes: Manual, Mode 0, Mode 1, Mode 2, and Mode 3. Each of these modes implies the availability of a particular set of power system components. The current operating mode says nothing about the actual operating state of the systems (i.e., which components are actually on-line), only which components could be on-line. The various operating modes and their characteristics are summarized in Table 2.

Once the system operator places the system in a particular mode, it will remain in that mode until the operator requests a different operating mode, or until a required component becomes unavailable. In that case, the control system will automatically drop down to the next lowest operating mode that does not require that component.

Structuring the control system in terms of distinct operating modes based on component availability makes the controller more robust and fault tolerant. Mode 3 is the normal and intended operating mode for the system. This mode requires the availability of all system components. Suppose there were a fault in the battery bank or DC machine, making the energy storage function unavailable. In that case, if there were a single rigid system control algorithm that assumed the availability of energy storage, then the entire automatic control system could not function, and the power system would be reduced to manual diesel operation until the fault was repaired. With the distinct operating modes, however, the system would simply drop into Mode 2 and continue to function, now as a no-storage wind-diesel system. Thus, the failure of a particular component does not necessarily render the system inoperative.

Note that the system is intended to be operated from the Wind-Diesel Control Panel, which is the plant supervisory controller. Even in Manual Mode, the diesel start/stop commands are issued from the Wind-Diesel Control Panel, and the diesel automatic synchronization and load-sharing remains fully functional.

**Table 2. Wales Wind-Diesel System Operating Modes**

MODE	DESCRIPTION	AUTO DISPATCH	DIESEL GENSET	WTG	DUMP LOADS	AC MACH.	DC MACH.	BATT. BANK
MANUAL	Diesel genset mode. Diesels dispatched manually from operator interface. System defaults to this mode when bus de-energized.		X					
0	Diesel genset mode. At least one diesel runs continuously. No wind turbines available. Diesel gensets dispatched automatically to meet load.	X	X					
1	At least one diesel always running. Wind turbines run whenever wind is available. Diesel genset controls system frequency and voltage. Dump load ensures minimum load on diesel.	X	X	X	X			
2	Diesel runs only if wind turbines cannot meet the load with adequate margin. When diesel is ON, diesel genset controls system frequency and voltage, and dump load ensures minimum average load on diesel. If not needed for reactive power, AC machine turned off to eliminate parasitic loss.  When diesel is OFF, AC machine controls system voltage, dump load controls system frequency.	X	X	X	X	X		
3	Same as Mode 2, except:  When diesel is ON, excess diesel power is used to charge battery. If load briefly exceeds wind power plus on-line diesel capacity, power is drawn from battery as needed to prevent another diesel from coming on. The diesel genset controls system voltage and frequency.  When diesel is OFF, excess wind power is first used to charge the battery. Additional excess power is sent to the dump load. If wind power is briefly insufficient to meet the load, power is drawn from the battery as necessary to keep a diesel from being turned on. The AC machine controls system voltage. The DC machine controls system frequency, unless dump load is required, in which case dump load controls frequency.	X	X	X	X	X	X	X

### 3 System Operating States

The *system operating state* refers to the set of power sources that are actually on-line at any given time. 10 different operating states are possible, as shown in Table 3. The integer state designations refer to the various possible combinations of *real* power sources. Note that the AC machine by itself (without the DC machine) is not considered a real power source. Thus, both States 1A and 1B refer to the situation where diesel is the only generating source on-line. In State 1B, the AC machine is acting only as a synchronous condenser. State 2, in which both the diesel(s) and the wind turbine(s) are on-line, is similarly divided into States 2A and 2B, depending on whether or not the AC machine is on-line. Certain combinations of components are not possible and therefore do not have state designations. For example, the DC machine cannot be on-line unless the AC machine is on-line, so there are not defined states where that is the case.

The system state usually is not something that the operator need be concerned with. System state information is used internally by the system controller to determine which set of component dispatch algorithms to use at any given time.

**Table 3. Definition of System Operating States**

STATE	COMPONENT STATUS				FREQUENCY CONTROL
	DIESEL	WTG	AC MACHINE	BATTERY AND DC MACHINE	
0					(system de-energized)
1A	X				diesel
1B	X		X		diesel
2A	X	X			diesel
2B	X	X	X		diesel
3		X	X		dump load
4	X		X	X	diesel
5	X	X	X	X	diesel
6		X	X	X	battery
7			X	X	battery

Only certain states are possible in each of the system operating modes, based on component availability. Table 4 indicates the possible operating states in each of the various system operating modes.



## 4 Component Dispatch

*Note to the reader:* In this chapter, capital letters are used to refer to Algorithms or Procedures in the control program. Italics are used to refer to *Parameters or Quantities* used by the algorithms, and underlining is used for emphasis or when introducing new terms.

Component Dispatch refers to the process of determining when to turn on/off individual diesel generators, individual wind turbines, the AC machine, the DC machine, and the auxiliary battery charger. This is distinct from Component Control, which refers to the process of actually starting/stopping each component and bringing it on-line/taking it off-line.

The dispatch process depends on whether there is only one unit in a particular component group or multiple units. For single-unit component groups, such as the AC machine, DC machine, and battery charger, dispatch is only a matter of determining when to turn the component on and when to turn it off. For multiple-unit groups, such as the diesels and wind turbines, dispatch consists of two phases: first, determining the quantity, in terms of kW capacity, of that component required or allowed to be on-line at any given moment, and second, determining which of the individual units to turn on/off to meet that quantity.

Two different types of criteria are used to make the determinations shown above for single-unit component dispatch and the first phase of multiple-unit component dispatch: statistical and instantaneous. Statistical dispatch criteria serve as the foundation of component dispatch. The objective of statistical dispatch criteria is to predict wind power generation and electric load in the near future, based on the recent past, and to turn components on/off in response to any predicted imbalances. Statistical dispatch criteria are evaluated once every minute or in response to special events that indicate an imminent loss of a system component.

Instantaneous dispatch criteria serve as a backup to statistical dispatch criteria. The objective of instantaneous dispatch criteria is to monitor instantaneous power values and to immediately turn components on/off to prevent sudden and unexpected system power imbalances. Instantaneous dispatch criteria are evaluated every scan of the programmable logic controller (PLC) program, or approximately 20 times per second.

The following sections describe both the instantaneous and statistical dispatch criteria for each of the components in further detail. In addition, for diesels and wind turbines, these sections also describe the methods used to determine which individual generators/wind turbines to turn on/off to meet capacity requirements (the second phase of multiple-unit component dispatch).

### 4.1 Diesel Dispatch

Because the diesel generators are a multiple-unit component group, Diesel Dispatch consists of two phases:

1. Determining diesel generating capacity required to be on-line at any given moment



2. Determining the optimal combination of diesel generators to supply the required capacity (this process is called Diesel Run Select)

Diesel Dispatch is thus distinct from Diesel Control, which is the process of turning on/off actual control signals to start/stop, synchronize, and load/unload a generator and to close/open the generator breaker.

Diesel Dispatch is enabled if the system is operating in Auto Mode 0, 1, 2, or 3. It is disabled if the system is operating in Manual Mode.

The following sections describe the two phases of Diesel Dispatch.

#### **4.1.1 Determining Diesel Capacity Required**

*Diesel Capacity Required* is defined as the minimum amount of diesel capacity that must be on-line to ensure that the primary load is always met. This amount depends on the primary load on the bus (the load that must be met) and the power available from all other sources. *Diesel Capacity Required* may be significantly greater than the instantaneous load on the diesels at any given instant. Load and wind power fluctuations, combined with the fact that diesel capacity cannot be added instantaneously, require that a certain reserve capacity be maintained. At any instant, the wind power could drop, increasing the load that must be met by the diesels. Without any reserve capacity, this would result in a power outage because another diesel could not be started and brought on-line instantaneously.

Diesel Dispatch is based on both statistical and instantaneous dispatch criteria. Statistical dispatch criteria can increase or decrease *Diesel Capacity Required* in order to start or stop a diesel. Instantaneous dispatch criteria can only increase *Diesel Capacity Required* to immediately start a diesel if there is insufficient power available on the bus to supply the load.

##### **4.1.1.1 Statistical Diesel Dispatch**

The objective of Statistical Diesel Dispatch is to predict that portion of the primary load that must be met by the diesels in the near future. Statistical diesel dispatch criteria are evaluated every minute or in response to special events that indicate an imminent loss of a system component(s), e.g., the occurrence of system warnings, component warnings, component disable requests, and/or mode change requests.

Statistical Diesel Dispatch consists of the following steps:

1. Determining the appropriate statistical diesel dispatch mode
2. Evaluating the corresponding criteria to determine *Diesel Capacity Required*
3. Determining whether or not all diesels may be shut off
4. Evaluating any additional special dispatch considerations and determining whether or not to execute Diesel Run Select.

The following sections describe these steps.

#### 4.1.1.1.1 Statistical Diesel Dispatch Modes

The first step in Statistical Diesel Dispatch is to determine the appropriate dispatch mode based on the system state as defined in Section 3. The system state is the combination of power sources on-line at any given moment. There are four different sources of real and/or reactive power:

1. Diesels
2. Wind turbines
3. AC machine
4. Battery bank/DC machine.

In many cases, the system controller will have advanced notice that a generating component will soon go off-line. For example, a component warning, a component disable request, or mode change request all may indicate the imminent (but not immediate) loss of a component, possibly changing the system operating state. *Diesel Capacity Required* will increase when a power source component goes off-line. To prevent possible loss of load when a component goes off-line, Statistical Diesel Dispatch must determine *Diesel Capacity Required* based on the projected system state rather than the current system state. The projected system state is the combination of power sources expected to be on-line in the near future. There are statistical diesel dispatch modes corresponding to each projected system state, with a separate set of dispatch criteria for each mode, to handle the various possible projected states. Statistical Diesel Dispatch will determine the appropriate statistical diesel dispatch mode and evaluate the corresponding criteria once every minute, or whenever conditions indicate a system component(s) is about to be taken off-line, e.g., the occurrence of system warnings, component warnings, component disable requests, and/or mode change requests. There are six statistical diesel dispatch modes:

- Statistical Diesel Dispatch projected state 1A Mode
- Statistical Diesel Dispatch projected state 1B Mode
- Statistical Diesel Dispatch projected state 2A Mode
- Statistical Diesel Dispatch projected state 2B or State 3 Mode
- Statistical Diesel Dispatch projected state 4 or State 7 Mode
- Statistical Diesel Dispatch projected state 5 or State 6 Mode.

Note that several statistical dispatch modes apply to more than one projected state. That is because the criteria used to evaluate required diesel capacity are driven by the non-diesel generating components on-line. For example, the same dispatch mode is used for projected states 4 and 7, which both have wind turbine(s) and the battery on-line.

#### 4.1.1.1.2 Statistical Diesel Dispatch Criteria

Once Statistical Diesel Dispatch has determined the appropriate dispatch mode, the next step is to evaluate the corresponding dispatch criteria to determine *Diesel Capacity Required*. There are four criteria corresponding to each statistical diesel dispatch mode. Each criterion quantifies a different dispatch criterion for *Diesel Capacity Required*: average kW, peak kW, average kilovolt ampere reactive (kVAR), and peak instantaneous kW. The actual *Diesel Capacity Required* value used to determine which diesels to turn on/off will be the largest of the *Diesel Capacity Required* values predicted by each of the four criteria. The *Diesel Capacity Required* given by some or all of the criteria may be negative, which simply means that according to those criteria, no diesel capacity is required. If *Diesel Capacity Required* is less than zero according to all criteria, and certain other conditions are met, the system may switch to (or remain in) diesel-off operation.

Note: In the following sections we use the term primary kW load to distinguish this load from the secondary kW load. The primary kW load consists of those kW loads that must always be met, whereas the secondary kW load consists of those loads that can be turned on/off at any time and therefore need only be met when there is excess wind power. The primary kW load always includes the village kW load. It also includes the kW required to spin the rotary converter if the AC machine is on-line and kW required to boost charge if the system is boost charging. The secondary kW load consists of local and remote dump load and rotary converter DC kW.

We do not make the same distinction for the total kVAR load. This is because the entire kVAR load must always be met – there are no kVAR loads that can be turned on/off at any time. The kVAR load consists of the village kVAR load plus the kVAR consumed by the wind turbines' induction generators.

#### Statistical Diesel Dispatch Average kW Criterion

The objective of the statistical diesel dispatch average kW criterion is to dispatch sufficient diesel capacity to ensure that the average near-future primary kW load can be met without exceeding a user-specified percentage of the diesel capacity on-line, called the *Maximum Allowed Continuous % Diesel Loading*.

Predicting the average kW load that must be supplied by the diesels requires predicting the average future village kW load and average future wind power. Although not perfect, the recent past is the best available predictor of the future. The average kW criterion uses the most recent 20-minute average values of village kW load and wind power to determine the expected average primary kW load and expected average wind power.

The following is an example of a statistical diesel dispatch average kW criterion. It is the criterion that applies to projected states 5 (Diesel + Wind + Battery) and 6 (Wind + Battery).

$$\text{Diesel Capacity Required} = \frac{(\text{Village kW 20m Average} + \text{kW to Spin Rotary Converter}) - \text{Wind kW 20m Average}}{\text{Maximum Allowed Continuous \% Diesel Loading}}$$

Note that diesel capacity is dispatched to meet the entire difference between expected average load and wind power, regardless of whether the projected state includes the battery bank or not. This is because the batteries are not intended to supply the average load. As described in the following section, they are only intended to meet short-term power requirements caused by fluctuations in wind power.

#### Statistical Diesel Dispatch Peak kW Criterion

The objective of the statistical diesel dispatch peak kW criterion is to dispatch sufficient diesel capacity to ensure that the peak near-future primary kW load can be met without exceeding the diesel capacity on-line.

This requires predicting the maximum kW load that must be supplied by the diesels in the near future. This amount depends on whether or not the projected state includes the wind turbines and the battery bank. Wind power can be used to supply the peak primary kW load. In addition, if the batteries are on-line, then the batteries can also be discharged to meet the peak primary kW load. By supplying power during short-term peak loading conditions caused by transient dips in wind power, the batteries can prevent the necessity of starting another diesel. The maximum amount of AC kW power that can be delivered from the batteries through the rotary converter is called the *Rotary Converter kW Limit* and is based on either the maximum discharge rate of the battery bank or the kW capacity of the rotary converter, whichever is smaller.

Predicting the maximum kW load that must be supplied by the diesels requires predicting the maximum future village kW load and minimum future wind power. The peak kW criterion applies predictive safety factors to the most recent 20-minute maximum village kW load and minimum wind power values to determine the expected maximum primary kW load and expected minimum wind power. The predictive safety factors are included to accommodate the fact that the wind power may be dropping and the load may be rising relative to the recent past.

The following is an example of a statistical diesel dispatch peak kW criterion, the one used for projected state 5 (Diesel + Wind + Battery) and 6 (Wind + Battery):

$$\text{Diesel Capacity Required} = \text{Village kW 20m Peak} \times \text{Village kW Safety Factor} - (\text{Wind kW 20m Minimum} \times \text{Wind kW Safety Factor} + \text{Rotary Converter kW Limit})$$

Note that the rotary converter power losses (the power required to energize and spin the rotary converter) are not included in this criterion, because they are embedded in the *Rotary Converter kW Limit*. When the rotary converter is supplying power to the bus, the batteries supply the rotary converter losses.

### Statistical Diesel Dispatch kVAR Criterion

The kVAR capacity of a generator is limited by saturation and/or heating effects in the windings and therefore can be exceeded on a transient basis without harm. Thus, it is only necessary to dispatch diesel capacity to meet the average kVAR load, not the peak kVAR load. The objective of the statistical diesel dispatch kVAR criterion is to dispatch sufficient diesel capacity to ensure that the average near-future kVAR load can be met without exceeding the kVAR capacity on-line.

This requires predicting the average kVAR load that must be supplied by the diesels in the near future. This amount depends on whether or not the projected state includes the AC machine. If the AC machine is on-line, it will share VARs proportionally with the diesel generators.

Predicting the average kVAR load that must be supplied by the diesels requires predicting the average future total kVAR load. The average kVAR criterion uses the most recent 1-minute average kVAR load to determine the expected average total kVAR load. The criterion uses 1-minute averages instead of 20-minute averages in order to respond more quickly to an overload situation (because there is no peak kVAR criterion).

Once the criterion has determined the kVAR capacity required, it must then convert this into an equivalent kW capacity required value. This is because the diesel combination table used to determine which diesels to turn on/off to meet the *Diesel Capacity Required* rates each combination in terms of kW capacity only. The criterion uses two different diesel capacity ratio factors to accomplish this conversion, the *Diesel kVAR:kVA Capacity Ratio* and the *Diesel kW:kVA Capacity Ratio*.

The *Diesel kVAR:kVA Capacity Ratio* expresses the kVAR to kVA capacity ratio of the diesel generators. It is used, along with the *Diesel kW:kVA Capacity Ratio*, to convert kVAR capacity required to a kW equivalent value and to determine kVAR capacity ready from kW capacity ready. The *Diesel kVAR:kVA Capacity Ratio* should be approximately the same for all generators. Most generators are rated at 0.8 power factor. If such a generator were supplying rated kW (80% of kVA rating), the most kVAR it could supply would be 60% of kVA rating in order to remain within its kVA rating. By setting the *Diesel kVAR:kVA Capacity Ratio* to 0.6, we ensure that we will never exceed the kVA capacity of the generator as long as we do not exceed the kW capacity and calculated kVAR capacity. Therefore, there is no need for diesel dispatch to consider kVA criteria.

The *Diesel kW:kVA Capacity Ratio* expresses the kW to kVA capacity ratio of the diesel generators. It is used to convert kVA capacity required to a kW equivalent value and to determine diesel kVA capacity ready from kW capacity ready. Depending on the size of the engine relative to the size of the generator, each diesel on-site may have a different kW:kVA capacity ratio. By using the largest of these ratios for all gensets on-site, we can ensure that any given diesel combination that can provide the equivalent kW capacity required can also provide the kVA capacity required.

The following is an example of a statistical diesel dispatch kVAR criterion, the one used for projected state 5 (Diesel + Wind + Battery) or 6 (Wind + Battery):

$$\text{Diesel Capacity Required} = \frac{\text{Total kVAR Load 1m Average} - \text{Rotary Converter kVAR Capacity}}{\text{Diesel kVAR:kVA Capacity Ratio}} \times \text{Diesel kW:kVA Capacity Ratio}$$

#### Statistical Diesel Dispatch Peak Instantaneous Diesel Capacity Required Criterion

Instantaneous Diesel Dispatch will start a diesel immediately if the instantaneous power quantities used by its criteria exceed user-specified limits (see Section 4.1.1.2). To ensure that Statistical Diesel Dispatch does not turn off a diesel after Instantaneous Diesel Dispatch has just started one, the statistical diesel dispatch peak instantaneous diesel capacity required criterion prevents this from happening by ensuring that *Diesel Capacity Required* is never less than the most recent 20-minute peak instantaneous diesel capacity required. The criterion is the same regardless of the projected state.

Statistical Diesel Dispatch Peak Instantaneous Diesel Capacity Required Criterion:

$$\text{Diesel Capacity Required} = \text{Instantaneous Diesel Capacity Required 20m Peak}$$

#### **4.1.1.1.3 Statistical Diesel Dispatch Diesel-Off Criteria**

Once Statistical Diesel Dispatch has determined the appropriate dispatch mode and evaluated the corresponding dispatch criteria to determine *Diesel Capacity Required*, the next step is to determine whether or not all diesels may be shut off. There are two conditions that must be met before diesel-off operation is allowed: 1) the projected state must include wind turbines and the AC machine, and 2) there must be sufficient wind power to shut all the diesels off. The first condition is straightforward. The second condition involves a number of different considerations.

The most obvious requirement to ensure sufficient wind power to shut all the diesels off is that *Diesel Capacity Required* be less than zero. If the projected state does not include the battery bank, this implies that (1) the expected average wind power is sufficient to cover the expected average primary kW load, (2) the expected minimum wind power is sufficient to cover the expected maximum primary kW load, and (3) the rotary converter can supply the expected average kVAR load. If the projected state includes the battery bank, this implies that (1) the expected average wind power is sufficient to cover the expected average primary kW load, (2) the expected minimum wind power plus the *Rotary Converter kW Limit* is sufficient to cover the expected maximum primary kW load, and (3) the rotary converter can supply the expected average kVAR load.

*Diesel Capacity Required* being less than zero is not by itself sufficient to shut off all the diesels. There are additional requirements that must be met, one pertaining to the minimum instantaneous excess wind power, the other to the average excess wind power.

#### Statistical Diesel Dispatch Diesel-Off Minimum Excess Power Requirement

The minimum excess power requirement only applies if the projected diesel-off state does not include the battery bank. In this state, frequency control is accomplished by modulating dump load power to maintain an instantaneous real power balance. This frequency control mode requires that there is some amount of dump load on-line at all times. If, in the course of trying to regulate frequency, all dump load is removed, then controllability is lost. Any additional load on the system, or drop in wind power, will create an imbalance that cannot be corrected by further decreasing the amount of dump load. Therefore, a safety margin of excess wind power is necessary to prevent outages caused by larger-than-anticipated load fluctuations. Thus, wind-only operation (no diesel or battery) will only be allowed if the expected wind power is sufficient to cover the maximum primary load and maintain a user-specified amount of excess power, which is called the *Wind-Only Dump Load Margin*.

This is in contrast to the statistical diesel dispatch rules for states in which either a diesel or the battery bank is on-line. Even when these components reach their full power rating, some additional power is always available on a transient basis to respond to wind and load fluctuations. However, with dump load frequency control, once all dump load has been removed, no additional power is available, even on a short-term basis. It is this increased vulnerability to power fluctuations in the wind-only state that requires the excess wind power margin.

#### Statistical Diesel Dispatch Diesel-Off Average Excess Power Requirement

The statistical diesel dispatch diesel-off average kW requirement applies regardless of the projected state. The Alaska Village Electric Cooperative (AVEC) power plant in Wales relies on waste heat from the engines to keep the off-line diesel engines warm and to heat the power plant. Once the diesels are shut off, this heat must be supplied by the local dump load. Therefore, diesel-off operation will only be allowed if the expected average wind power is sufficient to cover the expected average primary kW load and maintain enough excess power to keep the diesel engines warm and heat the power plant. This amount of excess power is called *Plant Heat Required*. An empirically determined linear expression, in terms of a *Plant Heat Constant* and a *Plant Heat Loss Factor*, is used to estimate *Plant Heat Required*. Note that if the linear expression yields a value less than the user-specified *Minimum Plant Heat Required*, the latter is used instead.

$$\text{Plant Heat Required} = \text{MAXIMUM}\{\text{Minimum Plant Heat Required}, \\ \text{Plant Heat Constant} + [\text{Plant Heat Loss Factor} \times (70 - \text{Outside Temperature})]\}$$

#### 4.1.1.1.4 Statistical Diesel Dispatch Additional Considerations

Once Statistical Diesel Dispatch has determined the appropriate dispatch mode, evaluated the corresponding dispatch criteria to determine *Diesel Capacity Required*, and determined whether or not it is all right to shut all the diesels off, the last step is to evaluate any additional dispatch considerations and determine whether or not to execute Diesel Run Select. Specific system conditions existing at the time Statistical Diesel Dispatch executes may require modifications to the diesel dispatch process. It may be necessary, for example, to adjust the *Diesel Capacity Required* value determined by the main statistical diesel dispatch criteria, or to modify, delay, or prevent the execution of Diesel Run Select (defined in Section 4.1). These additional considerations are described below.

##### Imminent Loss of Non-Diesel Generation Component

Because the statistical diesel dispatch criteria are based on projected state, the *Diesel Capacity Required* value determined by these criteria will have already taken into consideration imminent loss of a system component due to the occurrence of system warnings or operator requests to disable a component. (The only exception is diesel warnings and operator requests to disable a diesel generator. These do not cause a new state to be projected.) Because power transients may occur when a component goes off-line; however, it would be risky to allow a diesel to go off-line at the same time, even if the *Diesel Capacity Required* value as determined by the statistical diesel dispatch criteria would otherwise allow that. Therefore, Statistical Diesel Dispatch will not allow a diesel to be taken off-line if the system is facing imminent loss of a non-diesel generation component because of a warning or operator request to disable. This is accomplished by temporarily making *Diesel Capacity Required* equal to the larger of the *Diesel Capacity Required* (as determined by the statistical diesel dispatch criteria) or the diesel capacity currently on-line before executing Diesel Run Select.

##### Diesel Disable Requests

If the operator has requested to disable a currently running diesel, Statistical Diesel Dispatch will instruct Diesel Run Select to select a new diesel combination that can supply the *Diesel Capacity Required* but does not include the specified diesel. Execution of Diesel Run Select will be suppressed; however, if the system is facing imminent loss of any other generation component because of the risk involved with taking a diesel off-line at the same time another component may be going off-line due to a warning or disable request.

##### Operator Mode Change Requests

Switching from one system operating mode to a lower operating mode may involve taking a component off-line. Therefore, operator requests to change to a lower operating mode will project a new state. Because the statistical diesel dispatch criteria are based on projected state, the *Diesel Capacity Required* value determined by these criteria takes into consideration operator requests to change to a lower operating mode. However, if the operator-requested mode change would require additional diesel capacity, the operator may wish to cancel the mode change request. Therefore, if the operator has requested to change to a lower operating mode, Statistical



Diesel Dispatch will determine whether there is sufficient diesel capacity already on-line, sufficient diesel capacity available but not on-line, or insufficient diesel capacity available to enter the new mode. This information will be provided to the operator via the touchscreen along with prompts to either continue with or cancel the mode change request. Statistical Diesel Dispatch will allow Diesel Run Select to execute only when the operator requests to continue with the mode change.

#### Diesel kVA Support for a Wind Turbine Start

The Atlantic Orient Company (AOC) wind turbine has a large inrush current when its contactor closes. To prevent this inrush from causing an unacceptable voltage flicker, it is necessary to ensure that there is sufficient kVA capacity on-line to provide this inrush current before allowing a wind turbine to start. The amount of kVA capacity required is defined to be the most recent 1-minute average kVA load plus a user-specified amount of excess kVA capacity required for a wind turbine start. If the amount of kVA capacity required is less than the total kVA capacity on-line, then additional kVA capacity must be provided, either by the AC machine or another diesel. If the system is in Mode 2 or 3, the AC machine is not already on-line, and there is sufficient diesel capacity to run the pony motor (at least 10 kW excess diesel capacity on-line to provide the power to spin the rotary converter up to speed), then the AC machine will be dispatched to provide the additional kVA capacity. However, if any of these requirements are not met, then a diesel(s) will be dispatched to provide the additional kVA capacity. This is accomplished by making *Diesel Capacity Required* equal to the larger of the *Diesel Capacity Required* as determined by the main statistical diesel dispatch criteria or the total kVA capacity requirement (including the excess required by the wind turbine start), minus the rotary converter kVA capacity (if the AC machine is already on-line), the result converted to a kW equivalent. This revised *Diesel Capacity Required* is determined before executing Diesel Run Select.

#### **4.1.1.2 Instantaneous Diesel Dispatch**

Statistical diesel dispatch peak kW criteria uses recent statistical values of wind power and load to predict the maximum kW load that must be supplied by the diesels in the near future and dispatches diesel capacity accordingly. The recent past is a good predictor of the near future; however, it is not perfect. There may be cases where an unanticipated change in wind power or village load causes the load that must be supplied by the diesels at any given instant to exceed the diesel capacity on-line. Therefore, Instantaneous Diesel Dispatch is provided to serve as a backup to Statistical Diesel Dispatch. The objective of Instantaneous Diesel Dispatch is to immediately dispatch additional diesel capacity if the kW load that must be met by the diesels at any given instant approaches or exceeds the amount of diesel capacity on-line at that instant. This is accomplished by monitoring instantaneous power quantities and immediately dispatching additional diesel capacity if they exceed specified limits. Instantaneous diesel dispatch criteria are evaluated on every PLC scan.

Instantaneous Diesel Dispatch consists of the following steps:

1. Determining the appropriate instantaneous diesel dispatch mode

2. Evaluating the corresponding criteria to determine Instantaneous *Diesel Capacity Required* and determining whether or not the resulting value warrants executing Diesel Run Select.

#### 4.1.1.2.1 Instantaneous Diesel Dispatch Modes

The first step in Instantaneous Diesel Dispatch is to determine the appropriate dispatch mode. The current System State dictates which instantaneous power quantities should be monitored to determine whether or not additional diesel capacity is required. Therefore, the instantaneous diesel dispatch modes are based on the current System State. There are four instantaneous diesel dispatch modes:

- Instantaneous Diesel Dispatch State 1A and State 1B
- Instantaneous Diesel Dispatch State 2A and State 2B
- Instantaneous Diesel Dispatch State 3
- Instantaneous Diesel Dispatch State 4, State 5, State 6, and State 7

#### 4.1.1.2.2 Instantaneous Diesel Dispatch Criteria

Unlike statistical diesel dispatch, there is only one criterion associated with each instantaneous diesel dispatch mode. The criterion is based on instantaneous kW quantities. There is no need to monitor instantaneous kVAR or kVA quantities because the kVAR and kVA capacities of a generator are limited by heating effects in the windings and can therefore be exceeded (within saturation limits) on an instantaneous basis without harm.

Once Instantaneous Diesel Dispatch has determined the appropriate dispatch mode, the next step is to evaluate the corresponding dispatch criterion to determine Instantaneous *Diesel Capacity Required*.

Statistical diesel dispatch peak kW criteria and instantaneous diesel dispatch criteria are similar, but there is an important difference. The statistical diesel dispatch peak kW criteria determine *Diesel Capacity Required* based on the predicted the maximum kW load that must be met by the diesels in the near future, while the instantaneous diesel dispatch criteria determine it based on actual instantaneous power measurements. The statistical criteria use certain power quantities, e.g., village kW and total wind kW, which are calculated and averaged over a several-second interval and cannot be measured instantaneously.\* However, the instantaneous diesel dispatch criteria must be based exclusively on quantities that can be measured instantaneously, such as diesel kW and dump load kW.

---

\* Each wind turbine controller is polled sequentially via radio link to determine its power output. The individual turbine power levels are summed to determine total wind power. Because of communication delays and nonconcurrent sampling, this total must be low pass filtered to eliminate sampling errors.

As previously stated, the objective of Instantaneous Diesel Dispatch is to immediately dispatch additional diesel capacity if the generation capacity on-line is insufficient to meet the instantaneous primary load with adequate safety margin. The specific instantaneous power quantities used depend on whether or not the current state includes the diesel generators and the battery bank.

#### Instantaneous Diesel Dispatch: State 1A, 1B, 2A, and 2B

In states that do not include the battery bank but do include a diesel generator, then the kW load that must be met by the diesels at any given instant is that portion of the primary kW load that is greater than the wind power at any given instant. This can be calculated, using instantaneous quantities, as the total diesel kW minus the total dump load kW. (Recall that diesel capacity need only be dispatched to ensure the primary kW load is met. Dump load is subtracted because it is a secondary load and need not be met.) The instantaneous *Diesel Capacity Required* is then obtained by dividing this primary diesel kW load value by a user-specified *Maximum Allowed % Diesel Loading*. If the resulting *Diesel Capacity Required* is greater than the diesel capacity on-line, Diesel Run Select is executed. The *Maximum Allowed Instantaneous % Diesel Loading* parameter provides a safety margin to allow for the fact that a diesel cannot be started instantaneously. There are actually two *Maximum Allowed Instantaneous % Diesel Loading* values, one which applies if there are wind turbines on-line and one which applies if there are no wind turbines on-line. The former is more conservative to provide a larger safety margin to accommodate fluctuations in wind power.

Instantaneous Diesel Dispatch Criterion for Operation in State 1A (Diesel Only/AC Machine Off), State 1B (Diesel Only/AC Machine On), State 2A (Diesel + Wind/AC Machine Off), or State 2B (Diesel + Wind/AC Machine On):

$$\text{Instantaneous Diesel Capacity Required} = \frac{\text{Diesel kW} - \text{Dump Load kW}}{\text{Maximum Allowed Instantaneous \% Diesel Loading}}$$

#### Instantaneous Diesel Dispatch: State 3

During operation in a state that does not include the battery bank or a diesel generator (wind-only operation), the system is most vulnerable to power outages. Therefore, wind-only operation will only be allowed if the wind power is sufficient to cover the primary kW load *and* maintain a user-specified amount of excess power, called the *Wind-Only Dump Load Margin*. The *Wind-Only Dump Load Margin* acts as a safety margin should the primary kW load exceed the wind power. A diesel must be started if the excess wind power drops below this safety margin. In wind-only operation, the excess wind power is equal to the total dump load kW. If this value is less than the *Wind-Only Dump Load Margin*, Instantaneous Diesel Dispatch will cause a diesel to start by setting *Diesel Capacity Required* equal to the *Instantaneous Diesel Capacity Required* and executing Diesel Run Select.

Instantaneous Diesel Dispatch Criterion for Operation in State 3 (Wind Only):

$$\text{Instantaneous Diesel Capacity Required} = \text{Wind Only DL Margin} - \text{Dump Load kW}$$

Instantaneous Diesel Dispatch: States 4, 5, 6, and 7

If the current state includes the battery bank, then the batteries can also be discharged to meet the primary kW load. By supplying power during short-term peak loading conditions caused by transient dips in wind power, the batteries can eliminate the need to start another diesel. The maximum amount of AC kW power that can be delivered from the batteries through the rotary converter is called the *Rotary Converter kW Limit*. Therefore, during operation in any state that includes in the battery bank, the instantaneous *Diesel Capacity Required* is that portion of the primary kW load that is greater than the sum of the wind power and the *Rotary Converter kW Limit*. The expression for instantaneous *Diesel Capacity Required* is given below. In this case, it is not necessary to provide a safety margin in the form of *Maximum Allowed % Diesel Loading* because the *Rotary Converter kW Limit* provides that safety margin by being less than the actual transient capacity of the battery bank/rotary converter. If the instantaneous *Diesel Capacity Required* exceeds the diesel capacity on-line, Diesel Run Select is executed.

Instantaneous Diesel Dispatch Criterion for Operation State 4 (Diesel + Battery), State 5 (Diesel + Wind + Battery), State 6 (Wind + Battery), or State 7 (Battery Only):

$$\text{Instantaneous Diesel Capacity Required} = \text{Diesel kW} + \text{Rotary Converter AC kW} - \text{Dump Load kW} - \text{Rotary Converter kW Limit}$$

#### **4.1.2 Diesel Combination Selection (Diesel Run Select)**

Once the amount of diesel generating capacity required is known, the second phase of Diesel Dispatch is to determine the optimal combination of diesel generators to provide the required capacity. This process is called Diesel Run Select.

This process executes differently, depending on whether or not Statistical Diesel Dispatch has determined that it is OK to shut off all diesels.

##### **4.1.2.1 Diesel-Off Operation Not Allowed**

The primary objective in selecting a diesel combination to meet the required capacity is maximum efficiency, therefore the ideal approach would be to use the fuel curve of each diesel generator to find the combination of diesels with the lowest total fuel consumption rate at that load. However, this method has several drawbacks. It is computation intensive, and more

importantly, it does not allow the system operator to run certain generators above others for reasons other than efficiency. A plant operator may prefer to run a certain generator over another to concentrate run-time on the first generator. This is often done with equivalent or nearly equivalent generators so that they do not require overhaul at the same time. The “ideal” approach described above would not accommodate this plant operating strategy, since it dispatches diesels strictly according to maximum fuel efficiency.

The Wales wind-diesel control system uses a practical approach to diesel combination selection. This method is based on an operator-prioritized table of diesel combinations and therefore allows for operator preferences. The operator can setup and change the diesel combination table at any time using the Wind-Diesel Control Panel (WDCP) touchscreen.

Diesel Run Select will search through the operator-prioritized table of diesel combinations for the first diesel combination that meets the following requirements:

1. Combination capacity  $\geq$  *Diesel Capacity Required*
2. All diesels in the combination are available
3. None of the diesels in the combination have a warning \*
4. The combination would not shut off any diesels that are currently on-line but have not met their minimum run-time.

A fifth and final requirement applies only if the system is not facing imminent loss of any other component:

5. None of the on-line diesels in the combination have a pending operator request to be disabled by the operator (but are still enabled because they are still on-line).<sup>††</sup>

If any combination fails to meet all these requirements, Diesel Run Select will skip that combination and resume the search. If none of the diesel combinations meet all these requirements, then there is insufficient diesel capacity available to meet the *Diesel Capacity Required*. In this case, Diesel Run Select will require only that all the diesels in the combination be available and will select the combination that has the largest capacity of all the combinations that meet this requirement.

---

\* If a diesel generator has a warning condition, a controlled shutdown of that diesel will be initiated. However, while it is still on-line, it is considered available, even though it has a warning. It will not become unavailable until it goes off-line.

† When the operator requests to disable a diesel generator that is on-line, the control system will first ensure that there is sufficient generating capacity on-line without that diesel. Only then will it be taken off-line and disabled.

#### **4.1.2.2 Diesel-Off Operation Allowed**

If Statistical Diesel Dispatch has determined that it is acceptable to shut all the diesels off, Diesel Run Select will allow all diesels to be shut off except for those that have not met their minimum run-time.

## **4.2 Wind Turbine Dispatch**

In a low-penetration wind-diesel system any and all available wind turbines may be operated whenever there is sufficient wind. In a high-penetration system, however, it is sometimes necessary to limit wind turbine capacity on-line to avoid producing more power than can be controlled by the system. This is the function of Wind Turbine Dispatch.

Because the wind turbines are a multiple-unit component group, Wind Turbine Dispatch consists of two phases:

1. Determining wind turbine generating capacity allowed to be on-line at any given moment
2. Determining which wind turbines to allow to start/take off-line in order not to exceed the allowed capacity (this process is called Wind Turbine Run Select).

Wind Turbine Dispatch is thus distinct from Wind Turbine Control, which is the process of turning on/off actual control signals to release/engage the turbine brakes and close/open the turbine contactor. Wind Turbine Control is performed by each individual wind turbine controller. Wind Turbine Dispatch is enabled if the system is operating in Auto Mode 1, 2, or 3. It is disabled if the system is operating in Manual Mode or Auto Mode 0.

The following sections describe the two phases of Wind Turbine Dispatch.

### **4.2.1 Determining Wind Turbine Capacity Allowed**

*Wind Turbine Capacity Allowed* is defined as the maximum amount of wind turbine capacity that can be on-line without risk of overpowering the bus. This amount depends in part on the amount of wind power the system can absorb, which, in turn, depends on the primary load, the amount of secondary load available, and the required minimum power contribution from the diesels.\* However, *Wind Turbine Capacity Allowed* is not simply equal to the amount of wind power the system can absorb, or wind turbine power output allowed. At lower wind speeds, *Wind Turbine Capacity Allowed* will be greater than the actual wind turbine power output allowed because each turbine is producing less than rated power. Similarly, at higher wind speeds, *Wind Turbine Capacity Allowed* may be less than the actual wind turbine power output allowed because each turbine may be producing more than rated power.

---

\* If any diesels are on-line, they must be operated at least at the user-specified Minimum Diesel % Loading.

To convert wind turbine power output allowed to *Wind Turbine Capacity Allowed*, the wind turbine power output allowed is divided by the recent average wind turbine capacity factor, which is the ratio of the actual power output of the wind turbines to the rated capacity of the wind turbines. In this way, the calculation of *Wind Turbine Capacity Allowed* takes into account prevailing wind conditions.

Wind Turbine Dispatch is based on both statistical and instantaneous dispatch criteria. Statistical dispatch criteria can increase or decrease *Wind Turbine Capacity Allowed* to allow a wind turbine(s) to come on-line or take a wind turbine(s) off-line. Instantaneous dispatch criteria can only decrease *Wind Turbine Capacity Allowed* in order to immediately take a wind turbine(s) off-line if there is insufficient load available on the bus to absorb the wind power.

#### **4.2.1.1 Statistical Wind Turbine Dispatch**

Statistical wind turbine dispatch criteria serve as the foundation of wind turbine dispatch. Their objective is to predict the amount of wind power the system can absorb as well as the actual wind turbine power output in the near future, and to dispatch wind turbine capacity accordingly. Statistical wind turbine dispatch criteria are evaluated every minute, or in response to special events that indicate an imminent loss of remote dump load, or if a diesel has just been brought on-line or taken off-line. (The last condition is necessary because the required power contribution from the diesel generators changes when the amount of diesel capacity on-line changes.) The process of evaluating statistical wind turbine dispatch criteria is called Statistical Wind Turbine Dispatch.

Statistical Wind Turbine Dispatch consists of the following steps:

1. Determining the appropriate statistical wind turbine dispatch mode
2. Evaluating the corresponding criteria to determine *Wind Turbine Capacity Allowed*
3. Determining whether or not it is acceptable to allow a (or another) turbine to start and executing Wind Turbine Run Select.

The following sections describe these steps.

##### **4.2.1.1.1 Statistical Wind Turbine Dispatch Modes**

The first step in Statistical Wind Turbine Dispatch is to determine the appropriate dispatch mode. The amount of wind power the system can absorb depends on total available load on the bus, which consists of the village load and the total available dump load.\* The total available dump load consists of local dump load and remote dump load if it is available.

---

\* In reality, both the kW required to spin the rotary converter (if the AC machine is on-line) and the kW required to boost charge the battery (if the system is boost charging) also contribute to the total load on the bus. However, these loads are negligible and have been excluded from

Local dump load must be available for the system to be in any of the operating modes in which wind turbine operation is allowed.\* Sometimes the system has advance warning that one of the dump loads will soon become unavailable, as when the operating temperature of its corresponding hydronic loop is reached. If there is an imminent loss of local dump load, then the system will drop into Mode 0, and all operating wind turbines will be shut down. This is not considered part of wind turbine dispatch. The standard mode of Statistical Wind Turbine Dispatch assumes that local dump load is available and that if remote dump load is available, it will remain available. However, in the case of imminent loss of remote dump load, there is a second dispatch mode, which adjusts the *Wind Turbine Capacity Allowed* to reflect the soon-to-be-reduced dump load capacity available.

Thus, there are two statistical wind turbine dispatch modes:

- Statistical Wind Turbine Dispatch Standard Mode
- Statistical Wind Turbine Dispatch Lose Remote Dump Load Mode.

#### 4.2.1.1.2 Statistical Wind Turbine Dispatch Criteria

Once Statistical Wind Turbine Dispatch has determined the appropriate dispatch mode, the next step is to evaluate the corresponding dispatch criteria to determine *Wind Turbine Capacity Allowed*. There are three criteria in each statistical wind turbine dispatch mode: Average kW, Peak kW, and Minimum Instantaneous. The final *Wind Turbine Capacity Allowed* value will be the smallest of the values given by each of the three criteria.

##### Statistical Wind Turbine Dispatch Average kW Criterion

The statistical wind turbine dispatch average kW criterion determines the maximum amount of wind turbine capacity that ensures that the average near-future total available load is sufficient to absorb the average near-future wind power plus the required contribution from the diesel generators.

Predicting the average future total available kW load requires predicting the average future village kW load. Although not perfect, the recent past is the best available predictor of the future. Therefore, the average kW criterion uses the most recent 20-minute average value of village kW load to determine the expected average village kW load. The expected average wind power output is predicted using the most recent 20-minute average wind turbine capacity factor.

The following is an example of a statistical wind turbine dispatch average kW criterion, the one that applies if the system is *not* about to lose remote dump load:

---

Statistical Wind Turbine Dispatch. The only effect this simplification has is to make Statistical Wind Turbine Dispatch slightly more conservative.

\* However, sudden loss of remote dump load could cause there to be insufficient load available on the bus to absorb all the wind power and could result in an overfrequency shutdown.



$$\text{Wind Turbine Capacity Allowed} = \frac{\text{Village kW 10m Average} + \text{Total Dump Load kW Available} - \text{Minimum Diesel kW Load}}{\text{Wind Turbine Capacity Factor 10m Average}}$$

### Statistical Wind Turbine Dispatch Peak kW Criterion

The objective of the statistical wind turbine dispatch peak kW criterion is to determine the maximum wind turbine capacity that ensures that the minimum near-future total available load is sufficient to absorb the maximum near-future wind power while maintaining a user-specified amount of unused dump load.

The statistical wind turbine dispatch peak kW criterion does not subtract the minimum diesel load from the total available kW load to determine the amount of wind power the system can absorb. This is because the minimum diesel load is considered available to absorb wind power (by unloading the diesel) on a transient basis. However, this leaves the system without a load buffer to absorb unanticipated wind power spikes. This buffer can be provided in the form of unused, or excess, dump load. Because the magnitude of the possible wind power spikes depends on the amount of wind turbine capacity on-line, the required excess dump load is calculated as a user-specified percentage of the wind turbine capacity on-line. This percentage is called the *Dump Load Headroom %*.

The following is an example of a statistical wind turbine dispatch peak kW criterion, the one that applies if the system is *not* about to lose remote dump load:

$$\text{Wind Turbine Capacity Allowed} = \frac{(\text{Village kW 20m Minimum} + \text{Total Dump Load kW Available} - \text{Wind Turbine Capacity OnLine} \times \text{Dump Load kW Headroom \%})}{\text{Wind Turbine Capacity Factor 20m Maximum}}$$

### Statistical Wind Turbine Dispatch Minimum Instantaneous Wind Turbine Capacity Allowed

Instantaneous Wind Turbine Dispatch will take a wind turbine off-line immediately if the instantaneous power quantities on which the instantaneous wind turbine dispatch criteria are based exceed user-specified limits (see Section 4.2.1.2). However, the *Wind Turbine Capacity Allowed* determined by the main statistical wind turbine dispatch criteria may not have changed by the time those criteria execute next. This could result in Statistical Wind Turbine Dispatch adding a wind turbine after Instantaneous Wind Turbine Dispatch has just removed one. The Minimum Instantaneous Wind Turbine Capacity Allowed Criterion is to prevent this from happening by ensuring that *Wind Turbine Capacity Allowed* is never greater than the most recent 20-minute minimum Instantaneous *Wind Turbine Capacity Allowed*. The criterion is the same regardless of whether the system is about to lose remote dump load or not.

Statistical Wind Turbine Dispatch Minimum Instantaneous Wind Turbine Capacity Allowed Criterion:

$$\text{Wind Turbine Capacity Allowed} = \text{Instantaneous Wind Turbine Capacity Allowed 20m Minimum}$$

#### 4.2.1.1.3 Statistical Wind Turbine Dispatch Wind Turbine Start Criteria

Once Statistical Wind Turbine Dispatch has determined the appropriate dispatch mode and evaluated the corresponding dispatch criteria to determine *Wind Turbine Capacity Allowed*, the next step is to determine whether or not it is alright to allow a turbine to start. *Wind Turbine Capacity Allowed* greater than wind turbine capacity currently on-line does *not* necessarily mean that a wind turbine can be started, even if the difference is greater than the capacity of a single turbine. There are two conditions that must be met before a turbine will be allowed to start: (1) the system must not be facing imminent loss of remote dump load, and (2) there must be sufficient available load to start a turbine. The first condition is straightforward. The second condition involves several additional considerations.

First, the required excess dump load included in the statistical wind turbine dispatch peak kW criterion, and therefore used to help determine *Wind Turbine Capacity Allowed*, was based on the amount of wind turbine capacity currently on-line. There must be an additional turbine's worth of required excess dump load to allow a turbine to start.

Second, when a wind turbine comes on-line, it initially generates a surge of extra power before dropping to a lower power level consistent with the wind speeds. There must be sufficient excess dump load to absorb this power surge to allow a wind turbine to start. This requires quantifying the largest expected power surge, called the *Wind Turbine Start Overshoot*. This value is equal to the maximum wind power the particular wind turbine is expected to produce multiplied by a user-specified power surge factor, called the *Wind Turbine Start Power Surge Factor*. The maximum wind power the particular wind turbine is expected to produce is based on its capacity and the recent 20-minute maximum capacity factor of other turbines on-line, if any.

The *Wind Turbine Start Overshoot* is given by the following expression:

$$\text{Wind Turbine Start Overshoot} = \text{Wind Turbine Capacity} \times \text{Wind Turbine Capacity Factor 20m Maximum} \times \text{Wind Turbine Power Surge Factor}$$

#### 4.2.1.2 Instantaneous Wind Turbine Dispatch

There is only one instantaneous wind turbine dispatch mode and one instantaneous wind turbine dispatch criterion, therefore Instantaneous Wind Turbine Dispatch consists of evaluating the criterion to determine Instantaneous *Wind Turbine Capacity Allowed* and determining whether or not the resulting value warrants executing Wind Turbine Run Select.

Statistical wind turbine dispatch peak kW criteria attempt to ensure that the minimum near-future total available kW load is sufficient to absorb the maximum near-future wind power. These criteria rely on predictions of expected wind power and load. Instantaneous Wind Turbine Dispatch is provided to serve as a backup to Statistical Wind Turbine Dispatch. Instantaneous Wind Turbine Dispatch immediately takes a wind turbine off-line if the wind power exceeds the total available kW load minus the user-specified amount of required excess dump load. Instantaneous Wind Turbine Dispatch criteria are evaluated every PLC scan.

As with diesel dispatch, the statistical wind turbine dispatch criteria use certain power quantities that are calculated and averaged over a several-second interval and cannot be measured instantaneously. However, the instantaneous wind turbine dispatch criteria must be based exclusively on quantities that can be measured instantaneously, such as diesel kW and dump load kW.

Excess wind power can be expressed in terms of instantaneous power quantities by the *Secondary Load Request* (as determined by the diesel load control algorithm in the system controller). The objective of instantaneous wind turbine dispatch criteria expressed in terms of instantaneous quantities is then to immediately take a wind turbine off-line if the *Secondary Load Request* plus the user-specified amount of required excess dump load exceeds the total dump load available plus the total diesel load. Diesel load is added because it is considered available to absorb wind power (by unloading the diesel) on a transient basis. Instantaneous excess wind power is converted to an equivalent wind turbine capacity using the *Instantaneous Wind Turbine Capacity Factor*.

Instantaneous Wind Turbine Dispatch Criterion:

$$\begin{aligned} & \text{Instantaneous Wind Turbine Capacity Allowed} = \\ & \text{Wind Turbine Capacity On Line} - \\ & \frac{(\text{Secondary Load Request} + \text{WT Capacity OnLine} \times \text{Dump Load kW Headroom\%} - \text{Total Dumpload kW Available} - \text{Diesel kW})}{\text{Instantaneous Wind Turbine Capacity Factor}} \end{aligned}$$

If the *Wind Turbine Capacity Allowed* is less than the current wind turbine capacity on-line, Instantaneous Wind Turbine Dispatch will cause a wind turbine to be removed by setting *Wind Turbine Capacity Allowed* equal to the *Instantaneous Wind Turbine Capacity Allowed* value just determined and executing Wind Turbine Run Select.

### 4.2.2 *Wind Turbine Run Select*

Once the amount of *Wind Turbine Capacity Allowed* to be on-line is known, the second phase of Wind Turbine Dispatch is to determine which wind turbines to allow to start or take off-line in order not to exceed the allowed capacity. This process is called Wind Turbine Run Select.

Wind Turbine Run Select determines how many wind turbines are allowed to be on-line by dividing *Wind Turbine Capacity Allowed* by the capacity of a single wind turbine.\* Wind Turbine Run Select then compares the number of wind turbines allowed to be on-line to the number of wind turbines actually on-line.

To approximately equalize run time on the wind turbines, the wind turbines are started and stopped in a first-on, first-off (FIFO) manner. If a turbine needs to be taken off-line, Wind Turbine Run Select will search the list of turbines for the turbine that was the first to come on-line and select that one to be taken off-line. If more than one turbine needs to be taken off-line, Wind Turbine Run Select will repeat the process, searching for the next turbine that is on-line.

If a turbine can be allowed to start, as determined by Statistical Wind Turbine Dispatch, Wind Turbine Run Select will search the list of turbines for the turbine that has been off-line the longest and is ready to run (available and sufficient winds) and select that one to start. If more than one turbine can be allowed to start, Wind Turbine Run Select will repeat the process, searching for the next turbine that is ready but not already on-line.†

### 4.3 AC Machine Dispatch

Because there is only one AC machine, AC Machine Dispatch simply consists of deciding when to run the AC machine and when to shut it off. AC Machine Dispatch is distinct from AC Machine Run Control, which is the software module that controls the starting and stopping of the AC machine. AC Machine Run Control is performed by the Rotary Converter Control Cabinet (RCCC) PLC. AC Machine Dispatch is enabled if the system is operating in Auto Mode 2 or 3. It is disabled if the system is operating in Manual Mode, Auto Mode 0, or Auto Mode 1.

AC Machine Dispatch is based on both statistical and instantaneous dispatch criteria. Statistical dispatch criteria determine both when to bring the AC machine on-line and when to take it off-line. Instantaneous dispatch criteria act only to prevent the AC machine from coming on-line when there is insufficient diesel capacity to run the pony motor.

The following sections describe these two criteria.

---

\* This algorithm assumes that all the wind turbines have the same capacity. This method would need to be modified to accommodate different-sized turbines.

† To avoid the large power transient that would result from multiple simultaneous wind turbine contactor closures, only one turbine is allowed to actually start at a time.

### **4.3.1 Statistical AC Machine Dispatch**

Statistical AC machine dispatch criteria serve as the foundation of AC machine dispatch. Their objective is to determine if any system conditions exist under which the AC machine could provide a benefit and to dispatch the AC machine if that is the case. The primary benefit that the AC machine could provide is to allow diesel-off operation under certain conditions. In addition, the AC machine can be used to prevent another diesel from starting under other conditions. Statistical AC Machine Dispatch will dispatch the AC machine if any of these conditions exist. Statistical AC Machine Dispatch will take the AC machine off-line if none of these conditions exist and there is at least one diesel on-line.

Statistical AC machine dispatch criteria are evaluated every minute. The process consists of the following steps:

1. Determining whether or not there is sufficient diesel capacity to run the pony motor
2. Determining the appropriate statistical AC machine dispatch mode
3. Determining if the AC machine could be used to allow diesel-off operation
4. Determining whether or not the AC machine could be used to eliminate the need to start another diesel.

The following sections describe these steps.

#### **4.3.1.1 Sufficient Diesel Capacity to Run the Pony Motor**

The first step in Statistical AC Machine Dispatch is to determine whether or not there is sufficient diesel capacity to run the pony motor. If the AC machine is not on-line yet, it must be spun up to speed by the pony motor. The pony motor's peak power draw is about 10 kW. Therefore, regardless of other system conditions, Statistical AC Machine Dispatch will not initially dispatch the AC machine unless diesel capacity on-line is at least 10 kW greater than *Diesel Capacity Required* (as determined by Diesel Dispatch). This requirement no longer applies once the AC machine is already on-line.

#### **4.3.1.2 Statistical AC Machine Dispatch Modes**

The next step in Statistical AC Machine Dispatch is to determine the appropriate dispatch mode. The primary benefit that the AC machine could provide is to allow diesel-off operation if system conditions exist that would otherwise allow diesel-off operation. Principally, there must be sufficient wind power to allow diesel-off operation. Recall from Statistical Diesel Dispatch Diesel-Off that the criteria used to determine if there is sufficient wind power to allow diesel-off operation depend on whether the battery bank/DC machine is projected to be on-line or not. Therefore, the AC machine dispatch modes are based on whether the battery bank/DC machine is allowed to be on-line or not:

1. Statistical AC Machine Dispatch DC Not Allowed Mode
2. Statistical AC Machine Dispatch DC Allowed Mode

The battery bank/DC machine is only allowed to be on-line if the system is in Auto Mode 3 and the batteries are not being boost charged.

#### **4.3.1.3 Diesel-Off Criteria**

Once Statistical AC Machine Dispatch has determined the appropriate dispatch mode, the next step is to determine whether or not diesel-off operation would be allowed if the AC machine were on-line. Statistical Diesel Dispatch requires that there be sufficient wind power to shut all the diesels off before diesel-off operation is allowed. Furthermore, Diesel Run Select will not actually shut all the diesels off until all of them have met their minimum run-time. Therefore, Statistical AC Machine Dispatch must ensure both these requirements, as well as sufficient diesel capacity to run the pony motor, before dispatching the AC machine for the purpose of allowing diesel-off operation.

The minimum run-time requirement is straightforward. However, two criteria must be met to satisfy the sufficient wind power requirement. Not surprisingly, these are the same criteria used by Statistical Diesel Dispatch to determine whether or not diesel-off operation is allowed. In addition, if the battery bank/DC machine is allowed to be on-line, these are the same criteria used by DC Machine Dispatch to determine whether or not to run the DC machine. Therefore, both components would be dispatched at the same time.

#### **4.3.1.4 Statistical AC Machine Dispatch Additional Considerations**

Once Statistical AC Machine Dispatch has determined the appropriate dispatch mode and determined if diesel-off operation would be allowed if the AC machine were on-line, the last step is determine if there are any additional conditions under which the AC machine could provide a benefit. These additional considerations are described below.

##### Rotary Converter kVA Support for a Wind Turbine Start

A significant amount of current is required to magnetize the AOC wind turbine's induction generator when the turbine first comes on-line. It is necessary to ensure that there is sufficient kVA capacity on-line to provide this inrush current before allowing a wind turbine to start. The amount of kVA capacity required is defined to be the most recent 1-minute average kVA load plus a user-specified amount of excess kVA capacity required for a wind turbine (WT) start. If the amount of kVA capacity required is less than the total kVA capacity on-line, then additional kVA capacity must be provided, either by the AC machine or another diesel. We would prefer to dispatch the AC machine rather than another diesel. Therefore, if additional kVA capacity is required for a wind turbine start, the AC machine is not already on-line, and there is sufficient diesel capacity to run the pony motor, then Statistical AC Machine Dispatch will dispatch the AC

machine. If any of these requirements are not met, or if the system is not in Mode 2 or 3, then a diesel will be dispatched to provide the additional kVA capacity.

### Rotary Converter kVAR Support

The AOC wind turbines are provided with power factor correction capacitors. However, each turbine still consumes up to about 30 kVAR of reactive power. If there are multiple wind turbines on-line, it is possible that the amount of *Diesel Capacity Required* to meet the kVAR demands of the system may be significantly greater than the amount of *Diesel Capacity Required* to meet the kW demands of the system. In these cases, the control system dispatches the AC machine rather than another diesel to provide the kVAR support. To do so, it is necessary to dispatch the AC machine before the kVAR load exceeds the kVAR capacities of the diesel generators on-line in order to prevent another diesel from being dispatched first. Therefore, if the most recent 1-minute average kVAR load exceeds 90% of the current diesel kVAR capacity on-line, the AC machine is not already on-line, and there is sufficient diesel capacity to run the pony motor, then Statistical AC Machine Dispatch will dispatch the AC machine.\*

### **4.3.2 Instantaneous AC Machine Dispatch**

There is only one instantaneous AC machine dispatch mode and one instantaneous AC machine dispatch criterion. Recall that Statistical AC Machine Dispatch checks for sufficient diesel capacity to run the pony motor before dispatching the AC machine. However, an unexpected change in wind power or load could cause there to no longer be sufficient diesel capacity to run the pony motor. Instantaneous AC Machine Dispatch acts only to immediately abort AC machine dispatch if this situation results in a diesel overload before the AC machine is actually on-line. This is accomplished by monitoring instantaneous diesel kW load. If the instantaneous diesel kW load exceeds the diesel capacity on-line and the AC machine is not yet on-line, AC machine dispatch will be aborted. This criterion is evaluated every PLC scan.

## **4.4 DC Machine Dispatch**

Because there is only one DC machine, DC Machine Dispatch simply consists of deciding when to run the DC machine and when to shut it off. DC Machine Dispatch is distinct from DC Machine Run Control, which is the procedure followed to bring the DC machine on-line and take it off-line. DC Machine Run Control is performed by the Rotary Converter Control Cabinet PLC. DC Machine Dispatch is enabled if the system is operating in Auto Mode 3 and the

---

\* If the amount of diesel capacity required to meet the kVAR demands of the system is significantly greater than the amount of diesel capacity required to meet the kW demands of the system, the current method will dispatch the AC machine to prevent another diesel from being started. However, if another diesel had already been started for other reasons (e.g., to provide kVA support for a wind turbine start), this method will *not* dispatch the AC machine to allow one of the diesels to shut off. In the latter case, both diesels would remain on due to the kVAR demands. This will be addressed in future versions of the control program.

batteries are not being boost charged. It is disabled if the system is operating in Manual Mode, Auto Mode 0, Auto Mode 1, or Auto Mode 2 or if the batteries are being boost charged (the auxiliary battery charger and the DC machine must never be on-line at the same time).

DC Machine Dispatch is based on statistical dispatch criteria only. There are no instantaneous DC machine dispatch criteria because there are no power flow conditions that would require the DC machine to be taken off-line immediately. In addition, there is only one DC machine dispatch mode. The DC machine dispatch criteria are evaluated every minute.

The objective of DC Machine Dispatch is to determine if system conditions are such that diesel-off operation would be allowed if the DC machine were on-line and to dispatch the DC machine if so. DC Machine Dispatch will dispatch the DC machine if these conditions exist and take the DC machine off-line if they do not.

Statistical Diesel Dispatch requires that there be sufficient wind power to shut off all the diesels before diesel-off operation is allowed. Furthermore, Diesel Run Select will not actually shut off all the diesels until all of them have met their minimum run-time. Therefore, Statistical DC Machine Dispatch must ensure both these requirements before dispatching the DC machine.

The minimum run-time requirement is straightforward. However, two criteria must be met to satisfy the sufficient wind power requirement. Not surprisingly, these are the same criteria used by Statistical Diesel Dispatch to determine if diesel-off operation is allowed. In addition, these are the same criteria used by AC Machine Dispatch to determine whether or not to run the AC machine if the battery bank/DC machine is allowed to be on-line. Therefore, both components would be dispatched at the same time.

#### **4.5 Auxiliary Battery Charger Dispatch**

The need for boost charging is discussed in Section 8.5. Because there is only one auxiliary battery charger, Auxiliary Battery Charger Dispatch, or Boost Charge Dispatch, simply consists of deciding when to turn the battery charger on to boost charge the batteries and when to shut it off.\*

Boost Charge Dispatch is distinct from Boost Charge Control, which is the procedure followed to actually bring the battery charger on-line and boost charge the batteries. Boost Charge Control is performed by the RCCC PLC.

Auxiliary Battery Charger Dispatch is enabled if the system is operating in Auto Mode 0, Auto Mode 1, or Auto Mode 2, or if the system is operating in Auto Mode 3 and the DC machine is not on-line (the auxiliary battery charger and the DC machine must never be on-line at the same time). It is disabled if the system is operating in Manual Mode or if the system is operating in Mode 3 and the DC machine is on-line.

---

\* *Boost Charge Dispatch* refers to automatic dispatch of the auxiliary battery charger by the WDCP Controller. The operator can also manually request a boost charge.



Boost Charge Dispatch is based on both statistical and instantaneous dispatch criteria. Statistical dispatch criteria determine when to bring the auxiliary battery charger on-line. Instantaneous dispatch criteria determine when to take the auxiliary battery charger off-line. The following sections describe these two criteria.

#### **4.5.1 Statistical Boost Charge Dispatch Criteria**

Statistical boost charge dispatch criteria are evaluated every minute. The process of evaluating statistical boost charge dispatch criteria is referred to as *Statistical Boost Charge Dispatch*. There is only one statistical boost charge dispatch mode.

Statistical Boost Charge Dispatch determines when to begin boost charging. There are three system conditions required before the WDCP Controller will begin an automatic boost charge (in addition to those conditions required to enable Boost Charge Dispatch, i.e., that the system is in Auto Mode 0, 1, 2, or 3 and the DC machine is not on-line):

1. Sufficient diesel capacity on-line to boost charge the batteries at maximum rate
2. No wind turbines are about to start
3. The user-specified number of days since the last complete boost charge has elapsed.

The first requirement is that there be sufficient diesel capacity on-line to charge the batteries at the maximum battery charger current. The maximum allowed battery charger current is 26 amps. This would be 7.8 kW at 300 VDC. Therefore, Statistical Boost Charge Dispatch will not initially dispatch the auxiliary battery charger unless diesel capacity on-line is at least 8 kW greater than *Diesel Capacity Required* (as determined by Diesel Dispatch).

The second requirement is that no wind turbines are about to start. This eliminates the risk of imposing the boost charge step load concurrent with the turbine start current inrush.

The last requirement is that the user-specified number of days since the last complete boost charge, called the *Boost Charge Interval*, has elapsed.

#### **4.5.2 Instantaneous Boost Charge Dispatch Criteria**

Instantaneous boost charge dispatch criteria are evaluated every PLC scan. There is only one instantaneous boost charge dispatch mode.

Instantaneous Boost Charge Dispatch determines when to end boost charging. There are two system conditions that will cause Instantaneous Boost Charge Dispatch to take the auxiliary battery charger off-line (in addition to those conditions that cause Boost Charge Dispatch to be disabled, i.e., if the system is in Manual Mode or if the DC machine is on-line):

1. Insufficient diesel capacity available to provide *Diesel Capacity Required*
2. Boost charge complete.

The first condition is if there is insufficient diesel capacity available to provide the *Diesel Capacity Required* as determined by Diesel Dispatch. Statistical Boost Charge Dispatch checks for sufficient diesel capacity on-line to boost charge at maximum rate before dispatching the auxiliary battery charger. However, this condition is not required to continue boost charging. Once a boost charge has begun, the boost charge kW becomes a *primary* load that must always be met (as opposed to a secondary load which can be turned off on/off at any time). Therefore, Diesel Dispatch will dispatch sufficient diesel capacity to continue boost charging. Even so, situations may develop in which there is no longer sufficient diesel capacity available to ensure that all the current primary loads are met. In this case, Instantaneous Boost Charge Dispatch will immediately abort the boost charge to reduce the primary load.

The second condition is if boost charge has completed. Boost Charge Control will indicate when the batteries are fully charged and it is no longer necessary to continue boost charging.

## 5 Power Flow Management

The most critical task of the wind-diesel hybrid power system is to maintain constant voltage and frequency in all modes of operation. As with any power system, this is accomplished by maintaining a balance of both real and reactive power at all times. The principles of frequency and voltage regulation are explained more fully below.

### 5.1 Frequency Regulation

The entire power system, including all its generators, distribution wiring, and even motors present in the village load, can be thought of as one big electromechanical entity, as shown in Figure 3. Power flows into this system as power from the wind transferred to the wind turbine rotor, mechanical power developed in the diesel engines as a result of combustion, and electric power drawn from the battery. Power flows out of the system to consumer resistive loads, to consumer mechanical loads, to secondary loads, and as various mechanical and electrical losses. At any given moment, if more power is flowing into the system than out of it, the difference will be stored as an increase in kinetic energy of the rotating machines within the system, both generators and motors, that happen to be on-line at that time. The effect of any power imbalance in the system is expressed in the following equation:

$$\sum P_{SOURCES} - \sum P_{SINKS} = \frac{d(K.E.)}{dt} = \frac{d}{dt} \sum_i J_i \omega^2$$

where  $P$  = active power (kW)

$K.E.$  = kinetic energy of system

$J$  = moment of inertia of rotating machine

$\omega$  = angular velocity of rotating machine

This increase in kinetic energy is manifested as an increase in rotational speed of the synchronous machines in the system and thus an increase in electrical frequency. The task of frequency regulation is essentially a problem of maintaining an instantaneous balance of the real power flowing into and out of the system.

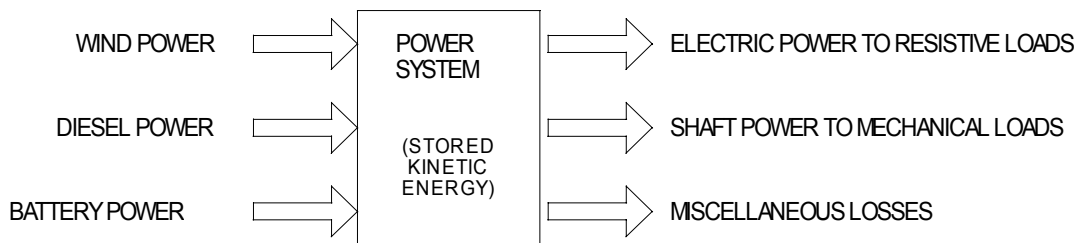

**Figure 3. Real power flows into and out of the power system**

## 5.2 Voltage Regulation

Analogously, regulating the AC voltage of the power system is a problem of maintaining equilibrium between the source and sinks of reactive power (VARs) in the system. The induction generators of the wind turbines, transformers in the distribution system, and induction motors in the consumer load are all reactive power sinks. Power factor correction capacitors on the wind turbines or the distribution system are sources of reactive power. Synchronous generators, both on the diesel gensets and on the rotary converter, can be either sources or sinks, but generally, they are supplying the reactive power demanded by the sinks.

Unlike the case of real power, where an imbalance can be absorbed by the system as a change in stored kinetic energy, there is no storage mechanism for “reactive energy.” The reactive power supplied by the sources is inherently equal to the reactive power absorbed by the sinks. This is expressed in the equation below, in which the reactive power flows for each component are expressed as functions of voltage.

$$\sum Q_{SOURCES}(V_{AC}) - \sum Q_{SINKS}(V_{AC}) = 0$$

where  $Q = \text{reactive power (kVAR)}$

$V_{AC} = \text{AC bus voltage}$

If the reactive power sources are unable to deliver the reactive power demanded by the sinks, the bus voltage will fall such that the equilibrium is maintained. With reactive power, the issue is not so much ensuring that equilibrium is maintained (which is automatic), but that the equilibrium occurs at the desired voltage level. On a synchronous machine, the function of the voltage regulator is actually to control the generator excitation such that the generator delivers the reactive power demanded by the load at the desired voltage.

## 5.3 The Power Flow Management Algorithm

There are three main power components subject to the direct control of the wind-diesel controller: the rotary converter AC machine, the rotary converter DC machine, and the secondary load controller (which actually consists of multiple distributed load controllers). Each of these devices has several different control modes associated with it. For example, the AC machine can be controlled to achieve any of the following:

- Match voltage with the AC bus (before synchronization)
- Share reactive power with the diesel generators
- Deliver a specified amount of reactive power to the grid
- Regulate AC bus voltage

The power flow management algorithm determines the appropriate control mode for each of these three devices depending on the system state. In the context of Power Flow Control, *system state* refers not only to the system operating state as defined in Section 3; it also includes additional detail such as the state of charge of the battery and the instantaneous amount of excess wind energy available.

The Wales wind-diesel hybrid power system involves multiple diesels and multiple wind turbines. In addition, there is a power converter consisting of two separate rotating machines and a secondary load that is divided into local dump load and remote dump load. Because each of these components may or may not be operating at any given time, there are a great number of possible system operating states. To develop a power flow management algorithm flexible enough to handle all possible operating states, one must identify a minimum set of key state variables that provide sufficient information to determine the appropriate control mode for each device.

Our top-level state variable is the diesel status, because it has the greatest effect on how voltage and frequency is regulated. *Diesel ON* refers to the state where one or more diesel generators is connected to the bus *and* loaded (i.e., not in load or unload ramp). Conversely, *Diesel OFF* refers to the state in which all diesel generators are either disconnected from the bus or connected but not fully loaded.

### 5.3.1 *Diesel ON State*

The stand-alone diesel generator is designed to regulate the voltage and frequency on an isolated power bus. In a multiple diesel configuration equipped with automatic load-sharing controls, the diesels collectively regulate frequency and share both the real and reactive power load in proportion to their respective ratings. Diesel gensets do an excellent job of frequency and voltage control if the real and reactive power load on them remains within their rated capacity and they are not subject to large reverse power transients. In the Diesel ON state, we allow the diesel generator(s) to perform their intended function of frequency and voltage control, and we control the rotary converter and/or secondary loads to maintain the diesel loading in a comfortable range. In summary, in Diesel ON state:

- The diesel generator(s) assume both frequency and voltage control
- Power flow to the secondary loads and/or energy storage is controlled to maintain diesel loading within a comfortable range
- The rotary converter AC machine is used to assist the diesel generators in meeting the VAR load, as necessary.

### 5.3.2 *Diesel OFF State*

In the Diesel OFF state, the only synchronous machine operating in the system is the AC machine of the rotary converter. The rotational speed of the rotary converter will establish the grid frequency. As with the diesel generator, the voltage regulator on the rotary converter AC

machine controls the field current so as to maintain the desired AC bus voltage. Frequency is controlled by modulating power flow to the secondary load or battery, depending on factors discussed below.

### **5.3.3 Other System State Variables**

Diesel status is only the first of the system state variables used in determining the appropriate control mode for the various system components. The others reflect the state of readiness of the other system components and the nature of the instantaneous real power imbalance on the system. They are embodied in the following questions:

1. Is the (rotary converter) AC machine on-line and ready?

Just as with the diesel generator, for the AC machine to be available to perform its control function, not only must its contactor be closed, but it must also not be in an unload ramp, preparing to go off-line.

2. Is the DC machine on-line and ready?

Similarly, the DC machine is only available for control when its contactor is closed and it is not in a transitional state.

3. Is there instantaneous excess wind power?

In the case where there is excess wind power, secondary (or “dump”) load may be used to provide frequency control. As long as there is excess wind power, this works fine, but suppose the wind suddenly drops, resulting in a power deficit. As wind power drops, secondary load will be rapidly removed in an attempt to maintain grid frequency. Once it has all been removed, the ability to control frequency is lost. The system must switch immediately to frequency control by the DC machine.

4. Is the battery at High State of Charge?

This question is actually several criteria rolled into one, all designed to detect when the battery state of charge (SOC) reaches a maximum desired operating level:

- Is the battery actually at a high state of charge, as determined by amp-hour integration?
- Is the DC field current limit of the rotary converter reached?
- Is the charging voltage limit of the rotary converter reached?

When any of these criteria are met, the battery is considered to be at a high state of charge, which requires that charging current be limited until the state of charge falls back below a certain level. (See Section 8 for more information on battery management.)

Note that the state variables presented above are concerned only with whether or not the various system components are on-line and ready at a particular moment in time, not when and why they are brought on-line. The criteria by which individual diesels, wind turbines, and the rotary converter AC and DC machines are turned on and off are the subject of a whole suite of dispatch algorithms, which are covered in Section 4.

#### **5.3.4 Power Flow Management Algorithm Flowchart**

The power flow management algorithm is presented in flowchart format in Figure 4. Each decision block represents one of the state variables described above. Each branch in the decision tree specifies the control mode of the devices actively participating in voltage and frequency control in the corresponding state. Note that each branch loops back to the beginning of the algorithm, because any of the key state variables can change at any moment.

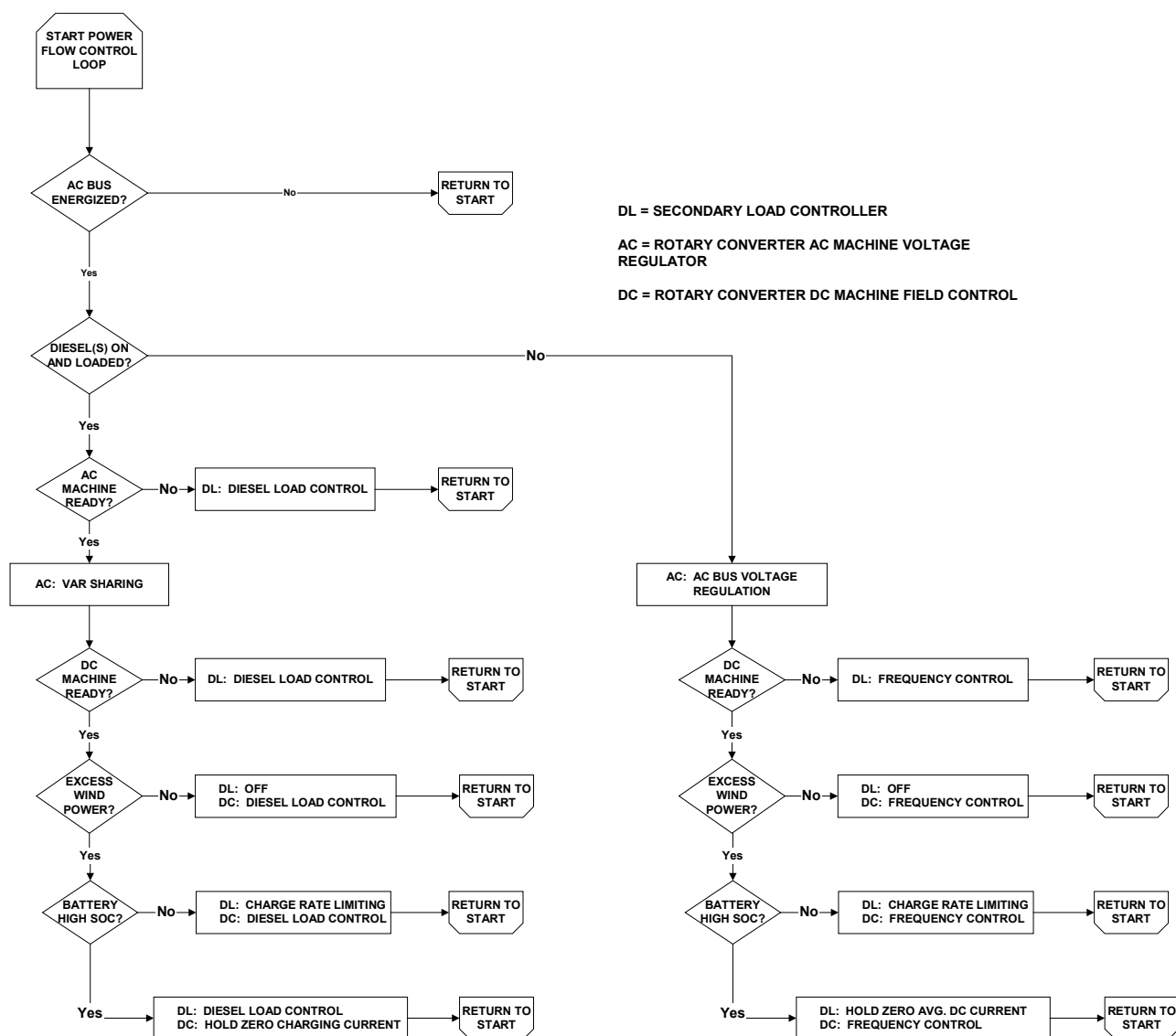

**Figure 4. Power flow algorithm**

In the Wales wind-diesel control system, the loop shown in Figure 4 is executed approximately once every 40 milliseconds (ms). A short loop interval is necessary to detect and immediately respond to changes in component status. For example, when the last diesel goes off-line, the rotary converter must step in immediately to control the grid frequency and voltage. If the transition is too slow, unacceptable deviations of either voltage or frequency could result.

When a change in state occurs that calls for a change in the control modes of one or more devices, it is important that the mode changes occur seamlessly, without causing discontinuities in power flow, which would be manifested as frequency or voltage transients on the line. This requirement is not expressed in the flowchart, but it is an important part of the design of the various control modes and requires careful application of bumpless transfer techniques.



## 6 Diesel Load Control

As discussed in Section 5, bus frequency is controlled by the diesel generator(s) whenever one or more of them is on-line. During diesel-on operation, secondary load (which may be dump load or power to charge the battery) is used to maintain the total diesel load at the diesel load set point if the diesel load would otherwise fall below it. Diesel Load Control is the software module in the Wind-Diesel Control Panel PLC program that continually calculates the amount of secondary load required to maintain the diesel load at the set point.

Diesel Load Control uses the PLC's built-in proportional-integral-derivative (PID) loop feature to perform this calculation. PID control loops have two inputs, the *set point* and the *process value* (the quantity that one is trying to control), and one output, the *control output*. The controller changes the control output in an attempt to minimize the *error*, which is the difference between the set point and the process value. In this case, the set point represents the desired diesel kW load, the process value is the actual measured diesel kW load, and the control output is the *Secondary Load Request*.

### 6.1 The Diesel Load Set Point

In most cases, the diesel load set point will be based on the minimum allowed diesel % loading, which is a user-settable parameter based on the engine manufacturer's recommendations. Cummins recommends for the LTA10 engines that the genset be loaded so as to maintain an exhaust temperature of at least 650°F. Experience in Wales indicates that this is achieved when the genset is operated at 20-25% of rated load.

There is another diesel loading criterion that may override the minimum allowed diesel % loading, which is based on diesel plant heat required. There is a certain amount of heat required to keep the plant warm and the non-operating diesel engines at a sufficiently high temperature to provide for rapid starting and synchronization. The plant heat requirement is calculated as the sum of (1) the heat required to keep the diesel engines hot given a plant indoor temperature of 70°F, and (2) the additional heat required to keep the plant at 70°F given the existing outdoor ambient temperature.

Plant heat is supplied through a combination of diesel jacket water heat and electric energy sent to the local dump load boiler. There are situations when the wind and the village load are such that the available wind power, in combination with the diesel running at minimum allowed load, is just enough to meet the village load. When the ambient temperature is very low, the heat supplied by the diesel running at minimum allowed load might be less than the plant heat required. In that case, the diesel load set point is increased until the plant heat produced, counting both jacket water heat and local dump load heat, equals the calculated plant heat required. Note that the jacket water heat is estimated as being equal to the electric output of the diesel generator.

## 6.2 Diesel Load Control Modes

PID control uses three parameters to define the control function: proportional gain, integral gain, and derivative gain. In industrial PID controllers, the integral and derivative gains are often reformulated as integral and derivative time constants, often referred to as *reset* and *rate*, respectively. Tuning the control loop consists of determining the optimal values for each of these three parameters, which will depend on the dynamics of the system. The dynamics of the Wales power system depend on the response characteristics of the grid (the system being controlled) and the response of the device being used to control it. In the case of diesel load control, the system response depends primarily on which large rotating machines are on-line at any given time. The actuator response depends on whether the dump load or the DC machine is being used to provide the secondary load necessary to maintain diesel load.

Considering the multiplicity of diesels and wind turbines, it would be overly complex to provide a different control loop tuning for every possible combination of machines on-line. As a reasonable compromise, we have defined four different control modes (sets of control gains) to correspond to the following four system states:

- 1) Dump Load Diesel Load Control – AC Machine Off
- 2) Dump Load Diesel Load Control – AC Machine On, DC Machine Off
- 3) Dump Load Diesel Load Control – AC Machine On, DC Machine On
- 4) DC Diesel Load Control - AC Machine On, DC Machine On.

## 7 Nondiesel Power Component Control

This section deals with the specifics of how each of the nondiesel power components is controlled. These components are the dump loads (electric boilers), the AC machine side of the rotary converter, and the DC machine side of the rotary converter.

### 7.1 Dump Load Control

As discussed in Section 6, Diesel Load Control is strictly a computational block that determines the amount of secondary load required. Whether the *Secondary Load Request* is met using dump load or by charging the battery is determined by the Power Flow Management algorithm, discussed in Section 5. Diesel Load Control is just one of several possible control modes for the dump load. Dump Load Control refers to the PLC software module that actually controls the local and remote dump loads. Dump Load Control has three aspects:

- 1) Determine how much total dump load is required.
- 2) Determine the appropriate allocation between local and remote DL dump load.
- 3) Issue the actual switching commands to control individual boiler elements.

#### 7.1.1 Determining Dump Load Required: Dump Load Control Modes

There are several different modes of Dump Load Control, depending on the control objective at any given time. Each of these uses a different method and/or different criteria for calculating the amount of dump load required moment by moment. The three modes are Diesel Load Control, Frequency Control, and Battery Charge Current Control.

The Diesel Load Control mode of Dump Load Control is active when the dump load is being used to satisfy the *Secondary Load Request* as determined by the Diesel Load Control module. In this mode, Dump Load Required is simply set equal to the *Secondary Load Request*. This is known as *pass-through*, because the output from another computational block is simply passed through to the output of this one, without additional modification.

The Frequency Control mode of Dump Load Control is active only in diesel-off operation when the DC machine is also off-line, which would normally only be the case if the DC machine were unavailable. In this state, the system is essentially a high-penetration no storage wind-diesel system. This control mode uses a built-in PID loop in the RCCC PLC. The set point of this PID loop is the desired bus frequency. The default value for this set point is 60 Hz. The process value (feedback) for the PID loop is the grid frequency, as measured by the magnetic pickup on the DC machine.\*

---

\* Though the DC machine is not on-line in this mode, it is part of the rotary converter and therefore still spinning. Because the AC machine is a synchronous generator, its rotational speed is exactly proportional to the grid frequency.

The Battery Charge Current Limiting mode of Dump Load Control is active when the DC machine is on-line, the battery is not full, and there is excess wind power available. In this situation, excess power is used to charge the battery, but the charge current must be kept from exceeding the maximum allowed charging current. This control mode uses a built-in PID loop in the RCCC PLC. The process value for this loop is the measured DC armature current. The default set point value is 260A, which represents the  $2C_5$  charging rate. If the DC current starts to exceed this value, dump load will be applied so as to regulate the current at the set point value. If excess power drops such that the battery current drops below the set point, any on-line dump load will be removed, but otherwise there is no consequence.

The Battery Charge Current Control mode of Dump Load Control is active in diesel-off operation, with the DC machine on-line, when there is excess wind power and the battery is full. This is the same as the Battery Charge Rate Limiting Mode, except that the set point is zero A instead of 260 A. Because the DC machine is busy controlling bus frequency, there will inevitably be current fluctuations in and out of the battery. The dump load control, however, will act to minimize these fluctuations and center them around zero amps, so that the net flow into the battery is zero.

### **7.1.2 Local/Remote Dump Load Apportionment**

Once the total dump load required is known, the controller must determine the appropriate split between local and remote dump load. This is done with the following considerations in mind:

- Ensuring that the plant has sufficient heat is a higher priority than supplying excess heat to the school.
- No more excess power should be sent to the local dump load than is necessary to keep the plant and engines warm.
- Fast response and high-resolution dump load control is only obtainable with the local dump load. Therefore, whenever any dump load is required, for either diesel load control or bus frequency control, the local dump load must be kept within a range that allows for controllability. Remote dump load must be adjusted to prevent the local dump load from either going to zero or reaching its maximum capacity. Hitting either extreme could result in short control dropouts or a complete loss of control.

Apportioning total dump load between the local and remote dump loads is based on two parameters, the Local Dump Load Target Value and the Local Dump Load Deadband. The Local Dump Load Target Value represents the desired average kW value to be maintained by the local dump load, which, in turn, is the amount of heat that when added to the diesel jacket water heat will equal the total plant heat required. The Local Dump Load Deadband is the width of the power band, centered around the target value, within which the local dump load will be allowed to vary before making a change to the amount of power sent to the remote dump load.

The local dump load target value is calculated as follows:

*Local Dump Load Target Value = Min[Max( 20 kW, Required Dump Load Contribution to Plant Heat), 69 kW]*

where

*Required Dump Load Contribution to Plant Heat = (Plant Heat Required) – (1 minute average Total Diesel kW)*

Note that the Local Dump Load Target Value is constrained to be between 20 and 69 kW. The upper limit is 20 kW less than the capacity of the local dump load.

The Local Dump Load Deadband is set at 30 kW, which is slightly larger than the remote dump load element size of 24 kW. This deadband defines the local dump load upper and lower limits, equidistant above and below the target value. Regardless of which dump load control mode is active (see Section 7.1.1), whenever the local dump load power level reaches one of the limits, the control system will attempt to add or remove a remote dump load element as appropriate. As shown in Figure 5, when the local dump load reaches the upper limit, a remote dump load element will be added if it is available, thereby keeping the local dump load within the deadband. Similarly, when the local dump load reaches the lower limit, a remote element will be removed, assuming there is one on to be removed. With random variations in dump load required, this approach will ensure that the average local dump load is approximately equal to the local dump load target value.

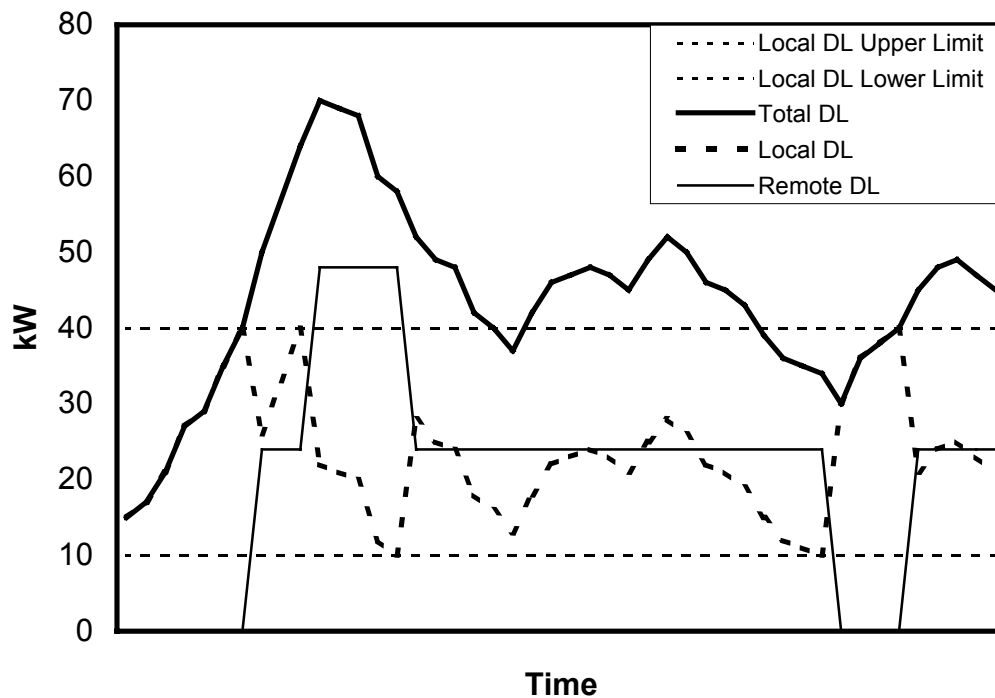

**Figure 5 Interplay between local and remote dump load as total dump load required varies. (Target local dump load = 25 kW.)**

As remote dump load elements are added and removed, the amount of local dump load commanded is simultaneously adjusted by an amount equal to the remote dump load step size. Thus, the local/remote apportionment process is completely transparent to the overall dump load control, and the total dump load on the system smoothly varies according to the calculated Dump Load Required.

### **7.1.3 Dump Load Element Switching**

Both diesel load control and dump load frequency control require a dump load with fast response and good resolution. The local dump load provides fast response using a high-speed communications link to the RCCC PLC and solid-state relays to switch the elements. It provides good resolution with its sizing of the heating elements in a binary progression. The local dump load boiler is equipped with six heating elements of the following nominal sizes: 2.5, 5, 10, 20, 20, and 20 kW. Two of the 20-kW elements are combined to form a 40-kW virtual element and are always switched on or off simultaneously. Thus, the local dump load is organized as a five element binary progression: 2.5, 5, 10, 20, and 40. By switching these elements appropriately, any power level from zero to the full nominal value of 77.5 kW may be obtained with 2.5-kW resolution.\*

The remote dump load does not have the same requirement for fine resolution as the local dump load. Instead of a binary array of elements, it consists of six equal-sized elements, which has several advantages. Using equal-sized boiler elements and equal-sized, solid-state relays to switch them reduces the number of spare parts required. In addition, this approach lends itself to the future integration of additional remote dump loads, in the community water treatment plant, for instance. In that case, the additional dump load would simply appear to the system as an extension of a linear array of heating elements.

The criteria for switching remote dump load elements in or out are described in Section 7.1.2. The actual switching of particular elements is based on a FIFO scheme. When an additional element of remote dump load is needed, the next available off element is turned on. When it is necessary to remove an element, the element that has been on the longest is turned off. This approach ensures equal duty on all of the boiler elements and solid-state relays. If an individual element has been disabled by the operator (or automatically by the control system), that element will be skipped over and the next available element turned on instead.

---

\* Because the boiler elements differ slightly from their nominal values, and because the system voltage is higher than the voltage at which the elements are rated, the actual step size is approximately 2.875 kW, and the total local dump load capacity is approximately 89 kW.

## 7.2 AC Machine Control

*AC Machine Control* refers to the processes of starting and stopping the AC machine and controlling it to perform a specific task while on-line. Four outputs control the operation of the AC machine:

<b>Pony motor drive contactor close signal</b>	Closes the AC contactor to energize the pony motor variable-speed drive.
<b>Pony motor drive enable signal</b>	Causes the variable-speed drive to accelerate the pony motor and match the frequency of the rotary converter to the measured bus frequency.
<b>Voltage regulator bias signal</b>	Biases the set point of the AC voltage regulator that controls the field current in the AC machine.
<b>AC Machine contactor close signal</b>	Connects the AC Machine to the plant bus.

The following sections describe how these four control outputs are used to control the AC machine during the various phases of its operation.

### 7.2.1 AC Machine Startup Sequence

Once the controller makes the decision to dispatch the AC machine, it runs a startup sequence to bring it on-line.

1. Close the pony motor drive contactor and enable the drive to accelerate the rotary converter to synchronous speed. The pony motor variable-speed drive attempts to match the rotary converter speed/frequency to that of the grid. A frequency transducer on the plant bus is used for the set point of the pony motor speed control loop. A frequency transducer on the magnetic pickup (MPU) signal from the DC machine is used as the speed feedback to this control loop. Note that the pony motor drive only attempts to match speed. It does not attempt to bring the AC machine voltage in phase with the bus voltage.
2. Adjust the voltage regulator bias signal such that AC machine armature voltage matches the measured bus voltage.
3. When the AC machine voltage and frequency are in the right range, issue the AC contactor close command.
4. When the AC machine frequency, voltage, and phase match the bus within specified tolerances, the sync check relay in the Basler Generator Protective Relay (GPR) actually allows the AC contactor to close. When the AC contactor closes, the pony motor drive contactor opens.
5. Place the AC machine in kVAR Control Mode, with a zero set point. This mode will bias the voltage regulator such that there is no net reactive power flow in or out of the AC machine. In other words, it will be held at unity power factor.

### **7.2.2 On-Line Control Modes of the AC Machine**

There are three on-line control modes for the AC machine:

#### kVAR Control

In this mode, the voltage regulator set point is biased as necessary to maintain a fixed value of kVAR output by the AC machine. It is used only to maintain zero kVAR during the AC machine startup and shutdown sequences.

#### Reactive Power Sharing

In this mode, the voltage regulator is biased so that the AC machine shares the total reactive load with any on-line diesels, with each machine sharing in proportion to its kW rating. The total reactive load on the power system consists of the kVAR component of the village load plus the reactive power consumed by the wind turbines. Note that when multiple diesel generators are on-line, they share reactive load automatically using the cross-current compensation method. The AC machine is not part of the cross-current compensation loop. Its kVAR output is actively controlled by the RCCC PLC.

#### Bus Voltage Control

This mode is only used when no diesel generators are on-line. In this mode, the AC machine's voltage regulator is responsible for controlling the plant bus voltage. Its set point is biased only as necessary to compensate for changing load conditions or drift in the voltage regulator. The operator is able to change the plant bus voltage set point from the RCCC touchscreen. Note that this setting only applies in diesel-off mode.

### **7.2.3 AC Machine Shutdown Sequence**

Once the controller makes the decision to no longer dispatch the AC machine, it runs a shutdown sequence to take it off-line.

1. Enter the kVAR Control Mode and ramp the set point to zero kVAR. This minimizes the current flow in the AC machine, allowing for a softer opening of the contactor. The current cannot be brought to zero, because a certain amount of real power is required to keep the rotary converter spinning.
2. When the kVAR drops below a specified threshold, open the AC contactor.
3. When the contactor opens, the rotary converter coasts down to a stop.



### 7.3 DC Machine Control

*DC Machine Control* refers to the processes of starting and stopping the DC machine and controlling it to perform a specific task while on-line. Four outputs control the operation of the DC machine, as shown in the following table:

<b>Field power supply enable signal</b>	Energizes the DC field current power supply
<b>Load resistor contactor close signal</b>	Connects the dummy load resistor to the output of the field current DC power supply
<b>Speed control bias signal</b>	Biases the set point of the speed control, which in turn, controls the set point of the field current power supply
<b>DC Machine contactor close signal</b>	Connects the DC Machine to the battery

The rotary converter can be thought of as an additional genset. Rather than a diesel engine, the DC machine acts as the prime mover. The AC machine is a synchronous generator. The difference is that the rotary converter is bidirectional, i.e., it can absorb as well as generate AC electric power. Figure 6 shows the means by which the DC machine is controlled. Because the primary function of the DC machine is frequency control in diesel-off mode, a standard Woodward generator speed control is used as the main control component for the DC machine. Normally the output from the speed control would be connected to the fuel system actuator on an engine. In this case, the speed control output adjusts the set point of the DC field current power supply. By controlling the DC machine field current, the DC machine torque is controlled over its full operating range. When producing positive torque, the DC machine is a motor, driving the AC machine and generating AC power, but discharging the battery. When producing negative torque, the DC machine is a generator, charging the battery but causing the AC machine to act as a motor.

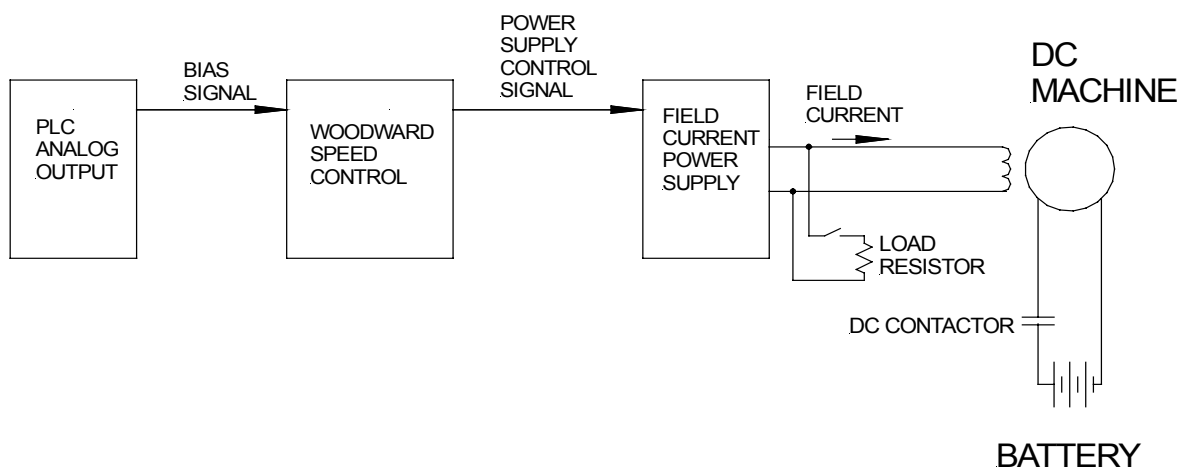

**Figure 6** Layout of DC machine control

Just as the set point of a diesel speed controller is often biased to perform load-sharing with other diesels or base-loading to a utility, the analog bias signal from the PLC to the speed controller allows the speed control to perform control functions other than pure frequency control, such as battery charge regulation. These control modes are explained in Section 7.3.2.

### 7.3.1 DC Machine Startup Sequence

Once the controller makes the decision to dispatch the DC machine, it runs a startup sequence to bring it on-line. Note that this startup sequence is not initiated until the rotary converter is spinning at synchronous speed and the AC machine is on-line.

1. Connect the DC voltage transducer to the battery and measure the battery voltage.
2. Switch the DC voltage transducer to the DC armature.
3. Turn on the DC field current power supply.
4. Connect a load resistor to the field power supply output for several seconds to establish current flow through the silicon control rectifiers (SCRs). This step is necessary because of the very high inductance of the DC field coil. The impedance of the coil is so high that without an additional load across the output of the power supply, current will not build up enough to hold the SCRs on after the initial turn-on pulse.
5. Adjust the speed controller set point bias signal such that the DC armature voltage matches the battery voltage.
6. Close DC contactor when the voltage difference drops below a specified threshold.
7. Enter DC Current Control Mode with a zero set point. This is a standby mode in which the DC machine is connected to the battery, but no current flows in either direction. (The power to keep the rotary converter spinning comes from the AC bus.)

### 7.3.2 On-Line Control Modes of the DC Machine

There are three on-line control modes for the DC machine:

#### *DC Battery Charging Current Control*

In this control mode, the speed control's set point is biased to regulate the DC current. This mode is normally only used when ramping the DC current to zero as part of the DC machine shutdown sequence. This mode is also used to control the battery discharge rate during a battery capacity test.

#### *DC Power Control*

In this control mode, the speed control's set point is biased to control the DC power sent to the battery. This mode is used when Diesel Load Control is in the DC Diesel Load Control Mode (see Section 6.2).

### *Bus Frequency Control*

Whenever the DC machine is on-line and the system is in diesel-off operation, the DC machine is responsible for controlling the bus frequency at 60 Hz. Because this is the basic function of Woodward speed control, this control mode requires no outer control loop and no speed control set point bias signal. Thus, it is the most straightforward of the DC machine control modes. There are no PID gains in the PLC associated with this control mode. The DC machine bus frequency control dynamics depend solely on the parameters programmed directly in the Woodward speed control.

#### **7.3.3 DC Machine Shutdown Sequence**

Once the controller makes the decision to no longer dispatch the DC machine, it runs the following shutdown sequence to take it off-line:

1. Enter the DC Current Control Mode and ramp the set point to zero amps. This provides for a soft opening of the DC contactor.
2. When DC current drops below a specified threshold, open the DC contactor.
3. De-energize the field current power supply.
4. When the DC machine goes off-line, the rotary converter reverts to acting as a synchronous condenser.

## 8 Battery Management

### 8.1 Battery Characteristics

The Wales system battery bank consists of 200 Ni-Cd cells, each having a nominal voltage of 1.2 VDC, giving a total nominal battery voltage of 240 VDC. The cells have a C<sub>5</sub> (5-hour discharge rate) rated capacity of 130 ampere-hour (Ah). Thus, the nominal energy storage capacity of the battery bank is 240 VDC x 130 Ah = 31.2 kWh. Because the discharge rates will often be higher than the C<sub>5</sub> rate, and because it is not desirable to operate the battery at either very high or very low states of charge, the actual usable capacity of the battery will be significantly less, perhaps 40-50% of nominal. If the actual usable battery capacity is 40% of 31.2 kWh, or 12.5 kWh, the rotary converter could deliver 50 kW (less converter losses) to the AC bus for approximately 15 minutes. Although the energy storage is of short duration, it can significantly improve the operating performance of the system.

The terminal voltage of any battery is a function of the battery temperature, the charging (or discharging) current, and the battery's state of charge (SOC). It is also a function of the battery's recent charge history, the path by which it got to its current state. However, the battery management algorithms employed in the wind-diesel control software neglect any charge history effects.

The general relation between battery voltage and state of charge during constant current charging is shown in Figure 7. Starting with a completely discharged battery, the voltage initially rises rapidly. As charging continues, the voltage increases slowly and nearly linearly with increasing state of charge. When the battery approaches a high state of charge, the voltage rises rapidly and then plateaus at a high level. Continued charging at this stage results in very little additional stored energy. Most of the input energy is dissipated as battery gassing. The "knee" in the charging curve typically occurs at 80-90% state of charge. Increasing the charging current shifts the knee to the left (to a lower SOC) and upward (to a higher voltage).

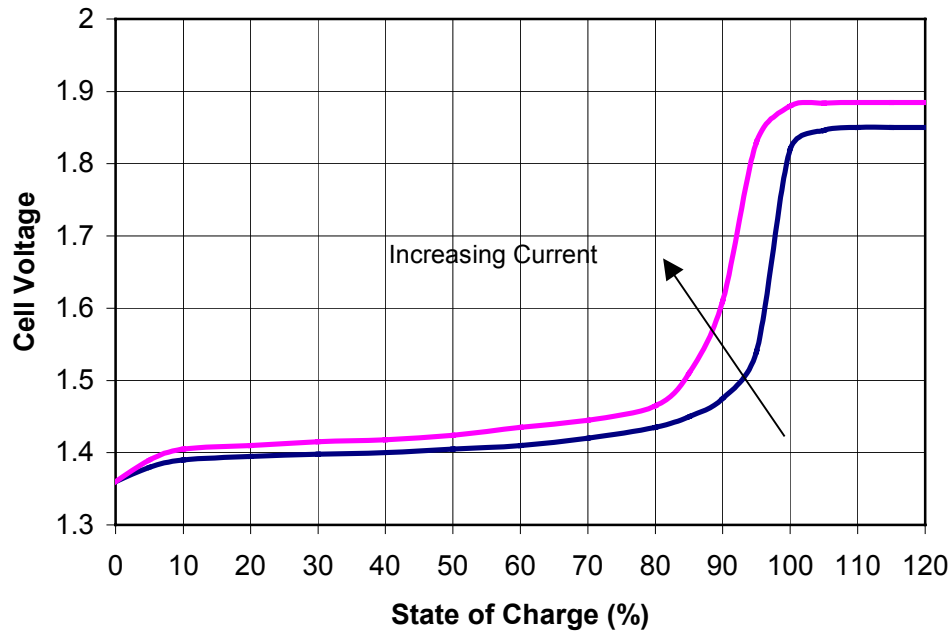

**Figure 7 Constant current charging voltage vs. SOC**

The general relation between battery voltage and the depth of discharge (DOD) during constant current discharging is shown in Figure 8. Starting with a completely charged battery, the voltage initially falls rapidly. As discharging continues, the voltage decreases slowly and nearly linearly with increasing depth of discharge. When the battery approaches a low state of charge, the voltage falls off steeply. A cutoff voltage is typically defined as that at which the battery is effectively empty, even though it has not delivered its rated capacity. The knee in the discharging curve typically occurs at 95% state of charge at the rated discharging current. However, increasing the charging current shifts the knee significantly to the left (to a lower DOD) and downward (to a lower voltage).

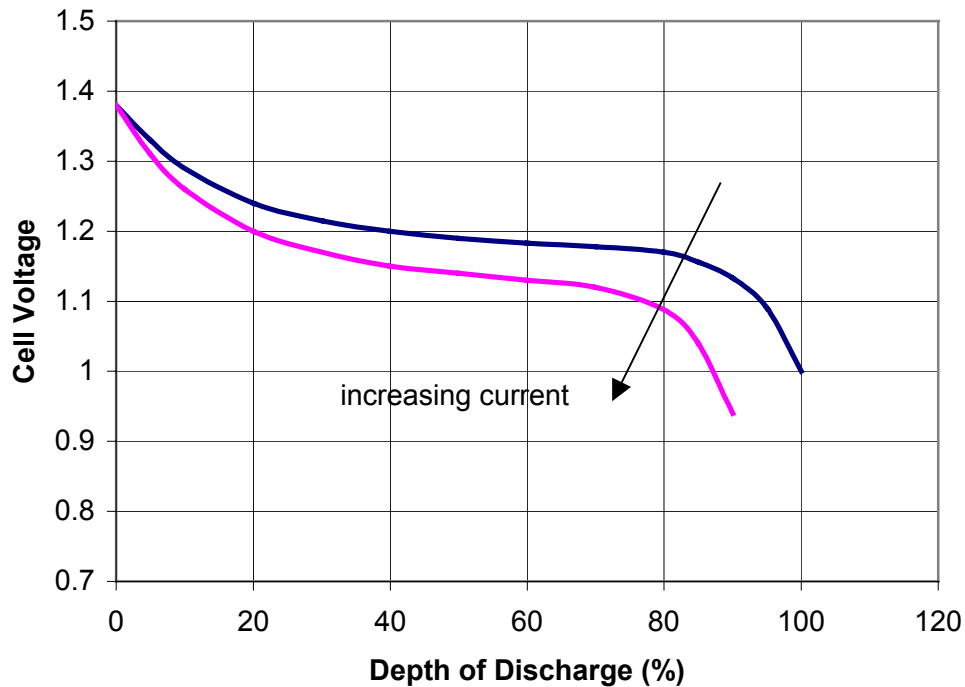

**Figure 8 Constant current discharging voltage vs. DOD**

## 8.2 State of Charge Tracking

Accurately measuring the SOC of a battery is very difficult and generally requires special instrumentation. It is possible, however, to obtain a reasonable estimate of SOC by starting with a known state of charge and integrating all subsequent ampere-hours in and out of the battery. The longer this integration is performed, the more error will accumulate in the SOC estimate, so it is important to regularly reset the amp-hour count to correspond to a known SOC. In this context, *known* can mean estimated based on some other method besides amp-hour integration.

The wind-diesel system controller uses the amp-hour integration method to provide a continuous estimate of battery SOC. Battery SOC is calculated mainly to provide the operator an approximate indication of the SOC of the battery. The estimated SOC is also used to reset certain battery status flags, as will be described in the next section. It is not directly used to define acceptable limits on battery charging. Determining the normal operating limits on battery charging is a dynamic process that will be described in the following sections.

### 8.3 Battery Status Flags

The control system defines four battery status flags that indicate when certain points on the battery charge and discharge curves are reached, as described in the following table:

**Table 5. Definition of Battery Status Flags**

High SOC	Corresponds to the knee in the battery-charging curve (see Figure 7), i.e., the point at which the battery voltage starts to rise rapidly.
Battery Full	Corresponds to the point, during constant current charging, where the voltage stops increasing.
Low SOC	Corresponds to the knee in the battery-discharging curve (see Figure 8), i.e., the point at which the battery voltage starts to fall rapidly. This occurs when there is approximately 10% usable battery capacity remaining at the present discharge rate.
Battery Empty	Corresponds to the point at which there is less than 2% of usable battery capacity left at the present discharge rate.

In a wind-diesel hybrid system, the battery current may be continuously changing, even changing from charging to discharging and back again within a short time. Thus, the battery may be continuously operating on a different characteristic charging or discharging voltage versus SOC curve. It is therefore difficult to detect when the battery is on the knee of a curve. As stated earlier, instantaneous terminal voltage for a given battery is a function of battery temperature, current, and SOC. We have previously analyzed the family of charge and discharge curves and come up with formulas approximating voltage at which the battery will reach three of the four points defined above (High SOC, Low SOC, and Battery Empty, for any combination of battery current and temperature.\* These formulas take the following form:

$$V_X(I, T) = V_{X,0} + k_I \frac{I}{C_5} + k_T(T - 68),$$

where

$V_X$  = voltage corresponding to criteria X, e.g., High SOC

$V_{X,0}$  = uncorrected threshold voltage for criterion X

---

\* The “Battery Full” criterion is based on charging voltage stabilization and will be explained in the section on boost charging.

- $k_I$  = current correction factor (volt/hour)  
 $k_T$  = temperature correction factor (volt/°F)  
 $C_5$  = nominal battery capacity (Ah)  
 $I$  = battery current (A). (Charging is positive, discharging is negative)  
 $T$  = battery temperature (°F)

In addition to the voltage criteria, there are secondary criteria for setting the High SOC and Low SOC flags. These are based on the status of the field coil of the DC machine. The battery current, whether charging or discharging, is controlled by controlling the current in the DC machine field coil. Raising this current will increase the battery current; decreasing the field current decreases the battery charging current (or increases the discharging current). At a high SOC, it requires more field current to achieve the same battery charging current. Conversely, at a low SOC, it requires a lower field current to achieve the same battery discharging current. There are upper and lower limits on DC field current that must be respected. There is also a maximum field coil operating temperature. Thus, there are field coil current and temperature criteria for setting the High SOC and Low SOC flags. These secondary criteria serve as a backup to the primary voltage criteria.

In the previous section, it was mentioned that the running estimate of battery SOC based on amp-hour integration must periodically reset based on some other indication of SOC. The battery status flags are used for this purpose. Because the knee in the charging curve tends to occur near 85% state of charge, the SOC register is arbitrarily reset to 85% whenever the High SOC flag is set. The amp-hour integration then proceeds from the new value. Similarly, whenever the Battery Full flag is set, the SOC register is reset to 100%.

The battery status flags are used in various power flow and component dispatch decisions. It is therefore important to reset them when they no longer apply. For example, once the battery discharges a certain amount after reaching a high SOC, the High SOC flag is reset. Similarly, once the battery charges a certain amount after the Low SOC flag is set, that flag will be reset. Table 6 summarizes the conditions for setting and resetting the battery status flags.



**Table 6. Battery Status Flag Setting/Resetting Criteria**

Battery Status Flag	Criteria for Setting	Criteria for Resetting
High SOC	$V_{\text{battery}} \geq V_H(I,T)$ Or High field current limit reached Or High field coil temperature limit reached	SOC < 75%
Battery Full	$dV/dt = 0$ during boost charge Or Calculated SOC reaches 100% not during boost charge	SOC < 85%
Low SOC	$V_{\text{battery}} < V_L(I,T)$ Or Low field current limit reached	SOC $\geq$ [(SOC when Low Limit was set) + 20%]
Battery Empty	$V_{\text{battery}} < V_E(I,T)$	SOC $\geq$ [(SOC when Battery Empty was set) + 20%]

#### 8.4 Normal Charging and Discharging

The two main operating modes of the DC machine are frequency control (when the diesel is off) and diesel load control (when the diesel is on). In both of these modes, the battery continuously absorbs or delivers as much power as demanded by the DC machine. Battery current varies continually and somewhat randomly. Thus, battery charging and discharging is essentially unregulated. The only exception to this is that the battery charging current is limited to 260A, which is twice the  $C_5$  rate. If the battery is called on to absorb so much excess wind power that the charging current starts to exceed this limit, dump load is increased to limit the battery current.

The battery management strategy is to operate the battery in a SOC range bounded on the upper end by the knee in the charging curve and on the lower end by the knee in the discharging curve. We believe that this strategy will provide the highest energy storage efficiency and the lowest rate of wear on the battery. Typically, the normal SOC operating range will be about 20 to 85%, but, in fact, the limits will vary depending on the prevailing charging and discharging currents.

## 8.5 Boost Charging

Most batteries require a periodic boost charge, sometimes called *equalization charge*, to maintain full capacity. Lead-acid batteries must be brought to a state of full charge fairly frequently. Ni-Cd batteries do not require a boost charge nearly as often, but the manufacturer nevertheless recommends that the procedure be performed several times a year. In accordance with the battery management strategy described above, normally the battery goes no higher than approximately 85% SOC. The only time the battery is brought to 100% SOC is during a boost charge.

Boost charging is performed using the constant current charging method, which is the only charging method that will bring a Ni-Cd battery to a full state of charge in a reasonable period of time. When a constant charge current is applied, the battery voltage will stabilize at approximately 1.85 volts/cell. During the boost charge, the battery voltage is monitored. When battery voltage stabilization occurs, the boost charge is terminated.

## 9 Fault Detection and Handling

The Wales wind-diesel hybrid system is designed to generate power with high reliability. In a complex system, high reliability implies more than minimizing the failure rate of the various system components. It also implies an extensive system self-diagnostic capability, so that when component faults and other abnormal conditions do occur, they can promptly be detected, and the system can respond appropriately. Specifically, such capabilities should include the following:

- If a particular component fails, the system should have sufficient operational flexibility that the component can be isolated and the system continue operating without it, perhaps in a more basic configuration. Systems with this capability are often referred to as *robust* or *fault tolerant*.
- The system should provide sufficiently detailed annunciation of faults or other abnormalities so that the system can be repaired rapidly and cost-effectively with a minimum of troubleshooting.
- The system should provide early indication of degraded component performance to alert the operator and service personnel of a potential problem or imminent failure. Timely attention to such indications can avert an actual component failure and possible disruption of service.

The foundation for these capabilities in the wind-diesel control system is the fault detection and handling scheme. All faults occur in, or are at least associated with, a particular component or subsystem. For each component, therefore, we attempt to identify all possible faults or other abnormal conditions. These are divided into three categories, *cautions*, *warnings*, and *alarms*, which indicate different levels of urgency and initiate different system responses.

A *caution* indicates that a particular monitored quantity is outside of its normal operating range and indicates a need for service and/or adjustment of the affected component. The system does not respond to a caution other than to annunciate the condition on the operator interface. The condition poses no immediate danger, and the component will continue to be available for dispatch. It is up to the operator and/or service personnel to investigate the condition and determine if any special action is warranted. Cautions are annunciated on the operator touchscreen by blue indicator lights.

A *warning* indicates that a particular monitored quantity is outside of acceptable operating limits. Continued operation at such levels could lead to component damage and/or power system failure. The system responds to a warning by performing a controlled shutdown of the affected component. If it is a power-generating component, sufficient replacement generating capacity is brought on-line before the component is taken off-line. The affected component becomes unavailable and remains so until the precipitating condition is removed and the warning cleared. Warnings are annunciated on the operator touch screen by yellow indicator lights.

An *alarm* indicates a severe malfunction that poses an immediate danger to personnel and/or equipment. The system responds by immediately disconnecting and shutting down the affected component without regard for the ability of the remaining components to meet the primary load. An alarm condition is by definition sufficiently serious that it is preferable to risk a power outage than to allow the component to remain on-line. The affected component becomes unavailable and remains so until the precipitating condition is removed and the alarm cleared. Alarms are annunciated on the operator touch screen by red indicator lights.

Except for a few special cases, all cautions, warnings, and alarms must be reset by the operator. This ensures that the operator is aware of the occurrence, even if it requires no special service or repair action in response.

## 10 Data Logging and Reporting

The Wales system is the first high-penetration, wind-diesel system deployed to power an entire arctic village. Because it is a technology demonstration project and can serve as the basis for replication to many other Alaskan villages, careful monitoring and reporting of system performance is essential. To meet this need, a complete suite of software modules has been created to perform data acquisition, logging, transfer, decoding, analysis, and reporting. The entire data flow, from its acquisition in the PLC to its eventual reduction to summary report is depicted in Figure 9.

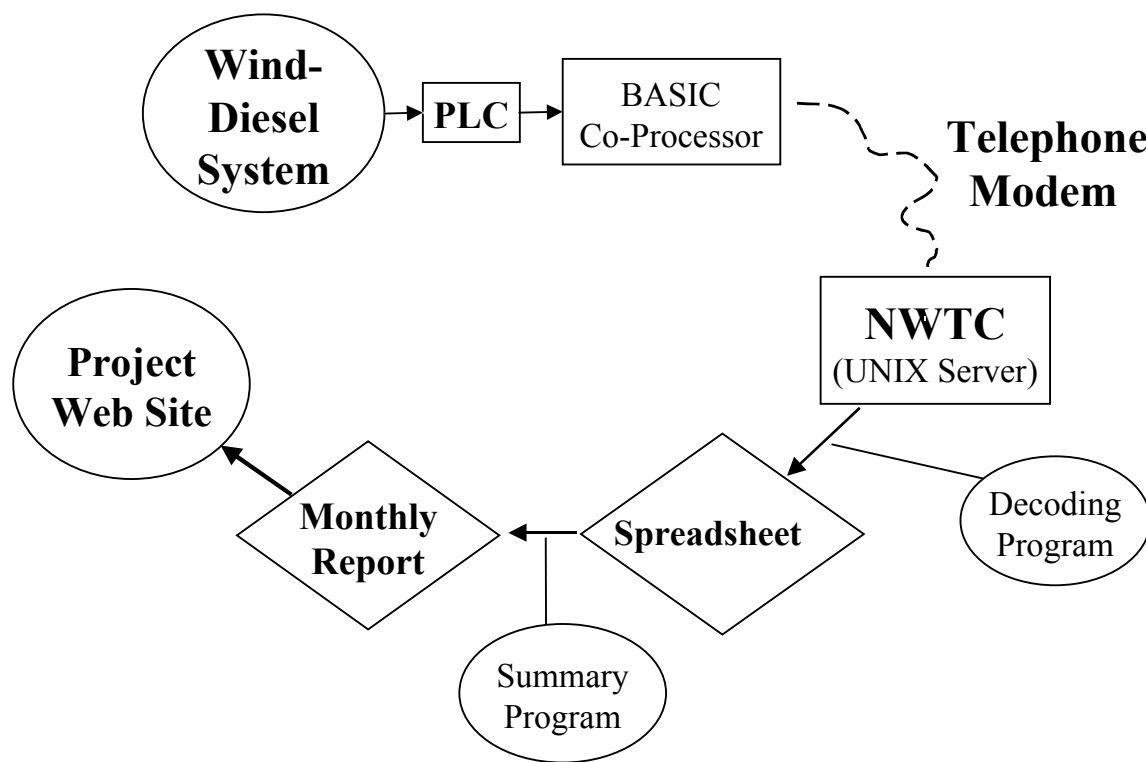

**Figure 9. System data logging, reducing, and reporting**

### 10.1 Data Acquisition, Logging, and Transfer

Data acquisition and logging capability is incorporated into the design of the control system. In an attempt to ensure the integrity of the data, the system was designed to be completely automatic, not requiring any local operator action. The PLC in the Wind-Diesel Control Panel monitors all energy flows, status relays, and alarm relays for all of the major system components. Because we wish to be able to look retroactively at how the system behaved during a given

period of operation, the data logging system is designed to preserve a detailed time history of hybrid system operation. To reduce the operating data to a manageable amount, all numerical quantities are stored as 10-minute averages in the PLC. To reduce the memory and computational overhead in the PLC central processing unit (CPU), the tasks of assembling and uploading the performance data files are handled by a BASIC coprocessor module, which occupies a slot in the PLC backplane. At the end of every data averaging interval, a data record consisting of all averaged quantities and a snapshot of all important status and alarm relays is copied from the CPU to the coprocessor module, where the records are assembled into a time-series data file. The data are stored in a hexadecimal (hex) format to conserve memory and reduce transmission time. The coprocessor module, via a serial port connected to a modem, periodically establishes a dial-up connection with a UNIX server at the National Renewable Energy Laboratory in Boulder, Colo., and uploads the accumulated data. Because of the large amount of data collected and the limited amount of memory available in the coprocessor, the upload must be performed once a day.

While the PLC is capable of recording, storing, and sending information on every aspect of the wind-diesel system, this makes up only half of the overall performance monitoring process. When this data is uploaded to a server, it still must be decoded, analyzed, and reduced to a form that a person can look at and easily interpret. The software programs to perform the data decoding and analysis had to be developed for this specific application.

## 10.2 Data Decoding

When the hex data are received by the NREL server, it is first converted back into its appropriate format. For instance, some of the hex characters represent text values, such as the date the information was recorded. Other characters represent groupings of Boolean values, the control relays that indicate the status of the various components or alarm conditions. Still others represent actual decimal values, like the wind speed or the battery voltage.

The software that performs this decoding operation is written in PERL (Practical Extraction and Report Language), an interpreted high-level programming language commonly used in web site development. PERL was chosen for this task because of its powerful data manipulation abilities, as well as the fact that the program must be able to run in a UNIX environment, as that is where the raw data resides. This program first parses the data into columns, and then reads through it row by row, decoding each piece of information as it goes. Any gaps in the data, i.e. missing rows, are filled in with zeroes and flagged.

Although relatively simple in nature, this program is made slightly more complicated by the requirement that it be fully automated. When the coprocessor sends the data each day, it also issues the command to execute the PERL program. This program must then find the appropriate monthly file to append the data to, based on the date the information was recorded, and then save the data to that file as it is decoded. The program must also create a new monthly file and save the data there if it detects a change in month at any point during the process.

### 10.3 Data Analysis and Reporting

At the end of a given month, the data decoding process results in a lengthy text file, in spreadsheet readable format, containing an entire month of 10-minute data, decoded into its appropriate format and containing all recorded information regarding the performance of the wind-diesel system. The data is still extremely unwieldy in this form and would not be of very much use to other than the control system design engineers, and even then only to provide a detailed view of system operation at a given point in time, not to give an overview of system performance. The data must be analyzed and reduced to summary charts and tables to be more generally useful. Because this process can be accomplished most easily with a spreadsheet program, Microsoft Excel was chosen to perform this task instead of PERL. Excel also allows the data to be viewed and manipulated on PCs, giving access to a broad audience of project stakeholders. In essence, this program takes the monthly data file and reduces it to a neat, concise monthly report. It analyzes all of the data, calculating various averages, totals, and other summary values, from which it creates and formats various tables and charts, showing various performance trends and relationships.

At the end of every month, the monthly datafile must be manually imported into the Excel program for processing. Once the program is run, the resulting monthly report will be converted to Adobe Acrobat PDF files and copied to the project web site, enabling any authorized person to access and review all of the system performance data.

REPORT DOCUMENTATION PAGE			Form Approved OMB NO. 0704-0188	
Public reporting burden for this collection of information is estimated to average 1 hour per response, including the time for reviewing instructions, searching existing data sources, gathering and maintaining the data needed, and completing and reviewing the collection of information. Send comments regarding this burden estimate or any other aspect of this collection of information, including suggestions for reducing this burden, to Washington Headquarters Services, Directorate for Information Operations and Reports, 1215 Jefferson Davis Highway, Suite 1204, Arlington, VA 22202-4302, and to the Office of Management and Budget, Paperwork Reduction Project (0704-0188), Washington, DC 20503.				
1. AGENCY USE ONLY (Leave blank)	2. REPORT DATE May 2002	3. REPORT TYPE AND DATES COVERED Technical Report		
4. TITLE AND SUBTITLE Wales, Alaska, High-Penetration Wind-Diesel Hybrid Power System			5. FUNDING NUMBERS WER21750	
6. AUTHOR(S) Stephen M. Drouilhet Mari Shirazi				
7. PERFORMING ORGANIZATION NAME(S) AND ADDRESS(ES)			8. PERFORMING ORGANIZATION REPORT NUMBER	
9. SPONSORING/MONITORING AGENCY NAME(S) AND ADDRESS(ES) National Renewable Energy Laboratory 1617 Cole Blvd. Golden, CO 80401-3393			10. SPONSORING/MONITORING AGENCY REPORT NUMBER  NREL/TP-500-31755	
11. SUPPLEMENTARY NOTES				
12a. DISTRIBUTION/AVAILABILITY STATEMENT National Technical Information Service U.S. Department of Commerce 5285 Port Royal Road Springfield, VA 22161			12b. DISTRIBUTION CODE	
13. ABSTRACT ( <i>Maximum 200 words</i> ) To reduce the cost of rural power generation and the environmental impact of diesel fuel usage, the Alaska Energy Authority (AEA), Kotzebue Electric Association (KEA, a rural Alaskan utility), and the National Renewable Energy Laboratory (NREL), began a collaboration in late 1995 to implement a high-penetration wind-diesel hybrid power system in a village in northwest Alaska. The project was intended to be both a technology demonstration and a pilot for commercial replication of the system in other Alaskan villages. During the first several years of the project, NREL focused on the design and development of the electronic controls, the system control software, and the ancillary components (power converters, energy storage, electric dump loads, communications links, etc.) that would be required to integrate new wind turbines with the existing diesels in a reliable highly automated system. Meanwhile, AEA and KEA focused on project development activities, including wind resource assessment, site selection and permitting, community relationship building, and logistical planning. Ultimately, the village of Wales, Alaska, was chosen as the project site. Wales is a native Inupiat village of approximately 160 inhabitants, with an average electric load of about 75 kW.				
14. SUBJECT TERMS: wind energy; wind-diesel hybrid systems; Wales, Alaska; Alaska Energy Authority; Kotzebue Electric Association			15. NUMBER OF PAGES	
			16. PRICE CODE	
17. SECURITY CLASSIFICATION OF REPORT Unclassified	18. SECURITY CLASSIFICATION OF THIS PAGE Unclassified	19. SECURITY CLASSIFICATION OF ABSTRACT Unclassified	20. LIMITATION OF ABSTRACT  UL	