

# Wind Turbine Lightning Protection Project

1999—2001

Brian McNiff  
*McNiff Light Industry*  
*Harborside, Maine*



**NREL**

**National Renewable Energy Laboratory**

1617 Cole Boulevard  
Golden, Colorado 80401-3393

NREL is a U.S. Department of Energy Laboratory  
Operated by Midwest Research Institute • Battelle • Bechtel

Contract No. DE-AC36-99-GO10337

# Wind Turbine Lightning Protection Project

1999—2001

Brian McNiff  
*McNiff Light Industry*  
*Harborside, Maine*

NREL Technical Monitor: Eduard Muljadi

Prepared under Subcontract No.: TAM-7-17215-01



**NREL**

**National Renewable Energy Laboratory**

1617 Cole Boulevard  
Golden, Colorado 80401-3393

NREL is a U.S. Department of Energy Laboratory  
Operated by Midwest Research Institute • Battelle • Bechtel

Contract No. DE-AC36-99-GO10337

## NOTICE

This report was prepared as an account of work sponsored by an agency of the United States government. Neither the United States government nor any agency thereof, nor any of their employees, makes any warranty, express or implied, or assumes any legal liability or responsibility for the accuracy, completeness, or usefulness of any information, apparatus, product, or process disclosed, or represents that its use would not infringe privately owned rights. Reference herein to any specific commercial product, process, or service by trade name, trademark, manufacturer, or otherwise does not necessarily constitute or imply its endorsement, recommendation, or favoring by the United States government or any agency thereof. The views and opinions of authors expressed herein do not necessarily state or reflect those of the United States government or any agency thereof.

Available electronically at <http://www.osti.gov/bridge>

Available for a processing fee to U.S. Department of Energy  
and its contractors, in paper, from:

U.S. Department of Energy  
Office of Scientific and Technical Information  
P.O. Box 62  
Oak Ridge, TN 37831-0062  
phone: 865.576.8401  
fax: 865.576.5728  
email: [reports@adonis.osti.gov](mailto:reports@adonis.osti.gov)

Available for sale to the public, in paper, from:

U.S. Department of Commerce  
National Technical Information Service  
5285 Port Royal Road  
Springfield, VA 22161  
phone: 800.553.6847  
fax: 703.605.6900  
email: [orders@ntis.fedworld.gov](mailto:orders@ntis.fedworld.gov)  
online ordering: <http://www.ntis.gov/ordering.htm>



## Abstract

The National Renewable Energy Laboratory (NREL) instituted a lightning protection research and support program to help minimize lightning damage to wind turbines in the United States. The chief goal was to further the understanding of effective lightning damage mitigation techniques throughout the U.S. wind industry. To that end, three main efforts were carried out: a field test program; evaluation and documentation of protection on selected turbines; and a literature search and effective dissemination of the accumulated information. The results of these efforts are reported in this document.

The field-test program was instituted to observe lightning activity, system protection response, and damage at a wind power plant as part of the Department of Energy (DOE)/Electric Power Research Institute (EPRI) Turbine Verification Program (TVP). Lightning-activated surveillance cameras were installed along with a special storm-tracking device to observe the activity in the wind plant area. The turbines in the wind plant were instrumented with lightning current detection and ground current detection devices to log the direct and indirect strike activity at each unit. Also, a surge monitor was installed and activated on the site utility mains interface to track incoming activity from the transmission lines. Maintenance logs were used to verify damage, estimate the caused downtime, and determine repair costs. More than three years of testing actual strikes to turbines and the site were recorded on video and the detection devices. In addition, an array of modifications to the turbine and site lightning protection systems were instituted and evaluated. These modifications were demonstrated to have significantly reduced damage to the turbines from lightning activity.

The modifications were implemented at other TVP sites and used as the basis for retrofits to similar turbines throughout the United States. Initially, the existing lightning protection at TVP sites were documented. McNiff Light Industry (MLI) worked with lightning protection consultants, wind turbine manufacturers, operators, and participating TVP utilities to improve that protection. The field test was used as a proving ground for the protection methodology.

TVP participants and the wind industry in general were informed of the current state-of-the-art understanding of wind turbine lightning protection. This was done at TVP workshops, site-specific visits, and wind industry conferences. Also, MLI participated in the development of an International Electrotechnical Commission (IEC) wind turbine lightning-protection technical report, IEC 61400-24 (CDV), which is expected to be released in 2001. The IEC document is an excellent starting point for those looking for guidance on wind turbine protection, and it is recommended that any interested reader get a copy through [IEC](#).



# Table of Contents

|   |           |
|---|-----------|
| <b>1 Project Overview.....</b>  | <b>1</b>  |
| 1.1 Program Objectives.....   | 1         |
| 1.2 Field Test.....   | 2         |
| 1.3 Literature Review.....  | 2         |
| 1.4 Site Surveys.....   | 2         |
| 1.5 Lightning Protection System Improvements.....                         | 2         |
| 1.6 Dissemination of Information.....                                     | 2         |
| <b>2 Lightning Protection Project Field Test.....</b>                     | <b>3</b>  |
| 2.1 Field Test Goals.....   | 3         |
| 2.2 CSW Wind Park Description and Lightning Protection System Survey..... | 3         |
| 2.3 Field Test Plan.....  | 3         |
| 2.4 Test Approach.....  | 3         |
| 2.5 Turbine Strike Detection.....   | 4         |
| 2.5.1 Inductive Loop Voltage.....   | 5         |
| 2.5.2 Ground and Neutral Current.....                                     | 6         |
| 2.5.3 Sensor Verification and Calibration.....                            | 6         |
| 2.6 Strike Sensing.....   | 7         |
| 2.7 Video Surveillance.....   | 8         |
| 2.8 Utility Line Surges.....  | 8         |
| 2.9 Other Test Setup Issues.....  | 9         |
| 2.9.1 Time Coordination and Stamping.....                                 | 9         |
| 2.9.2 Test Equipment Protection.....                                      | 9         |
| 2.9.3 Test Period.....  | 9         |
| 2.9.4 Documentation.....  | 9         |
| <b>3 Data Analysis and Preliminary Observations.....</b>                  | <b>11</b> |
| 3.1 Results of Field Test at CSW Site.....                                | 11        |
| 3.1.1 Turbine Sensor Data.....  | 12        |
| 3.1.2 Strike Video Data.....  | 12        |
| 3.1.3 ESID and Stormscope Data.....                                       | 12        |
| 3.2 CSW Site Damage History.....  | 13        |
| 3.3 Other TVP Site Damage.....  | 13        |
| 3.4 TVP Retrofits.....  | 16        |
| 3.5 Results from IVPC.....  | 17        |
| <b>4 Literature Review.....</b>   | <b>20</b> |
| 4.1 Existing Standards.....   | 20        |

|          |  |           |
|----------|--|-----------|
| 4.1.1    | “Standard for the Installation of Lightning Protection Systems,” NFPA 780        | 20        |
| 4.1.2    | “Protection of Structures Against Lightning,” IEC 61024                          | 20        |
| 4.1.3    | “The Assessment of Risk Due to Lightning,” IEC 61662                             | 20        |
| 4.1.4    | “Protection Against Lightning Electromagnetic Impulses,” IEC 61312               | 20        |
| 4.1.5    | “Grounding of Industrial and Commercial Power Systems,” IEEE 142- 1991           | 21        |
| 4.1.6    | “Guide for Safety in AC Substation Grounding,” ANSI/IEEE 80 – 2000               | 21        |
| 4.2      | Wind Turbine Specific Literature   | 21        |
| 4.2.1    | “How to Protect a Wind Turbine from Lightning”                                   | 21        |
| 4.2.2    | “Lightning Protection of Wind Turbine Generator Systems...”                      | 21        |
| 4.2.3    | “Lightning Protection for Composite Rotor Blades”                                | 22        |
| 4.3      | Recent Wind Turbine Specific Literature  | 22        |
| 4.3.1    | “Wind Turbine Generator Systems, Part 24: Lightning Protection,”<br>IEC 61400-24 | 22        |
| 4.3.2    | “Lightning Protection of Wind Turbines—A Designers Guide to Best Practices”      | 22        |
| 4.3.3    | DEFU, Recommendation No. 25, “Lightning Protection of Wind Turbines”             | 22        |
| 4.4      | More In Depth Literature   | 22        |
| 4.4.1    | Fisher and Plumer, “Lightning Protection of Aircraft”                            | 22        |
| 4.4.2    | Uman, “The Lightning Discharge”  | 23        |
| 4.4.3    | Golde, “Lightning, Volume 1- the Physics of Lightning”                           | 23        |
| 4.5      | Lightning Protection Course  | 23        |
| 4.5.1    | Summary  | 23        |
| 4.5.2    | Lightning Technologies, Inc.   | 23        |
| <b>5</b> | <b>TVP Site Surveys and Lightning Risk</b>                                       | <b>24</b> |
| 5.1      | Lightning Activity at TVP Sites  | 24        |
| 5.2      | Lightning Risk at TVP Wind Sites   | 25        |
| 5.3      | Survey of Lightning Protection at GMP Site                                       | 26        |
| 5.3.1    | Turbines and Site  | 26        |
| 5.3.2    | Blade Protection   | 26        |
| 5.3.3    | Ground Paths and Equipotential Bonding   | 27        |
| 5.3.4    | Shielding  | 29        |
| 5.3.5    | VPC Protection (uptower control box)   | 29        |
| 5.3.6    | Base Controller Protection   | 29        |
| 5.3.7    | SCADA  | 30        |
| 5.4      | Survey of Lightning Protection at the CSW Site                                   | 31        |
| 5.4.1    | Turbines and Site  | 31        |
| 5.4.2    | Blade Protection   | 31        |
| 5.4.3    | Grounding  | 31        |
| 5.4.4    | Other Differences to GMP Turbines  | 32        |
| 5.5      | LG&E/ Kennetech Site in West Texas   | 33        |
| 5.5.1    | Turbines and Site  | 33        |
| 5.5.2    | Blades and Nacelle   | 33        |
| 5.5.3    | Grounding and Bonding  | 34        |
| 5.5.4    | Shielding  | 35        |
| 5.5.5    | Communication System   | 35        |
| 5.6      | Algona, Iowa Site  | 36        |

|          |   |           |
|----------|---|-----------|
| 5.6.1    | Blades and Nacelle.....   | 36        |
| 5.6.2    | Grounding and Bonding.....                                      | 37        |
| 5.6.3    | Shielding.....  | 38        |
| 5.6.4    | Communication System.....                                       | 38        |
| 5.7      | NPPD Site.....  | 39        |
| 5.7.1    | Grounding System.....   | 39        |
| 5.8      | IVPC Site Survey.....   | 40        |
| 5.8.1    | Turbines and Site.....  | 40        |
| 5.8.2    | Blade Protection.....   | 40        |
| 5.8.3    | Grounding and Bonding Considerations.....                       | 41        |
| 5.8.4    | Surge Protection.....   | 42        |
| 5.8.5    | Operator Safety Considerations.....                             | 42        |
| 5.8.6    | Shielding Considerations.....                                   | 43        |
| 5.9      | York Research Site.....   | 43        |
| <b>6</b> | <b>Lightning Protection Retrofits.....</b>                      | <b>44</b> |
| 6.1      | Recommended Modifications to Zond Z40.....                      | 44        |
| 6.1.1    | Initial Zond Z40 Lightning Protection Modifications.....        | 44        |
| 6.1.1.1  | Tower Top Modifications.....                                    | 45        |
| 6.1.1.2  | Base Controller Modifications.....                              | 45        |
| 6.1.1.3  | SCADA Protection.....   | 45        |
| 6.1.1.4  | Materials.....  | 45        |
| 6.1.2    | Increased Lightning Protection for Zond Z40.....                | 46        |
| 6.1.2.1  | Tower Top.....  | 46        |
| 6.1.2.2  | Base Controller Shielding and Surge Protection.....             | 47        |
| 6.1.2.3  | SCADA System.....   | 47        |
| 6.1.2.4  | Materials.....  | 47        |
| 6.2      | Retrofit Recommended to Z-550 and Z-750 Owners.....             | 47        |
| 6.2.1    | MLI Protection Improvement Recommendations for the Z50.....     | 47        |
| 6.2.1.1  | Tower Top Items.....  | 47        |
| 6.2.1.2  | Base Controller Items.....                                      | 48        |
| 6.2.2    | Lightning Technologies Improvement Recommendations for Z50..... | 48        |
| 6.2.2.1  | Blade protection.....   | 48        |
| 6.2.2.2  | Surge Suppressors.....  | 48        |
| 6.2.2.3  | Bonding and Shielding.....                                      | 48        |
| <b>7</b> | <b>Protection Recommendations.....</b>                          | <b>50</b> |
| 7.1      | Turbine Buyer Considerations.....                               | 50        |
| 7.2      | Site Design Considerations.....                                 | 50        |
| 7.2.1    | General Site Issues.....  | 50        |
| 7.2.2    | Grounding.....  | 50        |
| 7.2.3    | High-Voltage Distribution System.....                           | 51        |
| 7.3      | Turbine Design Considerations.....                              | 51        |
| 7.3.1    | Rotor.....  | 51        |
| 7.3.2    | Shielding.....  | 51        |
| 7.3.3    | Surge Protection.....   | 51        |
| 7.3.4    | Bearings and Gears.....   | 51        |



|          |   |                                       |
|----------|---|---------------------------------------|
| 7.4      | Turbine Installation Considerations .....   | 51                                    |
| 7.5      | Personnel Safety Considerations.....  | 51                                    |
| <b>8</b> | <b>Bibliography .....</b>   | <b>53</b>                             |
|          | <b>Appendix A: Wind Turbine Lightning Protection Project: Field Test Plan .....</b> | <b>A-1</b>                            |
|          | <b>Appendix B: Plan for Test of Strike Sensor in a High-Voltage Laboratory.....</b> | <b>B-1</b>                            |
|          | <b>Appendix C: Minutes for WTG Protection Planning Meeting.....</b>                 | <b>C-Error! Bookmark not defined.</b> |
|          | <b>Appendix D: Field Test Documentation.....</b>                                    | <b>D-1</b>                            |
|          | <b>Appendix E: IVPC Statistics.....</b>   | <b>E-1</b>                            |

## List of Figures

|            |  |      |
|------------|--|------|
| Figure 1   | CSW Site Layout.....   | 4    |
| Figure 2   | Field Test Sensors.....  | 5    |
| Figure 3   | Damaged Zond Z40FS Blade at GMP Site .....                         | 15   |
| Figure 4   | GMP/Searsburg Z40FS Blade Strike Damage .....                      | 16   |
| Figure 5   | Zond Blade Conductor Retrofit .....                                | 17   |
| Figure 6   | Strike Sensors at IVPC .....                                       | 18   |
| Figure 7   | IVPC/Vestas Blade Damage.....                                      | 19   |
| Figure 8.  | Mean annual thunderstorm days in the United States .....           | 24   |
| Figure 9   | NLDN lightning flash density report for Big Springs, Texas.....    | 25   |
| Figure 10  | GMP - Zond Z40 FS - Grounding Scheme.....                          | 27   |
| Figure 11  | GMP/Zond Z-40FS Grounding and Bonding.....                         | 28   |
| Figure 12  | GMP Site Layout.....   | 30   |
| Figure 13  | CSW Turbine Grounding Plan View.....                               | 32   |
| Figure 14  | CSW Turbine Grounding - Elevation.....                             | 33   |
| Figure 15  | KVS-33 Grounding Scheme.....                                       | 34   |
| Figure 16  | KVS-33 Site Communication System with Surge Protection Detail..... | 35   |
| Figure 17  | Algona Z-50 Grounding Details.....                                 | 36   |
| Figure 18  | Algona Z-50 Grounding and Bonding Profile.....                     | 37   |
| Figure 19  | NPPD Site Layout .....   | 38   |
| Figure 20  | NPPD Z-50 Grounding Scheme .....                                   | 39   |
| Figure 21  | IVPC Vestas V44 Blade Protection.....                              | 40   |
| Figure 22  | Vestas V44 Blade Protection Receptor/Terminal.....                 | 41   |
| Figure 23  | IVPC Vestas V44 Grounding .....                                    | 41   |
| Figure 24  | IVPC/Vestas V44 Nacelle Protection.....                            | 42   |
| Figure 25  | Big Springs/York Research Grounding Detail .....                   | 44   |
| Figure A-1 | Test Sensor Locations .....  | A-5  |
| Figure A-2 | Instrumentation Description for CSW Field Test.....                | A-11 |
| Figure D-1 | LPP Instrumentation Schematic .....                                | D-5  |
| Figure D-2 | LPP Camera Control .....   | D-6  |
| Figure D-3 | LPP Camera Circuit .....   | D-7  |

## List of Tables

|           |  |     |
|-----------|--|-----|
| Table 1   | Sensor Calibrations .....                                    | 6   |
| Table 2   | Sample of ESID Data.....                                     | 7   |
| Table 3   | CSW Strike Data.....   | 11  |
| Table 4   | Fort Davis Lightning Damage .....                            | 13  |
| Table 5   | Lightning-Related Faults and Downtime by Site for 1999 ..... | 13  |
| Table 6   | Lightning Damage Detail.....                                 | 14  |
| Table 7   | IVPC Blade Damage and Repair Statistics.....                 | 19  |
| Table 8   | TVP Lightning Strike Risk .....                              | 26  |
| Table 9   | Initial improvements for Z40 Materials List.....             | 46  |
| Table 10  | Increased Protection for Z40 Materials List .....            | 47  |
| Table D-1 | Keypad Programming of Campbell Datalogger .....              | D-3 |
| Table E-1 | IVPC Turbine Lightning Damage.....                           | E-1 |



# 1 Project Overview

In the early development of modern wind turbine generators (WTG) in the United States, wind turbines were primarily located in California where lightning activity is the lowest in this country. As such, lightning protection for wind turbines was not considered to be a major issue for designers or wind farm operators during the 1980s. However, wind turbine installations have recently increased in the Midwest, Southwest and other regions of the United States where lightning activity is significantly more intense and lightning damage to wind turbines is more common. There is a growing need, therefore, to better understand lightning activity on wind farms and its impact on wind turbine operation. In response to this, the Lightning Protection Project was conceived by the National Renewable Energy Laboratory (NREL) to improve the understanding of lightning caused damage to wind turbines and how to protect them.

The first project under the U.S. Department of Energy (DOE)/Electric Power Research Institute (EPRI) Turbine Verification Program (TVP) was installed and commissioned near Fort Davis, Texas, in early 1996. These 12 first-generation Zond 40-m (131-ft), 550-kW turbines were integrated into a remote part of the Central and South West Services (CSW) utility grid. A very high incidence of damage suspected to be a result of lightning occurred during the first summer of operation. Although this is an area with a high frequency of lightning activity, it was not clear what the causal mechanisms were for much of the suspected lightning damage. Because many of the candidate TVP projects were in moderate to high lightning-risk areas, NREL elected to investigate solutions to lightning damage problems – both specific to this site and in general – before they became epidemic.

McNiff Light Industry (MLI) was selected by NREL under Subcontract TAM-7-17215-01 to carry out this investigation. This is the final report of the Lightning Protection Project.

## 1.1 Program Objectives

In early 1997, a meeting was convened by NREL to bring together TVP utilities, turbine manufacturers, wind turbine and lightning protection consultants, and several groups with experience in operating wind turbines in the high lightning-risk areas of Texas. Some very good information was shared at this meeting, and participants recommended that DOE investigate lightning protection as it pertains to wind turbine installations. The meeting minutes are included as appendix C.

As a result of this meeting, a lightning-protection research and support program, the Lightning Protection Project, was instituted by NREL. The chief goal was to help minimize lightning damage to wind turbines in the TVP and, by extension, the U.S. wind industry in general. To that end, the following three main efforts were carried out:

- A field-test program to identify damage mechanisms and verify protection methods
- An evaluation and documentation of protection on TVP turbines
- A literature search and effective dissemination of the accumulated information.

As an added benefit, MLI participated in the development of the International Electrotechnical Commission Technical Report 61400-24 on the protection of wind turbines from lightning damage. This document was a joint effort of over a dozen researchers from eight countries, and it provided a much more thorough document than MLI could have provided alone.

## **1.2 Field Test**

MLI decided to implement the field test part of the project as soon as possible in order to increase the odds of capturing good lightning activity data in the period allotted. Planning this involved designing sensors and determining the approach required to meet the objective of detailing the damage mechanism on a field of wind turbines. This is reported on in Sections 2 and 3.

## **1.3 Literature Review**

A thorough search and review of literature applicable to lightning protection of wind turbines was carried out. A review of the most useful literature is presented in Section 4 as a guide for interested readers to locate information applicable to their needs.

## **1.4 Site Surveys**

Evaluating the effectiveness of lightning protection systems is difficult, but the first step includes documenting the existing protection. Documenting the protection is specific to both the turbines being used and the site details. We decided to do these site surveys for as many sites as possible in the TVP program. These are presented in Section 5 along with a description of the lightning activity and risk at each site.

## **1.5 Lightning Protection System Improvements**

The CSW, Green Mountain Power (GMP), Algona, and Nebraska Public Power District (NPPD) sites employed 550 kW or 750 kW turbines from Zond. MLI and Lightning Technologies both recommended improvements to the lightning protection systems originally in place on the turbines. These recommendations are presented in Section 6.

## **1.6 Dissemination of Information**

The information dissemination was through the following methods:

- Papers and presentations at Windpower 97 <sup>1</sup>, Windpower 98 <sup>2</sup>, AIAA 98 <sup>3</sup>, Windpower 99 <sup>4</sup>, EWECE 1999 <sup>5</sup>, and Windpower 2000 <sup>6</sup> conferences
- TVP meetings in 1997, 1998, and 1999
- Participation in the International Electrotechnical Commission (IEC) 61400-24 <sup>7</sup> technical report on WTG lightning protection
- Publication in this final report.

In addition to the turbine specific recommendations presented in Section 6, we have included general recommendations in Section 7.

Although we provided a Web page and maintained it for a couple of years, this avenue is no longer tenable after the termination of this project. We feel, however, that the IEC 61400-24 technical report, the references reviewed, and this document provide sufficient information to those interested in wind turbine lightning protection.

## 2 Lightning Protection Project Field Test

As part of the Lightning Protection Project instituted by NREL, a WTG lightning field test program was devised and implemented in July 1997 at the CSW wind park near Fort Davis, Texas. This was carried out in order to observe lightning activity, system lightning protection response, and lightning strike damage on a wind power plant in a high lightning-risk area.

### 2.1 Field Test Goals

The test goals were as follows:

- Survey and document the CSW site grounding and lightning protection system
- Document lightning activity at the CSW Wind Park on each turbine and in the wind park
- Correlate data acquisition with site operations and maintenance (O&M) records
- Correlate measured site data to lightning location information data from the National Lightning Detection Network (NLDN)
- Evaluate modifications to increase the immunity of the turbines against lightning damage
- Inform TVP stakeholders and the wind industry in general of progress and results.

### 2.2 CSW Wind Park Description and Lightning Protection System Survey

The CSW Wind Park near Fort Davis, Texas, (see site layout in Figure 1) consists of 12 [Zond Z-40A](#), 550 kW wind turbines installed along two ridges running approximately north–south. These stall-controlled turbines have three-blade, 40 m (131 ft) rotors with aileron control surfaces to assist in stopping the rotor. They operate at near fixed speed using induction generators. All of the turbines are mounted atop 40 m (131 ft) steel truss towers. Two meteorological towers are installed among the turbines. A one-story steel operations building is located on a saddle between the two ridges.

The grounding and lightning protection system was documented by physical inspection, and it is presented in Sections 5.3 and 5.4. It appears that the utility line and the communication system are the major catchments for damage due to indirect effects (e.g., surges induced by nearby lightning elevating local potential).

### 2.3 Field Test Plan

As mentioned, a test was devised to observe lightning activity in a typical wind farm and evaluate the system response of each WTG and the whole plant. The following sections describe the test. A complete copy of the test plan is included in appendix A.

### 2.4 Test Approach

The site lightning activity was documented by:

- Detecting lightning current passage through each turbine and into the grounding system
- Strike sensing and logging within 30 miles
- Video surveillance of strikes on turbines and within the wind park
- Monitoring of surges incoming to the park from the utility mains feeder.

It was not our intent to measure exact lightning currents on the turbines, but we did want to log lightning activity with an accurate time stamp to allow correlation of data to the national Lightning Detection Network (NLDN) database. From the database we expected to determine stroke peak current and other parameters to correlate to the damage at the turbines.

The installed equipment used to achieve the test goals are described in the following sections.

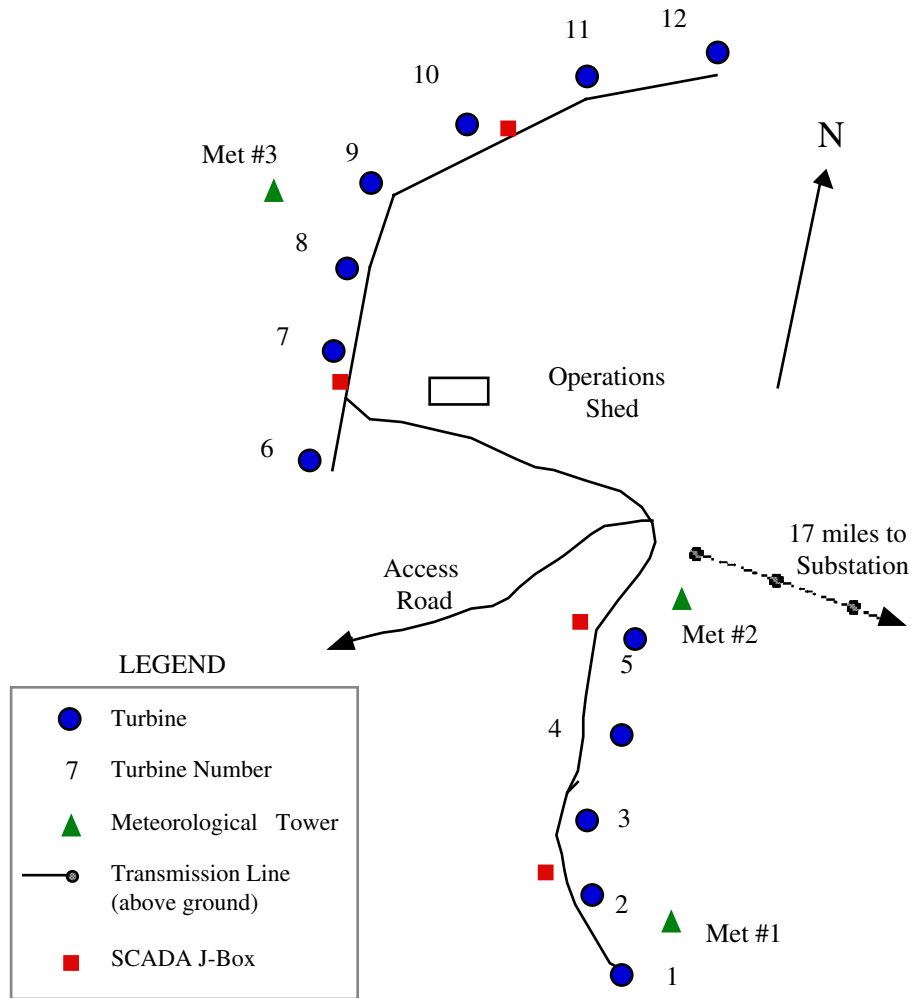

**Figure 1. CSW site layout**

## 2.5 Turbine Strike Detection

Three sensors were used to detect and track the flow of direct strike lightning current at each turbine. Attached to each sensor was signal conversion circuitry housed in a cast aluminum box. Data were conducted by optical pulses through fiber to a data acquisition system (DAS) on each turbine. Opto-electronic translation circuitry and a Campbell Scientific CR500 datalogger operated autonomously in a steel box mounted to base webbing on each tower (see Figure 2). The datalogger was powered by a 12 VDC, 7 A-hr battery and the sensors were powered by 9 VDC batteries.

Two different types of sensors were employed. Both were tested in the Lightning Technologies high-voltage laboratory in Pittsfield, Massachusetts, to verify performance in detecting lightning current.

Data were collected once every two weeks by the site operators using a laptop to directly download each turbine DAS. It took about one hour to download data from all turbines in this manner.

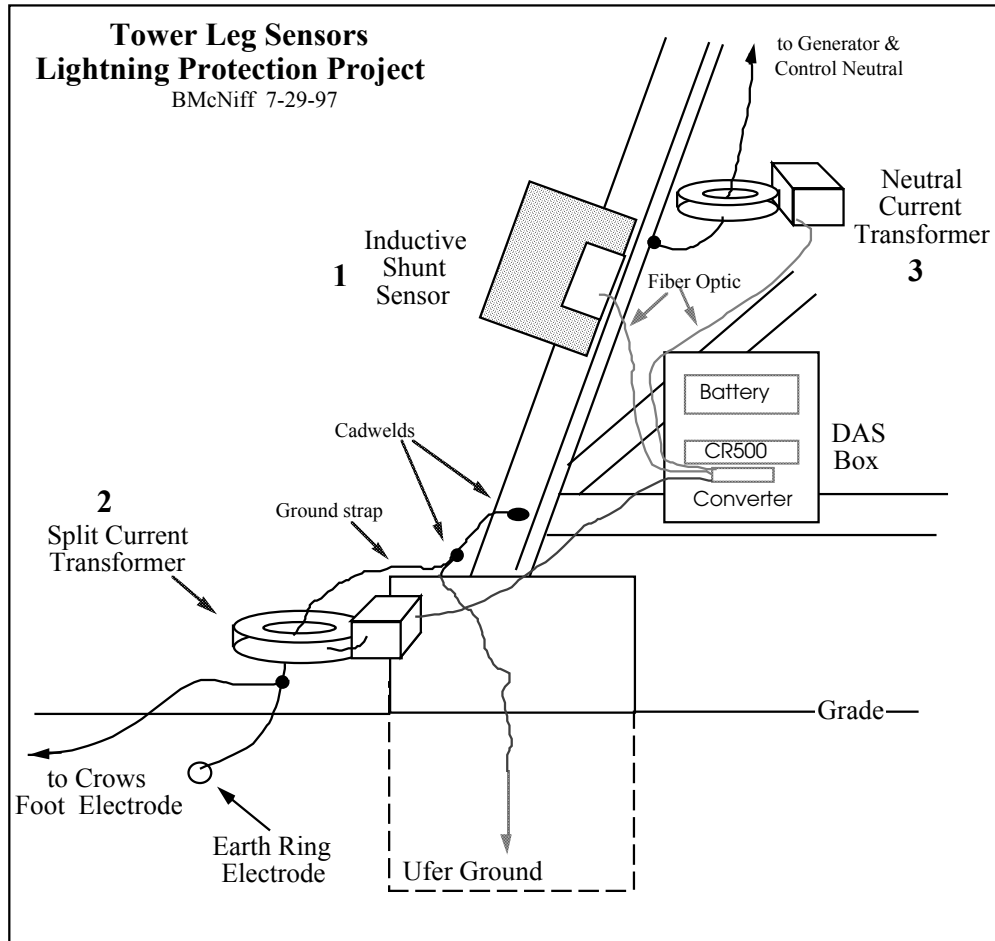

**Figure 2. Field test sensors**

### 2.5.1 Inductive Loop Voltage

The first sensor (indicated as Sensor 1 in Figure 2) was based on measuring the magnetic flux ( $\phi$ ) change caused by the extremely high current rate of rise at the onset of a lightning strike. We sensed this by measuring the induced voltage ( $V_{loop}$ ) created by the flux change ( $d\phi/dt$ ) in a 12.7 cm (5 in.) wide by 25.4 cm (10 in.) tall, 3 turn coil clamped to the edge of a tower leg as shown in Figure 2. The wire loop acted as a transformer, picking up the potential difference along a 25.4 cm (10 in.) section of the tower leg. At the time scale of a lightning strike (several microsecond to peak current), the tower leg voltage is governed by the inductance of the conduction path. Therefore, the induced voltage is proportional to the rate of change of the lightning current ( $dl/dt$ ):

$$V_{loop} \propto N \frac{d\phi}{dt} \propto \frac{dl}{dt}$$

This voltage pulse was integrated by the sensor electronics, and the approximate magnitude of the integral was passed to the data logger as a variable duration light pulse through an optical fiber. Our measurement



was roughly proportional to peak current ( $I_{peak}$ ) because we integrated the absolute value of the loop voltage,  $V(t)$ . The rapid current rate of rise starts at a zero value before the event and essentially terminates (the negative rate of rise is several orders of magnitude lower) at the peak current:

$$I_{peak} \propto \int |V(t)| dt \propto \int_{rise} \frac{dI}{dt} dt$$

The circuitry was quite simple and robust, using discrete components with limited linear region and bandwidth. However, our intent was to determine the order of magnitude of the strike current, not the exact waveform characteristics.

### 2.5.2 Ground and Neutral Current

The second sensor (indicated as Sensors 2 and 3 in Figure 2) measured the lightning current directly using transformers to step the current down to easily measured levels. The sensor circuit integrated the absolute value of the measured current and again issued a light pulse of proportional duration. As the integral of current ( $i$ ) is charge ( $Q$ ):

$$Q_{charge} = \int i(t) dt$$

This sensor was a rough indicator of how much charge passed through the aperture of the current transformer (CT) during the strike. Here again our accuracy was quite limited, not only by the parasitics in the circuit, but also by leakage inductance and possible magnetic saturation of the current transformers (primary transformer and PC board mounted CT).

On each turbine there were two current sensors: one split torroidal CT was installed around a tower ground strap, and the other was around the generator case path to ground (see Figure 2). The current path sensed by the latter (our so-called “neutral current sensor”) is actually the path from the controller box and the generator junction box (attached mechanically to generator housing) to the ground electrode. It should be noted that this is not really a neutral in the sense of carrying the return current to the utility.

The tower grounds are rather complex (described in Section 5), but the split CT measures the current into the ring electrode and a crow's foot from one tower leg. It does not include any current in the Ufer ground, which is generally accepted to be a good ground (see NFPA 780<sup>9</sup>). The regular CT measures the current in the neutral to ground path (from the generator case or controller).

### 2.5.3 Sensor Verification and Calibration

Both types of sensors (and the whole DAS) were tested for accuracy and robustness in the Lightning Technologies high-voltage laboratory in early June of 1997. A complete test plan for this effort is included in Appendix B.

The calibrations for the sensors were also determined there, and they are listed in Table 1 below. Please note that these are inexact by their nature. Our intent was to discern actual strikes from indirect effects, stray motor currents, and ambient noise. We feel quite confident that we achieved that with the voltage loop.

**Table 1. Sensor Calibrations**

| Sensor          | Min              | Cts | Max              | Cts | Notes                           |
|-----------------|------------------|-----|------------------|-----|---------------------------------|
| Voltage Loop    | 600 A            | 1   | 5000 A           | 120 | 1 $\mu$ s rise, 10 $\mu$ s fall |
| Ground Current  | 300 A@ 7 $\mu$ s | 1   | 10 kA@ 7 $\mu$ s | 150 | Avg peak is higher              |
| Neutral Current | 300 A@ 7 $\mu$ s | 1   | -                | -   | NA                              |

Note that the voltage loop and the ground current sensors could respond to a range of signals. The neutral current sensor, alternatively, merely detected the passage of something exceeding the threshold current. It should be stated that we assumed that our monitoring locations conducted only 15% (ground current) to 25% (voltage loop) of the direct lightning strike current. This was based on simple circuit assumptions of the tower and grounds (e.g., four tower legs share equally in the total strike current).

Although lightning strike currents vary significantly, they do have a statistically observed range (see NFPA 780). We sized our electronics to respond to a minimum strike of 5 kA with a rate of rise of 2 kA/μs. More than 97% of all lightning strikes exceed this level. Above 20 kA, a maximum value of 120 counts will be indicated. We did this because we were range limited, and we were most interested in an accurate threshold.

## 2.6 Strike Sensing

An Electrical Storm Identification Device (ESID) from [Global Atmospheric](#) was installed on the roof of the operations building. This device provided tracking of incoming and developing lightning storms within 48 km (30 mi). The roof top mounted sensor communicated to a receiving unit in the operations building via fiber optic. The receiving unit was configured to switch relays to activate the video equipment.

We programmed the ESID to provide a time-stamped log (to the PC) of lightning event counts in 4 different ranges: overhead [0 to 8 km (5 mi)], nearby [8 to 16 km (5 to 10 mi)], distant [16 to 48 km (10 to 30 mi)], and cloud to cloud [up to 80 km (50 mi) distant]. The data stream from the ESID to the computer (every 60 seconds) is switched on only when lightning is detected, and it gives the number of strikes in the last 5 minutes in each range (persistence) and the scan date and time. We configured the ESID to turn on power to the video cameras when any lightning was detected within any 5-minute period. However, video recording and the scanning were activated when nearby and overhead strikes were sensed. A sample of the parsed serial ASCII stream to the PC is shown in Table 2. You can see that a storm is moving along 16 to 48 km (10 to 30 mi) from the site because the persistence is high at lines 3, 7, and 12 corresponding to that range.

**Table 2. Sample of ESID Data**

|    | Date      | Time |     |        | Range           | Note | Persistence | Communications |
|----|-----------|------|-----|--------|-----------------|------|-------------|----------------|
|    |           | hr   | min | sec    |                 |      |             |                |
| 1  | 20-Jul-97 | 18   | 20  | 43.560 | CG LTG 0- 5 Mi  |      | 0/ 5        | COMM UP        |
| 2  | 20-Jul-97 | 18   | 20  | 43.600 | CG LTG 5-10 Mi  |      | 0/ 5        | ESID PASS      |
| 3  | 20-Jul-97 | 18   | 20  | 43.650 | CG LTG 10-30 Mi | OCNL | 10/ 5       |                |
| 4  | 20-Jul-97 | 18   | 20  | 43.690 | CLOUD DISCHARGE | OCNL | 1/ 5        |                |
| 5  | 20-Jul-97 | 18   | 21  | 43.530 | CG LTG 0- 5 Mi  |      | 0/ 5        | COMM UP        |
| 6  | 20-Jul-97 | 18   | 21  | 43.580 | CG LTG 5-10 Mi  |      | 0/ 5        | ESID PASS      |
| 7  | 20-Jul-97 | 18   | 21  | 43.620 | CG LTG 10-30 Mi | MOD  | 13/ 5       |                |
| 8  | 20-Jul-97 | 18   | 21  | 43.660 | CLOUD DISCHARGE | OCNL | 1/ 5        |                |
| 9  | 20-Jul-97 | 18   | 22  | 43.500 | CG LTG 0- 5 Mi  |      | 0/ 5        | COMM UP        |
| 10 | 20-Jul-97 | 18   | 22  | 43.540 | CG LTG 5-10 Mi  |      | 0/ 5        | ESID PASS      |
| 11 | 20-Jul-97 | 18   | 22  | 43.590 | CG LTG 10-30 Mi | MOD  | 11/ 5       |                |
| 12 | 20-Jul-97 | 18   | 22  | 43.630 | CLOUD DISCHARGE |      | 0/ 5        |                |

Note: CG LTG = cloud to ground lightning, OCNL = occasional, MOD = moderate

A PC mounted hardware/software system called Storm Tracker (from [Boltek](#)) was also provided for CSW site personnel to use to track electrical storms up to 483 km (300 mi) away. This device uses an antenna

to directionally locate strikes and plot them on a radar-type polar (ring) screen with a digital map of the local area superimposed. Data can be recorded and replayed at a later time. This unit turned out to be very useful to the site operators to determine when lightning activity came through the area

## **2.7 Video Surveillance**

Three cameras were mounted atop the operations building to record a view of the turbines during electrical storms. As noted above, the ESID was used to activate these during a storm. Three 12.7 mm (0.5 in.) charge-coupled device (CCD) cameras equipped with 8 to 48 mm (0.3 to 1.9 in.) zoom lenses were mounted in shielded, aspirated enclosures, and the video was recorded using 5-head commercial surveillance VCRs that provide accurate time-stamping and alarm-activated recording.

Camera 1 was used to view units 1 through 5 with the 8X zoom lens mounted on a fixed 25.4-cm (10-in.) stanchion. Zoom, tilt angle, and yaw orientation were manually adjusted. Camera 2 was originally mounted on an automatic scanner (yaw direction) to repeatedly pan units 6 through 12. Zoom, tilt angle, and yaw limits were manually set. A full scan cycle of the turbines took about 15 seconds. Unfortunately, the dwell time on turbines 6, 7, and 8 were not high, and we suspect that we missed a strike the first year on unit 11. As a result, we added a third camera the second year. For the remainder of the test, camera 2 viewed units 6, 7, and 8, and camera 3 viewed units 9 through 12.

The video system inside the operations building was wired to allow automatic or manual operation of cameras and scanner. As noted above, the VCRs were commanded on by the ESID and a relay control distribution box (wall-mounted). The three VCRs could be used to review tapes via an A/B switch onto a single monitor. The same method could also be used to view live feed. We modified wiring in the camera and scanner control to ensure that when the automated system commanded the video system to come on, it would, no matter what state the operators left it in. To assist operator service, we included warning lamps for tape-end alerts and manual overrides.

## **2.8 Utility Line Surges**

A power quality monitor (BMI 8010 PQNode) was mounted on the utility side of the site 25 kV distribution line. We mounted it in a meter box on the last pole on the site. It was used for two different functions. The primary function was to sample and save current and voltage waveform data when a transient pulse was detected on the 25 kV line. This information was used to correlate on site damage to incoming transients. The other role for this unit was to monitor power quality parameters such as reactive power, total harmonic distortion, and real power for the whole site output. Our original intention was to reconfigure the monitor periodically to collect long-term (instead of transient triggered) data to evaluate site power quality.

During the planning stages of this test, it was determined that the CTs were incorrectly sized for the BMI device. It appears that they were properly sized for the standard Schlumberger line meter that is installed on the same pole. This meter is polled periodically by the West Texas Utilities central monitoring system, and its scalars would have been incorrect if we changed the 25 kV CTs. Instead we stepped the current down further from the existing CTs to give a final ratio of 120:1 at the line monitor input. Unfortunately there is a loss in accuracy due to this step (3% range estimated by the CT manufacturer). This was deemed sufficiently accurate for the surge analysis needs.

The DAS computer was configured to communicate with the PQNode modem to periodically download data and reconfigure it for the two different test modes. However, this testing was not successful the first year because of problems we had with the BMI unit.

In year two, we installed a Reliable Power Meters (RPM) replacement for the BMI called a Power Recorder. This device was very simple to hook up, and it was milked by CSW operator's laptop computer monthly. The data recovery was good, but the correlation of the surge data to faults was not as easily discernible as we had hoped.

## **2.9 Other Test Setup Issues**

### **2.9.1 Time Coordination and Stamping**

The 12 dataloggers, 2 video recorders, and DAS computer had to be synchronized to maintain a consistent time stamp. This synchronization was to be used to correlate events with strike documentation from the NLDN database and the Zond/CSW site monitoring system. The prime reference was a time reference card installed in the DAS computer and periodically linked to an atomic clock. Monthly accuracy was estimated to be within 0.5 seconds.

The Campbell Scientific loggers were tested for their clock accuracy and verified to lose about 5 seconds per month. Synchronization was performed by adjusting the laptop clock to the reference computer clock before downloading the dataloggers. During the downloads the logger clocks were adjusted according to the laptop, and the difference was logged to be used in final data adjustment.

The video recorders had clocks that time stamped the VHS tapes with a claimed accuracy of +/- 1 second per month. This clock was manually updated weekly.

Finally, the DAS computer clock was used to directly time stamp the ESID data stream as it came into the computer. The power quality monitor (BMI PQNode or the RPM meter) clock was updated at the time of download by the DAS computer or by the laptop.

### **2.9.2 Test Equipment Protection**

The test equipment was protected against damage by direct strikes and indirect effects from lightning. The DAS boxes were fully autonomous with only fiber optic going into them. The cameras and ESID were grounded to the operations building steel sheathing, and all wires to and from them were either fiber optic or housed in flex conduit bonded to the devices and the building at both ends. The building is grounded in two locations to a buried earth electrode loop surrounding the building. The video coax and phone lines were protected with surge clamping devices connected to the building ground. The latter were commercial devices modified to assure a direct path to building ground. Additionally, the ESID receiver, the video system, and the PC received backup power and surge protection through an uninterruptible power supply (UPS).

### **2.9.3 Test Period**

The test lasted for three lightning seasons (July 1997 to October 1999). The dominant lightning season in the West Texas area is between mid-June and mid-September. It is interesting to note that the wind season is between December and April, well away from the lightning season. This mismatch is fortuitous in that downtime due to lightning at this site does not contribute greatly to lost turbine revenue.

### **2.9.4 Documentation**

The system components, assembly, and operation have been thoroughly documented for clarity of operation and ease of maintenance and troubleshooting. The following items were provided to the site personnel and installed in the test logbook:

- Overall test instrumentation scheme
- Camera layout schematic
- Video system wiring
- Tower grounding - plan view
- Turbine grounding - profile

Additionally, procedures and guidelines were developed and provided to the site personnel to keep the data collection and observations consistent and regular. Among these, the following were included:

- Test documentation and maintenance
- Data retrieval guidelines
- CR500 Datalogger program

All of the above listed items are included in Appendix D.

### 3 Data Analysis and Preliminary Observations

The Lightning Protection Project was successful in identifying damage mechanisms due to direct and indirect lightning effects on wind turbines. The field test produced an interesting array of data on turbine response to lightning activity. Four direct strikes were captured on videotape, and many hundreds of surge events were logged on the monitoring systems. The lightning protection retrofit instituted part way through the test was demonstrated to be effective in eliminating damage and associated downtime due to direct and nearby lightning strikes. The results of the project are reported on in this section.

#### 3.1 Results of Field Test at CSW Site

We normally heard from the site operators when a turbine took a significant amount of damage. They would first note the event from supervisory control and data acquisition (SCADA) activity (or loss of SCADA). They would then review the ESID log by replaying the recorded data at an accelerated time rate on the scope screen. If they could isolate a time of very close activity or a direct turbine strike, they would then view the video data. Normally, they would download the strike data from the dataloggers after a strike event or once every two weeks. This data and the ESID data would be emailed to us, and the videotapes would be sent to MLI.

**Table 3. CSW Strike Data**

| Item     | Date           | Julian Day | Time (hr min) | Time (sec) | Unit No.  | Lightning Voltage (cts) | Ground Current (cts) | Neutral Current (cts) |
|----------|----------------|------------|---------------|------------|-----------|-------------------------|----------------------|-----------------------|
| <b>1</b> | <b>27 July</b> | <b>208</b> | <b>1631</b>   | <b>30</b>  | <b>11</b> | <b>108</b>              | <b>156</b>           | <b>1</b>              |
|          | 27 July        | 208        | 1631          | 30         | 7         | 0                       | 148                  | 1                     |
|          | 27 July        | 208        | 1631          | 30         | 8         | 0                       | 163                  | 1                     |
|          | 27 July        | 208        | 1631          | 30         | 10        | 0                       | 156                  | 1                     |
|          | 27 July        | 208        | 1631          | 15         | 9         | 0                       | 159                  | 1                     |
|          | 27 July        | 208        | 1631          | 15         | 12        | 0                       | 159                  | 1                     |
| <b>2</b> | <b>27 July</b> | <b>208</b> | <b>1632</b>   | <b>0</b>   | <b>1</b>  | <b>210</b>              | <b>223</b>           | <b>1</b>              |
|          | 27 July        | 208        | 1632          | 15         | 2         | 9                       | 227                  | 1                     |
|          | 27 July        | 208        | 1632          | 0          | 7         | 0                       | 142                  | 1                     |
|          | 27 July        | 208        | 1632          | 0          | 8         | 0                       | 0                    | 1                     |
|          | 27 July        | 208        | 1632          | 0          | 9         | 0                       | 5                    | 1                     |
|          | 27 July        | 208        | 1632          | 0          | 10        | 0                       | 80                   | 1                     |
|          | 27 July        | 208        | 1632          | 0          | 11        | 0                       | 163                  | 1                     |
|          | 27 July        | 208        | 1632          | 0          | 12        | 0                       | 123                  | 1                     |
| <b>3</b> | <b>18 Aug</b>  | <b>230</b> | <b>2008</b>   | <b>30</b>  | <b>5</b>  | <b>8</b>                | <b>132</b>           | <b>2</b>              |
|          | 18 Aug         | 230        | 2008          | 30         | 6         | 0                       | 0                    | 1                     |
|          | 18 Aug         | 230        | 2008          | 30         | 8         | 0                       | 0                    | 1                     |
|          | 18 Aug         | 230        | 2008          | 30         | 7         | 0                       | 0                    | 1                     |
|          | 18 Aug         | 230        | 2008          | 30         | 10        | 0                       | 0                    | 1                     |
|          | 18 Aug         | 230        | 2008          | 30         | 11        | 0                       | 0                    | 1                     |
|          | 18 Aug         | 230        | 2008          | 30         | 1         | 0                       | 0                    | 1                     |
|          | 18 Aug         | 230        | 2008          | 30         | 2         | 0                       | 0                    | 1                     |
|          | 18 Aug         | 230        | 2008          | 30         | 3         | 0                       | 16                   | 0                     |
|          | 18 Aug         | 230        | 2008          | 30         | 4         | 0                       | 0                    | 1                     |
|          | 18 Aug         | 230        | 2008          | 15         | 9         | 0                       | 0                    | 1                     |

\* corrected clock by -2 minutes for #11 and #8

### **3.1.1 Turbine Sensor Data**

Data from the DAS have indicated six direct strikes to turbines and many extremely close hits. Table 3 shows a portion of the data associated with the detected strikes. The data are displayed in this table along with the time (local time at the site) and date of the event and the applicable turbine number. Item 2 is a documented strike. Item 1 might have been a strike to unit 11, but the video system was a scanning unit and it missed it. (We did pick up a flash coming onto the viewing area at that time, though.) Item 3 is a strike very close to unit 5 as evidenced by the video record. We used this observation to increase the strike sense threshold slightly in year 2. It is interesting to note that every other turbine sensed some ground current activity at the same time of this event. We saw this pattern (i.e., many turbine sensors responding to the same event at one unit) repeating frequently with surges and nearby strikes.

The counts in each of the data columns can be multiplied by the scalars in Table 1 to indicate the level of activity. Essentially, any non-zero value in the voltage channel is conducted lightning. Also, the neutral current signal is a counter for ground current activity exceeding the indicated threshold (Table 1). The ground signal is a rough indicator of charge going through the ground conductor. Note that in Table 3 the ground sensors from nearby turbines indicate ground activity.

From this data we can discern that, on July 27 at 16:31 p.m., turbine 11 was hit by lightning and the peak lightning current through the sensor was about 5 kA. Since this represents 25% of the current (through one of four legs of the tower), the total strike current was approximately 20 kA. Thirty seconds later, turbine 1 was struck by lightning, giving more counts than is possible with a single strike (120 maximum). The video indicates that the strike was made up of three distinct strokes with three pulses. It is clear that the sensor electronics integrated the counts from all three pulses. Again, our intent was not to exactly detail the peak current, but instead to log that a strike had, in fact, occurred.

### **3.1.2 Strike Video Data**

There are four videos of strikes. Three of these have been digitized and they will be included with this report on a CD. There is another strike suspected but due to the scanning camera configuration in the first year, this was not captured to tape. Interestingly, almost all of the documented strikes were taken by unit #1. Unit #2 was also struck. Both of these turbines are at the south end of the wind park, where most storms first enter the site.

### **3.1.3 ESID and Stormscope Data**

Data from the ESID was streamed into the DAS computer once per minute over a serial communication connection. The data is voluminous and far too extensive to present in this report (see sample in Table 2). However, there were more than 65 separate storms in the 1997 season, and more than 83 storms in the 1998 season. Note that the system was on-line from July to October 1997 and May to October in 1998.

The site operators found the Stormscope system extremely useful because they could replay the previous two days' data on a polar RADAR-type scope. This allowed them to view what turbines the storms went through and when. It was quite useful to see whether or not there was lightning activity when a particular turbine went down or the SCADA system went off-line.

For data processing, the Stormscope system was typically used to view the intensity of strikes during periods when activity was detected with the sensors. The lightning storms followed standard paths as they progressed to and through the site. The storms mostly moved from south to the southeast, usually late in the day.

### 3.2 CSW Site Damage History

The number of lightning events and lightning-related turbine downtime sustained by the Z-40 turbines in Fort Davis are detailed in Table 4. Downtime is categorized as lightning-related if (1) the event started during or immediately following a documented thunderstorm, (2) faults or component damage typical of lightning-related events were evident; or (3) test data were available to identify lightning as the cause. The last two columns show the combined repair and fault downtime in total and per turbine on the site.

**Table 4. Fort Davis Lightning Damage**

| Period    | Lightning Damage Events | Repair Downtime (hrs) | Lightning Faults | Lightning Fault Downtime (hrs) | Combined Lightning Downtime |                   |
|-----------|-------------------------|-----------------------|------------------|--------------------------------|-----------------------------|-------------------|
|           |                         |                       |                  |                                | Total (hrs)                 | Per Turbine (hrs) |
| 7/96-6/97 | 12                      | 1800                  | 78               | 1000                           | 2800                        | 233               |
| 7/97-6/98 | 11                      | 1500                  | 5                | 76                             | 1576                        | 131               |
| 7/98-6/99 | 5                       | 300                   | 23               | 129                            | 429                         | 36                |

The data in this table support the observations of the field personnel that the retrofits were successful in reducing lightning damage. Inspection of the damage to one turbine that occurred in June 1999 revealed that installation of the recommended mitigation measures was incomplete in the turbine's nacelle.

**Table 5. Lightning-Related Faults and Downtime by Site for 1999**

| Site       | Number of Turbines | Repair Downtime (hrs) | Faults (suspected) | Fault Downtime (hrs) | Total Downtime per Turbine (hrs) |
|------------|--------------------|-----------------------|--------------------|----------------------|----------------------------------|
| Fort Davis | 12                 | 742                   | 1                  | 110                  | 71                               |
| Searsburg  | 11                 | 449                   | 0                  | 0                    | 41                               |
| Algona     | 3                  | 20                    | 14                 | 130                  | 54                               |
| Springview | 2                  | 525                   | 0                  | 0                    | 262                              |

### 3.3 Other TVP Site Damage

Table 5 and Table 6 detail lightning damage to turbines at the various TVP sites during 1999 with summaries of outage time and component damage details, respectively. The repair downtime in Table 5 refers specifically to the time the turbine was down because of lightning damage that required repairs. Other faults required a reset only. The majority of the 742 hours of repair downtime at Fort Davis can be attributed to the failure of two power supplies for which spares were not available on site. The 110 hours of faults (the total of all 12 turbines) was primarily due to lightning causing controller problems at night. No damage was done, but resets were not performed until the following morning.



**Table 6. Lightning Damage Detail**

| Project Location | Turbine No. | Date of Event | Hours Down | Affected System      | Damage  |
|------------------|-------------|---------------|------------|----------------------|---|
| Fort Davis, TX   | 12          | 6/22/99       | 13.2       | Controller           | Resistor network protecting SCADA                                     |
|                  | 2           | 6/22/99       | 729.0      | Controller           | 2 power supplies, 2 pressure transducers;                             |
| Searsburg, VT    | 9           | 7/15/99       | 0.2        | Controller           | Intermittent SCADA communication                                      |
|                  | 2           | 7/16/99       | 1.5        | Controller           | Intermittent SCADA communication                                      |
|                  | 2           | 7/19/99       | 3.3        | Controller           | Intermittent SCADA communication                                      |
|                  | 7           | 7/29/99       | 2.2        | Hydraulics           | Hydraulic contactor   |
|                  | 9           | 7/30/99       | 13.5       | Controller           | Lan-A1 and two pressure transducers                                   |
|                  | 1           | 7/30/99       | 371.5      | Controller           | Extensive damage  |
|                  | 10          | 7/30/99       | 43.7       | Controller           | Power supply and input control board #1                               |
|                  | 7           | 7/30/99       | 12.5       | Controller           | Replaced SCADA communications card                                    |
|                  | 11          | 7/30/99       | 0.7        | Controller           | Lan-A1 and SCADA modem  |
| Algona, IA       | 2           | 6/9/99        | 19.8       | Controller           | ICB1 circuit board and wind vane                                      |
| Springview, NE   | 1           | 7/2/99        | 140.7      | Controller           | CPU board, matrix boards, output controller board, rotor driver board |
|                  | 2           | 7/15/99       | 384.2      | Rotor/<br>Controller | Blade failure, CPU, and gear box temperature sensor                   |

The Searsburg project suffered major damage to 3 turbines in July 1998. A picture of catastrophic blade damage to unit 7 is shown in **Figure 3**. This was removed and replaced by Zond. The blade damage on the other two units was repaired without removing the blades. The GMP Searsburg project also experienced several lightning-related problems in 1999, including extensive damage to a controller on turbine 1. At Algona, the primary lightning-related problem was a fault condition in such noise was generated on the serial communication line between the pitch controller and the main controller. In Springview, a blade was struck by lightning resulting in catastrophic failure, which Zond replaced quickly. At the same time, and on one other occasion, the turbines in Springview suffered damage to the controller and power electronics, which also took time to repair because spare parts were not available.



**Figure 3. Damaged Zond Z40FS blade at GMP site**

The Searsburg site experienced a second blade failure from a direct lightning strike on January 11, 2000, as shown in **Figure 4**. The Big Spring project was not fully operational until late in 1999, so it is not included in these tables. Also, the Wisconsin turbines did not suffer any appreciable lightning damage or downtime, presumably because of the protection afforded by very tall communications towers nearby, integral blade protection (conductors), and good shielding techniques in the turbine controls.

### 3.4 TVP Retrofits

The surveys conducted by MLI and LTI on the Zond Z-40A, Z-40FS, and Z-50 turbines at the respective sites generally concluded that their lightning protection was not sufficient, and numerous recommendations were made for retrofits. The results of the review of the Tacke turbines in Glenmore and the Vestas turbines in Big Spring showed that these turbines had adequate lightning protection.



**Figure 4. GMP/Searsburg Z40FS blade strike damage**

One of TVP’s primary findings was that the Zond turbines had no blade conductors, except for the Z-40A, which has an aluminum push rod in the blade to actuate the ailerons. The Tacke and Vestas turbines both had blade conductors designed for lightning protection. Both of the Zond turbine models without blade conductors have suffered lightning-related blade damage. Zond developed and tested a retrofit for the Z-50 blades in early 2000, and installed conductors in Algona and Springview that spring. Schematically shown in Figure 5, Zond’s “Lightning Guard I” conductor retrofit consists of a copper tube fed through the interior of the blade, held in place with expanded foam blocks, and connected to surface-mounted air terminals at the blade tip and the hub.

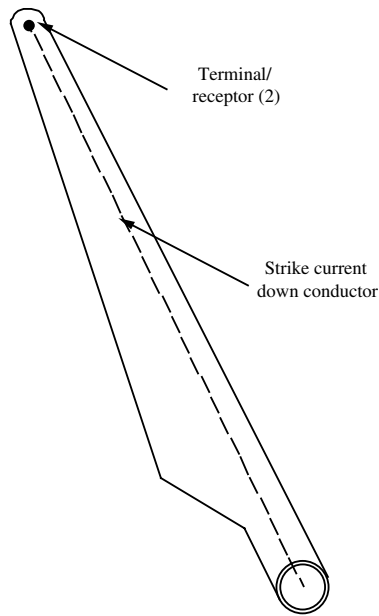

**Figure 5. Zond blade conductor retrofit**

A variety of other retrofits were identified and implemented on the TVP turbines. These included improvements to the turbine grounding and the controller cable shielding. Additional modifications were made to the Z-50s in Algona and Springview and to the Z-40A turbines in Fort Davis. The recommended modifications to the Z-40FS turbines in Vermont are similar to those shown for the Z-50. The details of these retrofits are described in Section 6.

### **3.5 Results from IVPC**

Twenty-eight of the strike sensors were installed throughout a field of over 200 turbines at the IVPC site near Montefalcone East of Napoli, Italy. These were integrated into a Second Wind central turbine monitoring system to document strike damage. The strike sensors used in the CSW field test were matured and modified for this application. A mounted sensor on a turbine at IVPC is shown in Figure 6. This matured version was later installed on turbines at selected TVP sites.



**Figure 6. Strike sensors at IVPC**

IVPC allowed us use of this data to help analyze the distribution of strikes and the possible payback periods of retrofit blade and turbine protection. We received monthly reports from their processed SCADA data whether or not there were strikes. In some instances we used maintenance reports and further inquiries to verify that an actual strike occurred. We have also used their historical maintenance records to document strike events. The lightning strike events that were documented and attendant repair costs are listed in Table E-1 in Appendix E. They are summarized annually in Table 7.

The lion's share of damage occurred on blades that have had to be replaced or repaired in the field. An example of typical blade damage is shown in Figure 7. Events that did not result in blade damage usually had some amount of downtime until the turbine could be inspected and the controller reset. In some such cases, sensors may have taken damage, but the repair cost was usually low compared to events with blade damage. It is interesting to note that as the population of turbines increased, the frequency of events experienced (per turbine) stayed in the same range of 6–8%.

IVPC estimated that *in situ* blade repair costs were about \$1900 including boom truck and labor. When a damaged blade was replaced, the cost was about \$45,000, and this included a new blade, half a day for a significant crane, and personnel time. Note that downtime is not included in these estimates.



**Figure 7. IVPC/Vestas blade damage**

The economics of these events are not as one would expect. In fact, the result would be not to retrofit the turbines that do not have blade protection systems. It would appear to be cheaper (at this site with these turbines) to bear the cost through the repairs. This is because frequently these events are cheaper than the deductible of project insurance [normally in the range of \$250,000 to \$500,000 (US) for large projects].

The protection systems in place on the IVPC site and the more than 200 Vestas 660 kW turbines are described in Section 5, and the complete version of the above statistics are in Table E-1 in Appendix E.

**Table 7. IVPC Blade Damage and Repair Statistics**

| Year  | Events | Blades   |          | Average Turbines in Operation | Per year |               |              | Estimated Repair Cost | Cost per Turbine in Operation |
|-------|--------|----------|----------|-------------------------------|----------|---------------|--------------|-----------------------|-------------------------------|
|       |        | Replaced | Repaired |                               | Events   | Blade Replace | Blade Repair |                       |                               |
| 1996  | 1      | 1        | 0        | 17                            | 5.7%     | 5.7%          | 0.0%         | \$45,000              | \$2,577                       |
| 1997  | 6      | 2        | 3        | 72                            | 8.3%     | 2.8%          | 4.2%         | \$95,700              | \$1,330                       |
| 1998  | 8      | 1        | 6        | 134                           | 6.0%     | 0.7%          | 4.5%         | \$104,500             | \$778                         |
| 1999  | 18     | 2        | 4        | 229                           | 7.9%     | 0.9%          | 1.7%         | \$97,600              | \$427                         |
| 2000* | 22     | 3        | 18       | 284                           | 7.7%     | 1.4%          | 6.3%         | \$253,500             | \$891                         |

\* Year 2000 complete only through September

## 4 Literature Review

There is a significant amount of literature on lightning protection practices and the design of lightning protection systems. However, there is little discussion of up-to-date, application-specific considerations. Lightning protection according to existing standards<sup>9,10,11,12</sup> and available literature<sup>13,14,15</sup> as they apply to wind turbines are useful and helpful guides, but their use still results in significant lightning damage as documented by University of Manchester Institute of Science and Technology (UMIST) researchers<sup>16</sup>, DEFU<sup>8</sup>, and IEA experts<sup>17</sup>. These indicated that damage due to lightning is the most costly type of downtime event. Even if these events are not as frequent as others, the repair costs and lost revenues can strongly affect WTG operation costs, especially in high lightning-risk areas.

Following is a description of pertinent standards for lightning protection and a summary of useful literature. For additional research, more in-depth resources are listed, as well as a report on a short course on lightning protection.

### 4.1 Existing Standards

#### 4.1.1 ***“Standard for the Installation of Lightning Protection Systems,” NFPA 780***

NFPA 780<sup>9</sup> is from the standards group that maintains the National Electric Code, and it is geared to installation details. However, this has little bearing in the protection of wind turbines because it is focused specifically on buildings and similar structures. In fact, in the scope “electric generating, transmission, and distribution systems” are specifically excluded.

#### 4.1.2 ***“Protection of Structures Against Lightning,” IEC 61024***

IEC 61024<sup>10</sup> is the primary standard for lightning protection of structures in Europe. The International Electrotechnical Commission maintains this and other lightning specific standards under TC81. It is an extremely useful document for design and maintenance of lightning protection systems. This is especially true with sizing down-conductors and ground electrodes. There is also good rationale for using structural metal as “natural” conductors.

Specific to wind turbines, the standard (as of 1999) has not addressed “tall structures” – those above 60 meters (196.8 feet) are excluded. Also, in the scope “electric generating, transmission, and distribution systems external to a structure” are excluded. Nonetheless, the standard is a strong design tool for general lightning protection.

I recommend that any serious designer of lightning protection systems for wind turbines get a copy of all parts of IEC 61024.

#### 4.1.3 ***“The Assessment of Risk Due to Lightning,” IEC 61662***

IEC 61662<sup>11</sup> is used to assess the risk of lightning damage in terms of personnel safety or cost. Procedures are provided to perform these analyses.

#### 4.1.4 ***“Protection Against Lightning Electromagnetic Impulses,” IEC 61312***

IEC 61312<sup>12</sup> is a five part standard focused on protecting against damage to communication and other low voltage systems. The use of lightning protection zones, as a first line of defense, is well defined in Part 1. In fact, it is suggested that lightning protection systems can be made quite robust and efficient if;

- Items at risk are properly embedded into zone areas
- Good shielding is used to transition into higher zones of protection
- Correct bonding is installed at zone boundaries.

Surge protection devices are discussed thoroughly in Part 3 and somewhat in Part 1. Part 1 also has a useful appendix on the waveforms that are expected at an installation and the fundamental differences with waveforms used to test devices.

I recommend that anyone interested in designing lightning protection systems for wind turbines get a copy of IEC 61312-1.

#### **4.1.5 “Grounding of Industrial and Commercial Power Systems,” IEEE 142- 1991**

IEEE 142<sup>23</sup> is somewhat outdated, but it describes good practices for any power system especially those contained completely by a building. It is concerned with primarily 60 Hz fault safety.

#### **4.1.6 “Guide for Safety in AC Substation Grounding,” ANSI/IEEE 80 – 2000**

IEEE 80<sup>18</sup> is a very good guide for the extremes that utilities go to in providing operator safety in the event of faults in substations. Because of its familiarity, it is also the first reference most utility distribution designers reach for when asked to assess the grounding systems on a wind farm. The practices described are appropriate for substations, i.e., contained, restricted-access facilities. However, the guidelines will not always improve safety when applied over large wind plant installations.

## **4.2 Wind Turbine Specific Literature**

### **4.2.1 “How to Protect a Wind Turbine from Lightning”**

A thorough literature search on applicable lightning protection to WTGs was carried out by Dodd, McCalla and Smith<sup>13</sup> for the DOE. This report, commissioned by the National Aeronautics and Space Administration (NASA) in 1981, contains many valuable instructions on how to protect against lightning damage, and it is recommended to all turbine or site designers and operators.

The authors did a laudable job of describing the unique risks and issues with trying to protect a wind turbine from lightning damage. The document methodically describes the risk and offers solutions presented in the existing literature for all components and subsystems at risk. The section on protection of electronics is the best in any of the literature that I investigated.

### **4.2.2 “Lightning Protection of Wind Turbine Generator Systems and EMC Problems ...”**

The International Energy Agency (IEA) has done a good job of convening meetings of experts on particular areas of concern in wind energy system in the past 20 years. This 26<sup>th</sup> experts meeting was on wind turbine lightning protection convened in Milano, Italy, by the Italian National Electricity Group (ENEL) and the Danish Technical University, and this document<sup>17</sup> was the proceedings of this meeting. Several informative Italian papers were presented on strike current distribution through a turbine structure, through bearings and through wind turbine blades. There is a great need for further investigations on these important, and still poorly understood issues.

Nonetheless, there is good research and good reporting presented in the dozen or so papers in this document. In fact, this meeting resulted in an effort to develop a consensus document of recommended practices. Such a document was developed<sup>19</sup>, but it is significantly overshadowed by the IEC 61400-24 document that it essentially gave birth to.



### **4.2.3 “Lightning Protection for Composite Rotor Blades”**

This report by H.W. Gewehr<sup>15</sup> was delivered at a conference in 1980, and it was well ahead of its time. Most of the approaches described were used in helicopter blades and aircraft at some time, and they seem rather expensive and complex for wind turbine applications. However, the blade protection approaches offered were used successfully in the MOD turbines.

## **4.3 Recent Wind Turbine Specific Literature**

Recent additions to the literature include the following application-specific documents. All of these documents are publicly available in English, and it is recommended that these be acquired by anyone truly interested in wind turbine lightning protection. The only gaps in the lightning-protection considerations in these documents is probably in personnel safety.

### **4.3.1 “Wind Turbine Generator Systems, Part 24: Lightning Protection,” IEC 61400-24**

The strength of IEC61400-24<sup>7</sup> is in the careful explanation of the use of the standards listed above (as well as others) with the distilled experience of experts in the field. Also, a thorough analysis of statistics of lightning damage to wind turbine populations in Denmark and Germany is well presented. A very good set of recommended practices for all phases of wind turbine design and development is included except, perhaps, for a step-by-step approach to low-voltage circuit protection.

This is one of the best publications on the subject of wind turbine lightning protection. It is an extremely useful document for wind turbine designers, purchasers, operators, and developers.

### **4.3.2 “Lightning Protection of Wind Turbines - A Designers Guide to Best Practices”**

The very capable researchers (Cotton et al) in the high voltage group at UMIST in Manchester, England, have written a very useful document<sup>16</sup> for the wind turbine designer. They have been extensively researching blade protection, bearing damage simulation and grounding (or earthing, as the British refer to it) since the mid 1990s with European Commission and UK Department of Trade funding. They have been working with turbine manufacturers and operators, other high-voltage labs, and the National University of Athens. Their wind turbine application-specific research is unique.

As mentioned, the document reports on some of UMIST's bearing damage simulation research. While not definitive, they deal with it quite well given the paucity of information in this realm. They also have been extensively investigating grounding methods and verification specific to wind. Their work is well considered and clearly reported. I suspect that a search of more recent literature with their names on it will provide more up-to-date lightning protection research.

### **4.3.3 DEFU, Recommendation No. 25, “Lightning Protection of Wind Turbines”**

Troels Sorenson at the Danish Electric Utilities Research Institute (DEFU) in Lyngby, Denmark, has done a good job of bringing the current understanding of lightning protection to bear on wind turbines in this fine white paper<sup>8</sup>. His writing is simple, precise, and to the point. He covers the whole protection approach for all wind turbine system elements, including risk assessment.

## **4.4 More In Depth Literature**

### **4.4.1 Fisher and Plumer, “Lightning Protection of Aircraft”**

Fisher and Plumer<sup>20</sup> wrote the definitive tome on the lightning protection of aircraft under contract to the Federal Aviation Administration (FAA). Lightning Technologies has been updating the publication and

keeping it in print. This is an extremely thorough approach to the subject, and there area of expertise closely approximates wind turbine applications. All recommendations are backed up with solid research and exhaustive referencing.

#### **4.4.2 Uman, “The Lightning Discharge”**

Martin Uman <sup>22</sup> is one of the foremost atmospheric physicist/phenomenologist on the subject of lightning in the United States. There are several paperback books for the lay reader and some hefty textbooks for the serious researcher on the subject. And, of course, the current literature abounds with his contributions.

#### **4.4.3 Golde, “Lightning, Volume 1- the Physics of Lightning”**

Golde <sup>21</sup> is credited with first turning a researcher’s hard eye to the subject of lightning protection. He accumulated the state of the art of knowledge on the subject in the 1950s and laid down the foundation for much of the research to date.

### **4.5 Lightning Protection Course**

There are several available courses in lightning protection throughout the United States including Lightning Technologies (LTI), the National Lightning Safety Institute, Georgia Tech, and Mississippi State University. I selected Lightning Technologies due to their proximity and the timing of the course.

#### **4.5.1 Summary**

During May 14 and 15, 1997, I participated in a 2-day course on “Lightning Protection of Facilities” given by Andy Plumer of Lightning Technologies, Inc. in Pittsfield, Massachusetts. The course covered the subjects of lightning formation, estimation of strike probabilities, protection of structures against direct strikes, and the protection of systems against indirect effects. It was a well-presented course taught by a renowned expert in the field of lightning protection using thorough course material. After the course, I spent an hour talking with Mr. Plumer asking wind turbine specific questions. Also, I talked at length with the high-voltage lab test engineers regarding details of our sensor testing.

#### **4.5.2 Lightning Technologies, Inc.**

LTI is a consulting and engineering firm with a great deal of experience in research, development, design, and testing of lightning protection systems and installations. The principals of LTI are former GE High Voltage Laboratory engineers. The engineers participated in the start of GE’s lab in the 1960s, and they splintered off when the lab was closed in the 1970s. Much of their experience and focus is on the protection of aircraft and avionics (commercial and military) from lightning damage. Apparently the FAA requires all commercial avionics to demonstrate protection against a 200 kA (8  $\mu$ s /20 $\mu$ s) pulse. LTI has one of the few laboratories in the country approved by the FAA for this type of testing. A partial list of LTI’s projects/customers include Disney World, the Stealth bomber, the U.S. Capitol building in Washington, and the FAA.

The people in this laboratory impressed me with their competency in operating their facilities and the thorough knowledge of their subject matter. They were quite careful about noting when they were stating opinion, observation, or currently accepted (in the literature) explanations.

Andy Plummer’s expertise is in protection of aircraft against direct strikes and indirect effects from the conducted currents. He has tested enough models and equipment to know where lightning is going to strike. He has also performed a great deal of forensic analysis on damage to aircraft and structures.

## 5 TVP Site Surveys and Lightning Risk

Occurrences of lightning damage are a function of the lightning activity in the area, the height and prominence of the turbine installation, the terrain, and the lightning protection system in place. The risk for the TVP sites is discussed below, followed by documentation of the protection systems to ensure proper comparison of lightning damage at the difference sites.

### 5.1 Lightning Activity at TVP Sites

As noted previously, the modern era of wind energy development originated in locations where lightning activity is relatively minimal, and the risk and frequency of damage to wind turbines is low. In California and Northern Europe, where the majority of the world's wind development occurred before the mid-1990s, lightning is relatively rare. For example, there are on average 10 thunderstorm days per year in Denmark, and there are less than 4 annual thunderstorm days in much of California.

Figure 8 depicts the distribution of thunderstorm and lightning activity in the United States. The stars on the Figure 8 map indicate the TVP sites. In contrast to the early wind development areas, six out of the seven TVP projects were installed in areas where frequent lightning activity is indicated. A typical local report of the measured lightning flash density (strokes to ground per square kilometer per year) for the TVP site in Big Springs, Texas, is shown in Figure 9.

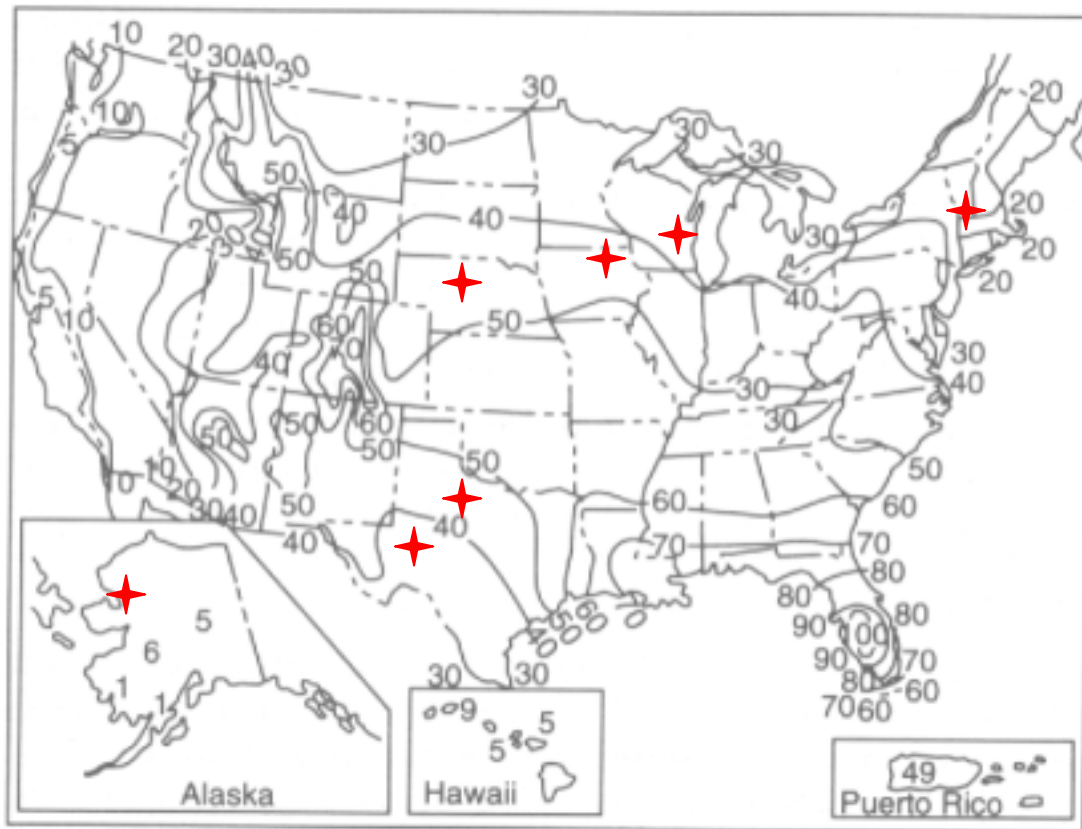
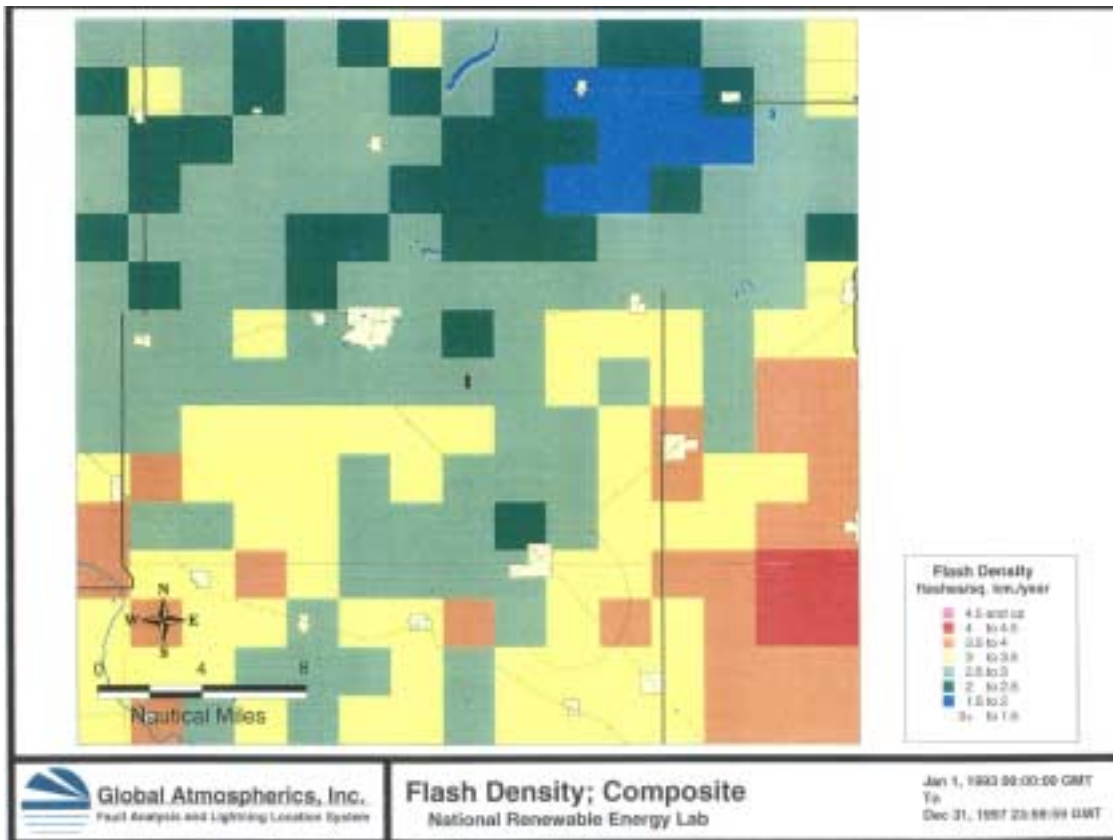

Figure 8. Mean annual thunderstorm days in the United States

## 5.2 Lightning Risk at TVP Wind Sites

Lightning strike risk is a function of local thunderstorm frequency and turbine equivalent strike collection area. Table 8 details the lightning risk at the seven TVP wind sites as determined from National Weather Service data (80-year database) and reports from Global Atmospheric based on the National Lightning Detection Network (NLDN) database statistics on lightning-strike density (5 to 8 year database). As can be seen, the sites in Vermont, the Midwest, and Texas have considerably more thunderstorm activity than the typical California site.



**Figure 9. NLDN lightning flash density report for Big Springs, Texas**

The equivalent strike collection area is the sum of the areas for each wind turbine described by the base of a cone with a radius equal to three times the maximum blade-tip height (or hub-height plus rotor radius). The estimated number of strikes per year is calculated from the flash density and the strike collection area, and the average number of strikes per turbine is based on the number of turbines at the site. It should be noted that the strikes to the site may be attracted to just one or two turbines because of their prominent location. This was observed at the CSW site where four of six observed strikes were to unit 1.

Table 8 shows that the first two TVP projects installed, Fort Davis and Searsburg, have moderate lightning risk compared to the more recently installed sites in Glenmore, Algona, Springview, and Big Spring. This is due to the higher heights and effective collection areas per turbine. The Wisconsin project has been in operation for more than two years and, although it is in a relatively high-risk area, its lightning problems have been minimal. It is suspected that the proximity of three tall communications towers adjacent to the Glenmore site provide a degree of protection to the turbines there.

**Table 8. TVP Lightning Strike Risk**

| Site                | Thunderstorm Days/Year | Ground Flash Density (stroke/km <sup>2</sup> /yr) | Strike Collection Area (km <sup>2</sup> ) | Estimated Turbine Strikes/Year | Est. Average Strikes per Turbine per Year [1] |
|---------------------|------------------------|---|---|--------------------------------|---|
| Fort Davis, TX      | 41                     | 3.0   | 0.65                                      | 1.9                            | 0.16  |
| Searsburg, VT       | 25                     | 1.5   | 0.57                                      | 0.9                            | 0.08  |
| Glenmore, WI        | 36                     | 1.75  | 0.30                                      | 0.5                            | 0.25  |
| Algona, IA          | 43                     | 2.5   | 0.40                                      | 1.0                            | 0.33  |
| Springview, NE      | 44                     | 2.5   | 0.35                                      | 0.9                            | 0.43  |
| Kotzebue, AK        | 1                      | <0.2  | 0.25                                      | <0.05                          | 0.0   |
| Big Spring, TX      | 40                     | 2.0   | 4.55                                      | 9.1                            | 0.20  |
| Typical CA site [2] | 4                      | 0.25  | 0.16                                      | -                              | 0.04  |

[1] Estimated Turbine Strikes per year divided by the number of turbines at the site

[2] Based on a single 50-m-diameter rotor with 50-m hub height in Tehachapi

### 5.3 Survey of Lightning Protection at GMP Site

The following are notes and observations on the lightning protection as installed on the eleven Zond Z40FS turbines at Green Mountain Power’s Searsburg, Vermont site. This protection includes conductors to ground to earth the lightning current, bonding to minimize arcing of lightning currents, shielding to reduce induced voltages in sensor wires and delicate electronics, and, finally, transient voltage surge suppression to protect electronics.

#### 5.3.1 Turbines and Site

As mentioned, there are 11 Zond Z40 turbines on this site owned by GMP, DOE, and EPRI. The site is near Searsburg, Vermont, and the turbines are distributed along a steep ridge at an altitude of 600 meters (2,000 feet) AMSL (above mean sea level). The lightning risk is moderate at this location.

These are 40-m (131ft) rotor diameter, full-span, pitch-controlled turbines rated at 550 kWe. The rotors have three blades. The towers are tubular steel, and the control system is in the base and at the tower top.

#### 5.3.2 Blade Protection

1. There is no conductor in or on the blades, nor an air terminal at the tips to take the strikes.
2. “Experience with unprotected fiberglass blades in service is that they do suffer lightning strikes at a disturbing rate, and that such strikes are generally catastrophic, causing blade destruction. In these instances, the arc is generated on the inside of the blade, and the shock/explosive overpressures associated with the high-energy component of the lightning strike result in the damage. The lightning arc is often found to puncture through the center of the blade by formation of an arc channel through drain holes at or near blades tips, or through cavities, flaws, and bond lines. It is probable that the presence of moisture and dirt in the blades or in cavities can assist the formation of a current path. The explosive vaporization of moisture will contribute to the pressure increase and damage to the blade.” This is from the IEA protection guidelines<sup>19</sup>.

### 5.3.3 Ground Paths and Equipotential Bonding

To clarify some of the details described in the following, see the turbine plan view and profile in Figure 10 and Figure 11. It may also be helpful to look at the site layout shown in Figure 12.

1. Base control box has 4Ø insulated bond wire from its top to a near point on the tower.
2. Generator ground connects between ground bus in lower right of high-voltage (480 VAC) side of control box and the generator case (4Ø SO).
3. Generator ground also goes between generator case and tower at mid-section just below the droop clamp (4Ø SO).
4. Air terminal (lightning rod) is mounted above aft end of generator on nacelle cover (fiberglass) 1.5 m (5 ft) up. Lightning conductor is 4Ø SO bonded only at tower midpoint just below droop clamp (120° clockwise from generator ground conductor). Should bond to generator at closest point.

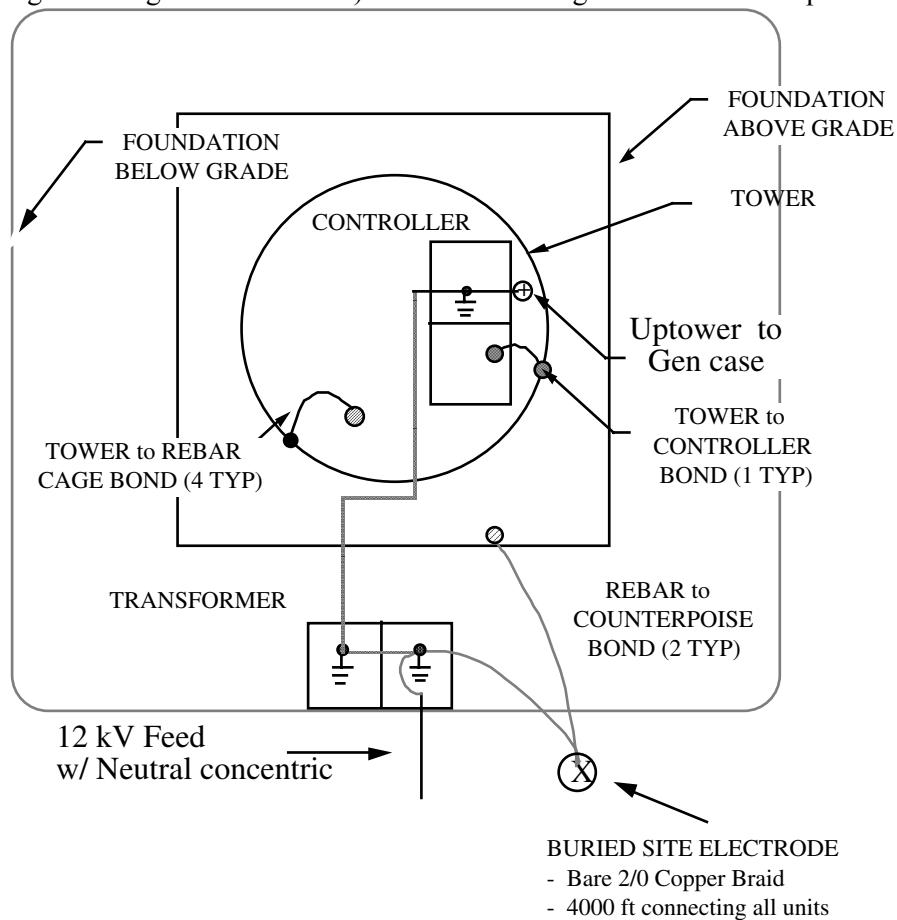
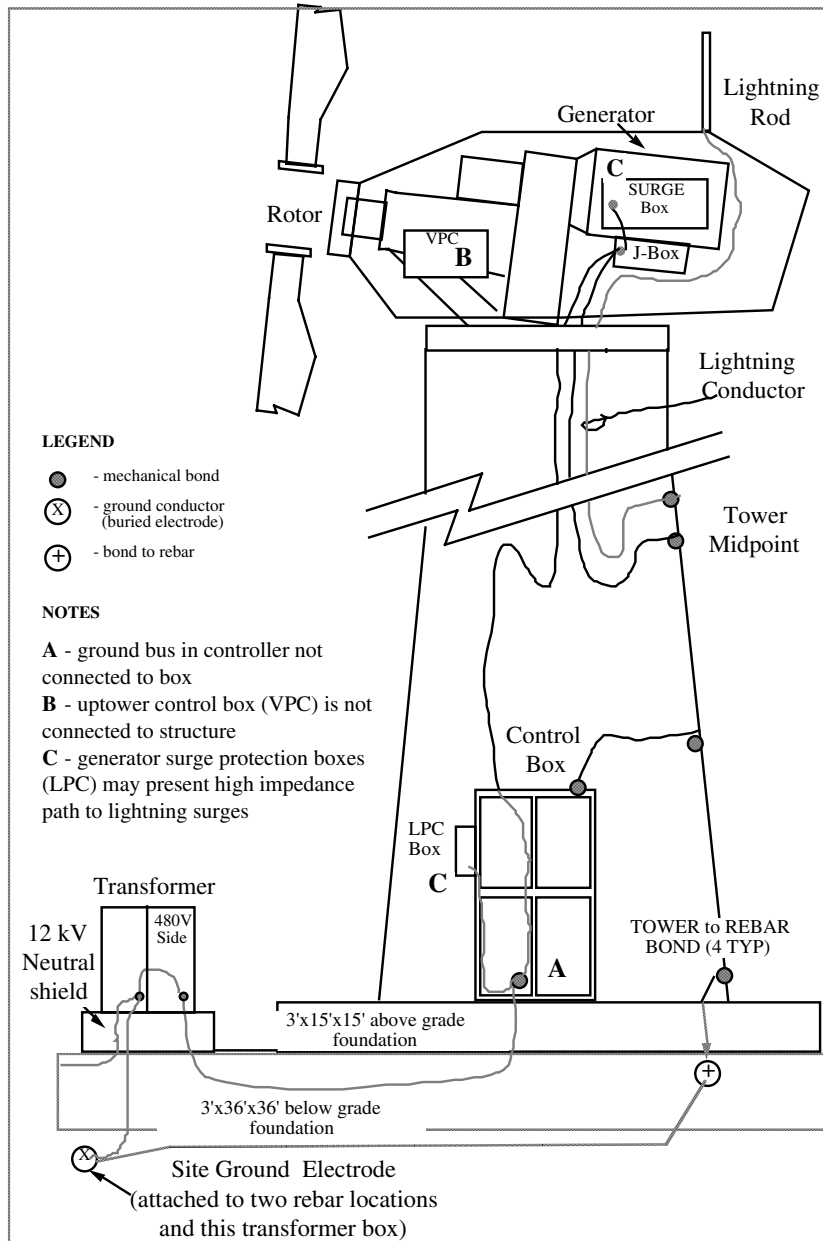

**Figure 10. GMP - Zond Z40 FS - grounding scheme**

5. Ground straps (2Ø bare braid) bond between tower base and foundation rebar at 4 radial locations. All indications are that the rebar is not augmented with a Ufer ground (coil of copper braid at base of foundation).

6. A ground strap (2Ø bare braid) is connected between the transformer secondary case and the controller ground bus (see item 2).

7. Each turbine has a separate transformer (wye-wye, 12 kV to 480 V), and its primary is conducted with concentric neutral braids on all three conductors. These braids are terminated on a ground bus on the primary side of each transformer case. A bare conductor (2Ø bare braid) is buried in the feeder trench (direct burial in crushed granite and gravel) throughout the whole site to augment the ground. This is probably 1.2 km (4,000 ft) of buried conductor. All transformer ground buses are connected to this counterpoise by 2Ø bare braid.



**Figure 11. GMP/Zond Z-40FS grounding and bonding**

8. This site counterpoise is connected to the neutral conductor coming up from the substation at the point of common coupling (a Y in the road where the feeder splits). It is also connected to the turbine

foundation rebar cages, typically at two corners closest to the road with a 2Ø bare conductor. Some turbines are connected at only one point to this site counterpoise.

9. No counterpoise (buried or surface grounding ring or grid to diffuse lightning currents) seems to exist at each turbine.

#### **5.3.4 Shielding**

1. The nacelle cover is glass reinforced polyester (GRP) with no metal content. No shielding is associated with this.

2. The steel tower should be the first level of shielding. As soon as wires enter the tower, no further shielding is needed because the lightning current will be conducted by the metallic tower to the earth. As such, the shields and ground wires should be terminated on entry to the tower (i.e., at droop wire clamp below gearbox).

3. The steel variable pitch controller (VPC) box is the first level of shield for any sensors that conduct to it or any controller cards or devices inside it. LTI recommends terminating shields at both ends (i.e., at the sensor and the VPC box).

4. Control and sensor wire shields and braids should be terminated at both the VPC and the base controller.

5. At any exposed areas in nacelle, sensors should also have an overbraid covering the wires. (In places where the termination of sensor shield wire causes any signal problems, remove the shield at the sensor but ensure that overbraid is complete from sensor to VPC.)

#### **5.3.5 VPC Protection (uptower control box)**

1. All sensors go down to the motherboard via the VPC terminal strip.

2. Sensor shields are not grounded at the VPC. They are made common to other shields and continued to base. This is bad practice because the combined shields may cause coupling between sensors.

3. Not all shields are terminated at base. Those that are terminate only at the ground strip (bottom center of control box). They should be terminated as soon as they enter box.

4. The VPC box is not bonded to turbine frame or anywhere else. It is mounted on rubber vibration mounts that stand the box off from the gearbox by about 19 mm (0.75 in.) (see Figure 11). The ground path is assumed to be in sensor or control wires and shields to sensor housings or base controller. It is recommended that the VPC be bonded to the local frame in at least two places.

5. No surge protection is offered to any sensors, the operator interface terminal (OIT), or the modem that negotiates communication with the motherboard in the downtower control box. It was unclear if there is surge protection on the PC boards.

#### **5.3.6 Base Controller Protection**

1. Ground bus on the 480 VAC side of box is on insulated standoffs, and at no point is it connected to the control box. It is recommended that this be bonded directly to the control box, making the whole control box the single point ground (SPG).



2. The sensor terminal strip should have direct-mounted lugs for grounding shields to box. Currently they must travel to the terminal strip, through wireways to the un-bonded ground bus, and finally into the rebar. Bonding these shields directly at the entry to the box keeps unwanted current arriving in the shield from being conducted inside the box along other control wires in the wire-way

3. An isolation board is between most sensors and the controller card rack. This appears to be opto-isolation and signal conditioning for temperature probes and other sensors.

4. Custom 120 kA surge suppressors are installed at the three phase terminals (to SPG) in the controller and at the terminals in the generator junction box.

### 5.3.7 SCADA

The site layout is shown in Figure 12.

1. Full foil shields on SCADA communication wires are not terminated to ground anywhere.
2. Pedestal junction boxes (near units 4, 7, and 8) have shields ganged together but not to ground.

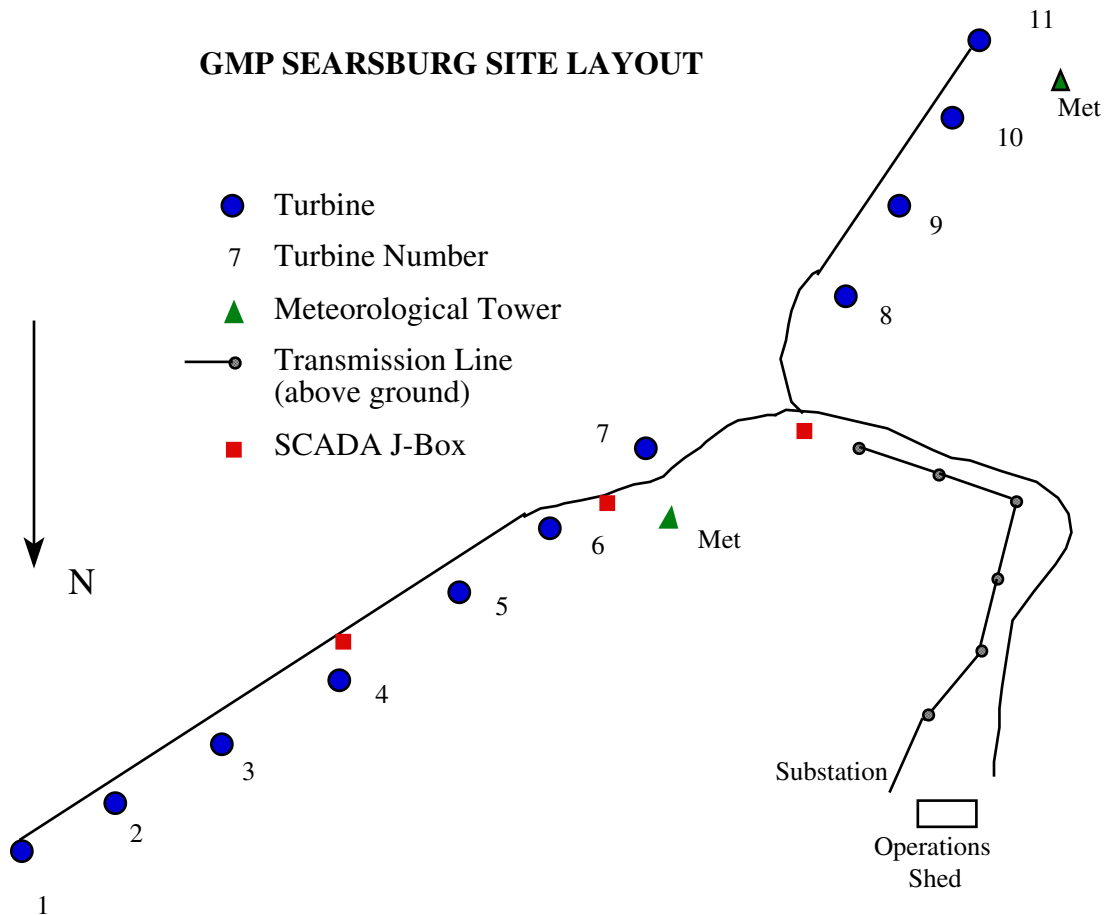

Figure 12. GMP site layout

3. The only protection for clamping surges is gas-tube, spark-gap arrestors, which still allow 200-V transients to continue to the modems and SCADA multiplexer. Spark-gaps exist at turbine and before SCADA computer.

## **5.4 Survey of Lightning Protection at the CSW Site**

A site grounding and lightning protection survey was conducted and documented for the Zond Z40A turbines on the CSW site near Fort Davis, Texas. The blade control and the site design result in some differences with the protection system documented for the GMP turbines and site. Rather than repeat all the information from the previous section, I have described the differences in the CSW site in this section.

### **5.4.1 Turbines and Site**

As indicated, there are 12 Zond Z40A turbines on this site owned by CSW, DOE, and EPRI. The site is near Fort Davis in West Texas, and the turbines are distributed along a ridge at 1500 meters (5000 feet) AMSL. The lightning risk is very high on this site.

These turbines were the first 12 production units of the Z40, 40-m (131-ft), 550-kWe turbines manufactured by Zond. They are outfitted with blade ailerons instead of the full-span pitch used in the GMP turbines. The rotor has three blades using controlled actuation of 20% of the blade surface to limit torque. The towers are steel truss, and the control system is in the open on pads near the tower base and at the tower top.

### **5.4.2 Blade Protection**

The Zond Z40A turbines use ailerons to limit rotor torque and assist in stopping the turbine rotor as needed. The aileron surfaces are actuated with a hub mounted linkage system attached to push rods in each of the three blades. The hinges of the aileron act as an effective air terminal to receive the strike, and the aluminum push rod and hub linkage provide a continuous down conductor for the lightning strike current.

### **5.4.3 Grounding**

The grounding details are described for a typical turbine in Figure 13 and Figure 14. The grounding electrode was significantly modified with a retrofit designed by Rich Kithill at the National Lightning Safety Institute (NLSI). Some observations of the details follow:

- Each of the four tower legs are tied to a ground wire inside the concrete pier (Ufer ground).
- Each tower leg is connected by copper braid to a ring electrode [30.5 m (100 ft) of 2/0].
- Two of the tower legs are connected by 2/0 copper braid to 46 m (150 ft) of 38 mm (1.5 in.) copper strap buried in irrigated bentonite laid out in 0.9 x 15 m (3 x 50 ft) radial crow's feet (irrigated twice a month).
- All 3 phases of the 25 kV buried site feeder has a common braid terminated at each turbine transformer box (primary side).
- The air terminal (lightning rod) on the nacelle has insulated 4/0 Cu welding cable conducting to the ground braid (no bond to tower).
- The generator J-Box (generator ground) is connected by insulated 4/0 Cu conductor to a tower bond 1.5 m (5 ft) from base (below sensor) and control box.
- The controller path to ground is either via the neutral cable or via the feeder transformer box into a ground rod and the ring electrode.
- The controller and uptower generator surge protection device clamps to SP ground.

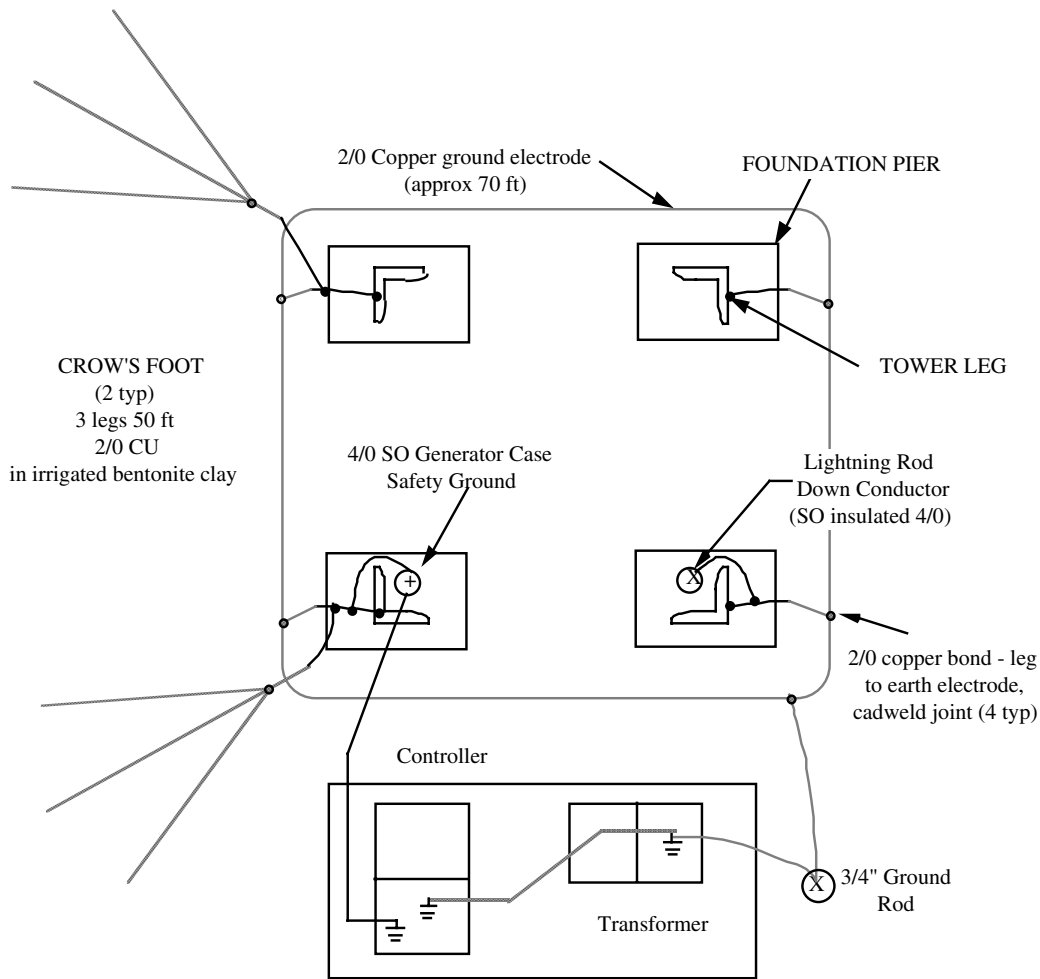

**Figure 13. CSW turbine grounding plan view**

#### **5.4.4 Other Differences to GMP Turbines**

It appears that the utility line and the communication system are the major catchments for damage due to indirect effects (e.g., surges induced by nearby lightning elevating local potential). The site distribution is conducted by an overhead line 27 km (17 miles) to a substation near Marfa, Texas. This line brings a lot of surges into the site. Because of the poor grounding at the line poles (hardpan soils), the surges find their best path to ground at these excessive grounding systems at each turbine. Also, the SCADA wiring topology is a star system that connects all turbines back to the SCADA computer at the operations building. The SCADA then becomes a pathway to equalize potential between turbines and the operations building.

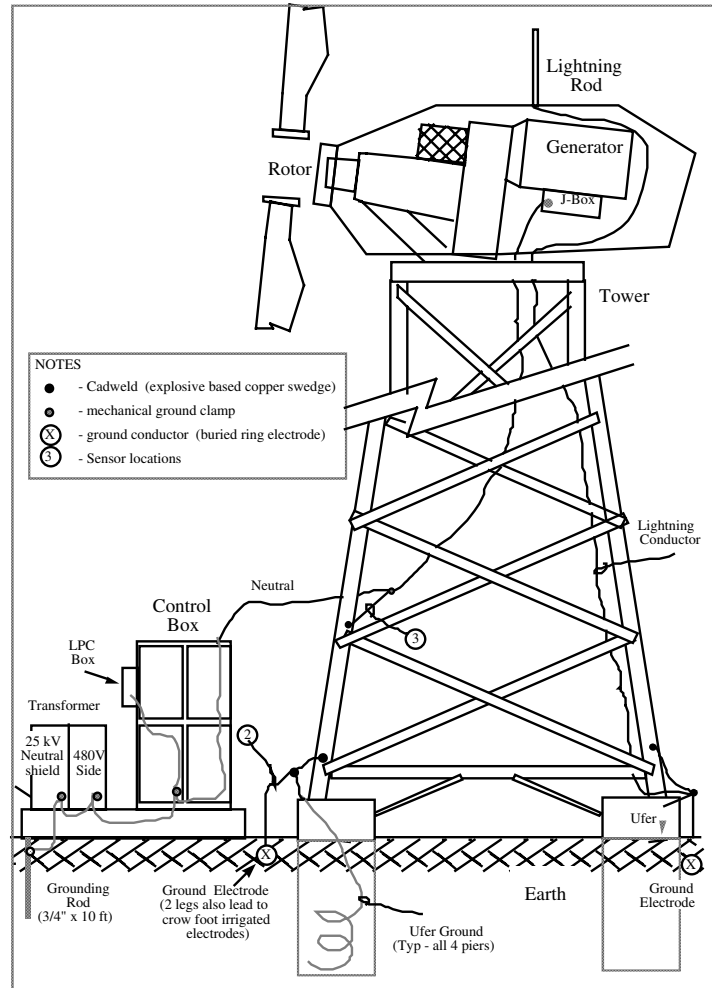

**Figure 14. CSW turbine grounding - elevation**

## 5.5 LG&E/ Kennetech Site in West Texas

LG&E operates 35 MW of Kennetech turbines north of Van Horn, Texas, near the New Mexico border. MLI was asked by DOE to visit this site to determine what sort of lightning protection support might be contributed to LG&E's operating group.

### 5.5.1 Turbines and Site

There are 117 Kennetech KVS 33 turbines on the site. These are 33-m (108-ft) rotor diameter, full-span, pitch-controlled turbines rated at 300 kW. The rotor has three blades. The towers are tubular steel, and the control system is in the base and at the tower top. The project is situated in a high-wind regime on a steep ridgeline. The site is exposed to frequent lightning activity, and it takes quite a bit of maintenance to keep the systems on-line during lightning season (April to September).

### 5.5.2 Blades and Nacelle

There are no blade conductors in the Kennetech fiberglass blades. They have taken dozens of strikes that have led to catastrophic blade failures, and, unfortunately, replacement blades are difficult to acquire due to the Kennetech bankruptcy. Also, there is neither a lightning rod nor metal in the nacelle cover that would afford protection for operators. It is recommended that such a system be instituted.

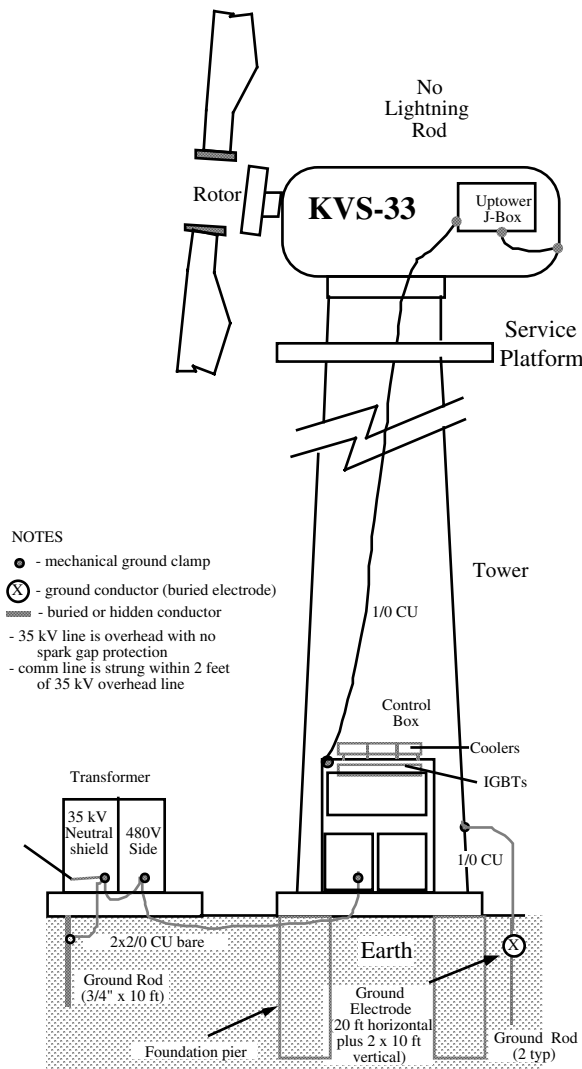

Figure 15. KVS-33 grounding scheme

### 5.5.3 Grounding and Bonding

The grounding system is inadequate for the dry soil at the site, and the bonding practices were observed to be poor. Figure 15 shows the grounding scheme. Some observations follow:

- There is a horizontal electrode of 1.5 m x 1.5 m (5 ft x 5 ft) at each turbine with 0.6 x 3 m (2 ft x 10 ft) ground rods.
- Integrated gate bi-polar transistors (IGBT) are used in the power electronics. These can fail frequently due to surges, and they are protected by metal oxide varistor (MOV) and 650V spark-gaps.
- A more thorough external spark-gap system on each pole is recommended to ground much of the transients before they enter the controller. Also, an MOV rated to at least 20 kA is recommended at the secondary input of the downtower controller.
- More thorough bonding of control boxes and tower steel is recommended.

### 5.5.4 Shielding

Wires in the nacelle, despite being exposed to the full lightning strike current and electromagnetic effects, are poorly shielded. No metallic wireways, and little or no shielding or surge protection was observed on sensor wires. A moderate amount of overbraid shielding could keep sensors from being damaged along with the uptower control computer.

### 5.5.5 Communication System

An uptower control box provides run-time control for the turbine, including pitch control and shutdown response. This unit communicates with the downtower controller via fiber optic. The downtower controller provides main contactor and power electronics control.

A SCADA system operates the turbines using a multi-drop serial connection to each turbine. This daisy chain approach included hard copper wiring throughout the site. The layout is described in Figure 16. This system has surge protection, but the wiring is not adequately protected from direct and indirect effects. It lacks good zone-by-zone protection methods, and site operators report that parts of the SCADA system are frequently damaged by lightning. This results in losing communication with turbine groups until it can be debugged. Damage is also frequently taken in the multiplexer inputs.

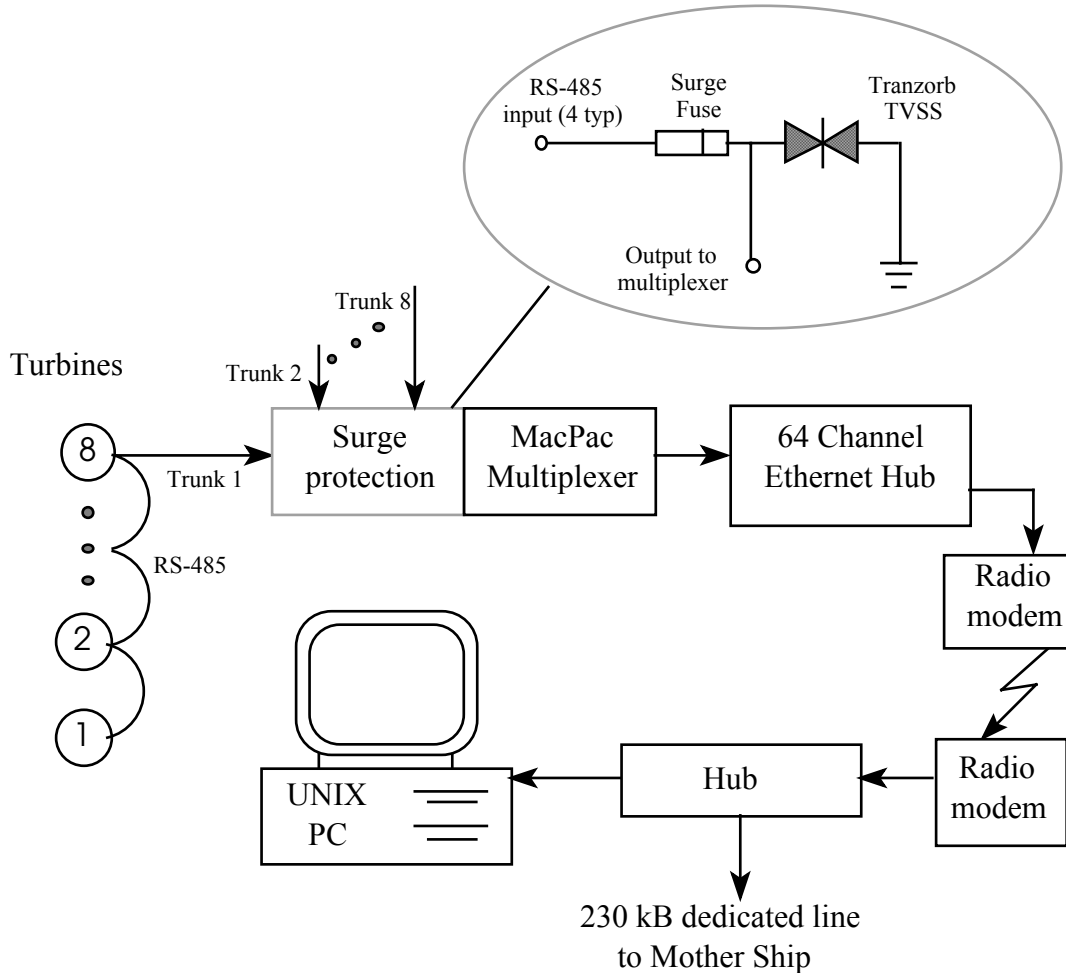

Figure 16. KVS-33 site communication system with surge protection detail

The system could be greatly improved by terminating the trunk line shielding at both ends and providing higher energy, but slower spark-gap devices in advance of the transient voltage surge suppressors (TVSS). Some impedance would be required between these two components in order to allow the spark-gap device to act before the cascading diode. Another TVSS across the transmit and receive pairs would also disallow any common mode differentials to pass damaging currents to the multiplexer components.

## 5.6 Algona, Iowa Site

A consortium of Iowa utilities installed three Zond Z-750 turbines with 50-m (164-ft) rotors in Algona, Iowa. These 750-kWe units are mounted on 50-m (164-ft) tubular steel towers in a high lightning-risk area of north-central Iowa. The area is flat, and the turbines are a rather prominent part of the terrain. The turbines are connected directly into the local distribution system. The turbines are three-blade, full-span pitch rotor. The controller allows variable speed operation of the rotor.

### 5.6.1 Blades and Nacelle

There were no blade conductors in the originally supplied Zond Z-50 blades. However, internal conductors were retrofit in 1999. This retrofit included tip terminals 600 mm (23.6 in.) inboard from the tip with copper tubing as the conductor to guide the strike current to the blade root (see Figure 5).

There is little or no metal in the nacelle cover that would afford protection for operators. However, there is a lightning rod that provides a moderate amount of protection for personnel and meteorological instruments on the nacelle. The rod is not connected to the local turbine steel. Instead, it is connected to the midpoint of the tower via a droop cable (4/0 CU insulated SO), as is the generator safety ground.

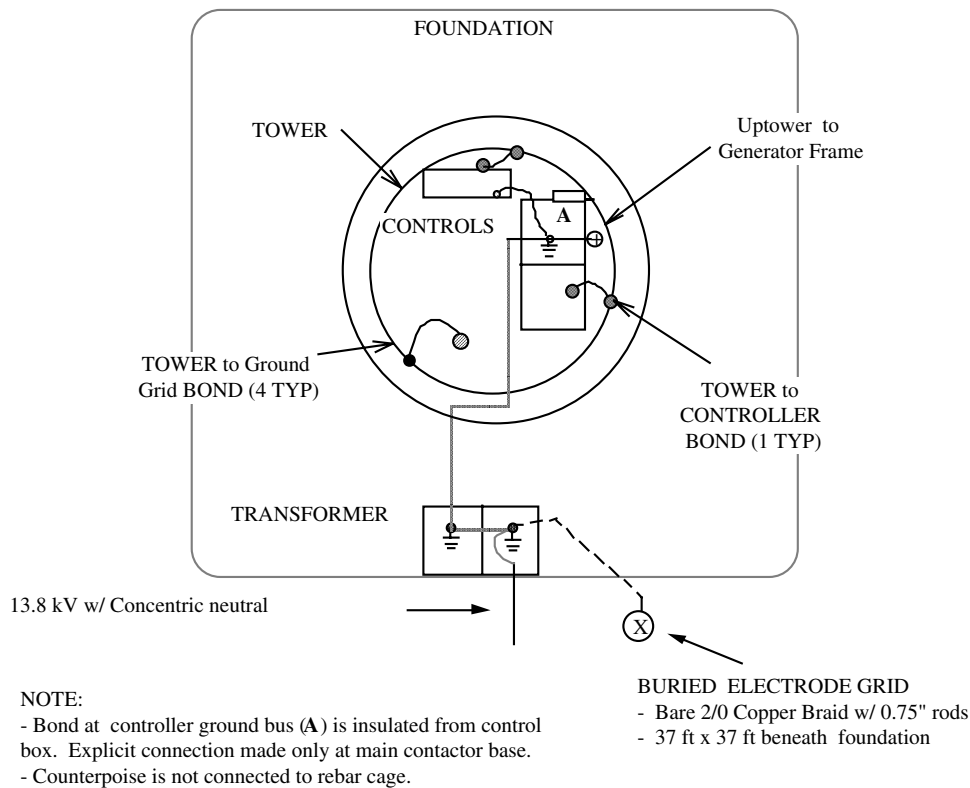
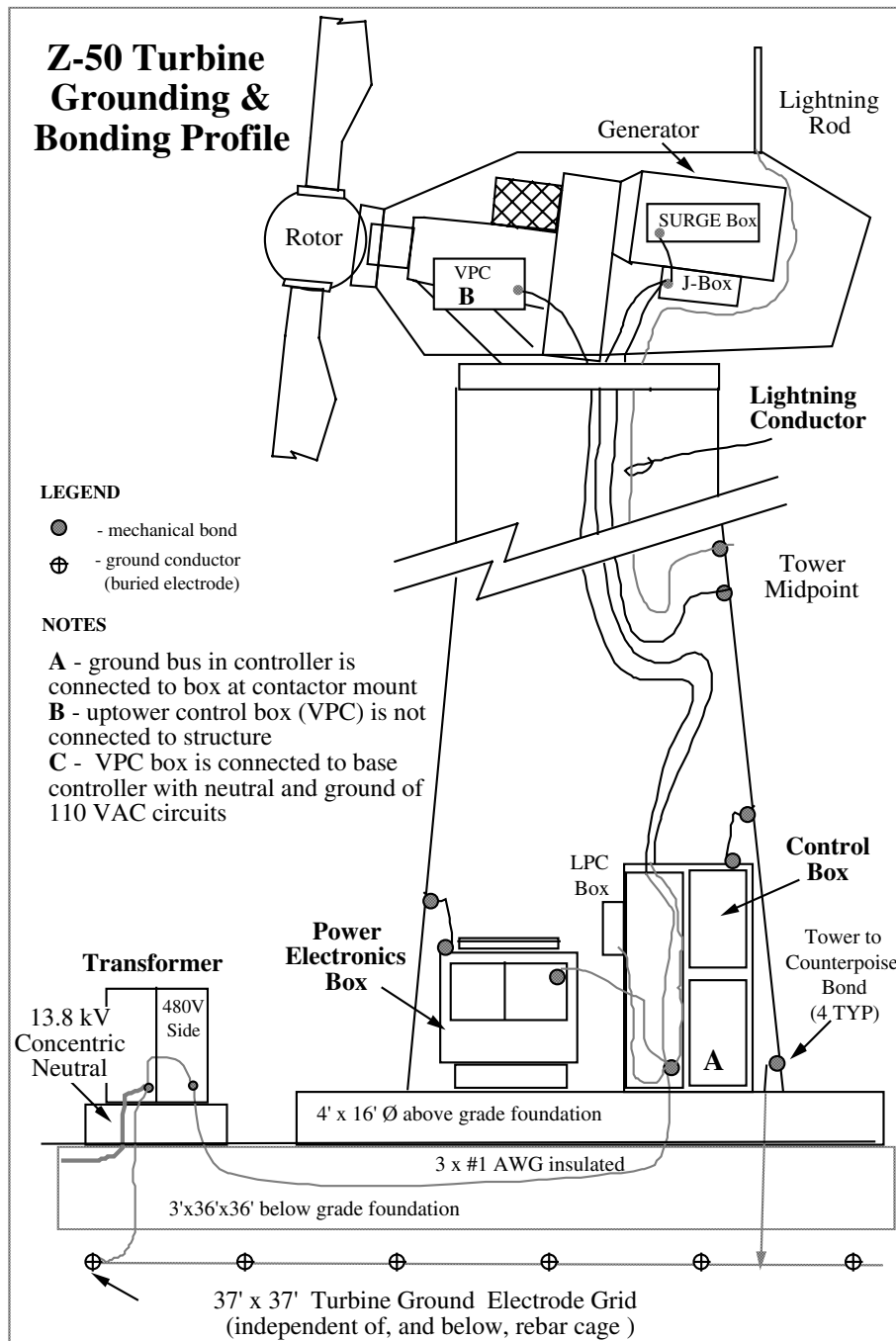

Figure 17. Algona Z-50 grounding details



**Figure 18. Algonza Z-50 grounding and bonding profile**

### 5.6.2 Grounding and Bonding

The grounding system is good, but the in-turbine bonding practices were observed to be poor. Figure 18 and Figure 17 show the grounding schema. Following are observations regarding the grounding system:

- There is a grid of 1/0 CU horizontal electrode of 11.2 x 11.2 m (37 x 37 ft) at each turbine 1.2 m (4 ft) below grade.
- This grid is not connected to the rebar cage inside the foundation concrete.



- The pole that drops the mains to the site has IEEE Class C spark-gap protection.
- The tower is connected to the buried ground grid at four locations.
- The control box and power converter box are inside the tower, and they are bonded to the tower.
- The generator safety ground is connected from the case to the control box SPG (insulated from steel cabinet).
- A 120-kA surge protection MOV system is connected to the stator wires at the generator junction box, and another is mounted on the downtower controller.
- The VPC or uptower control/junction box is on insulated (vibration isolation) standoffs, and it is not bonded to the local structural steel. During a strike, this would allow a significant potential difference between this control box (and the items in it) and the rest of the tower top. In this case, any sensor connected to it has the risk of being the bonding path – thereby destroying the low-impedance devices at the heart of most sensors (gauge bridge, etc).

### 5.6.3 Shielding

Wiring in the nacelle is poorly shielded. No wireways or overbraid provide protection from direct strike current or inductively coupled loop currents from nearby conduction. Most sensor shields are connected directly through the generator or VPC junction boxes and conducted directly to the down tower control box. There they are terminated at the single point ground (SPG) bar, which is inside, but insulated from, the control box. Instead this SPG finds its path to ground via three buried #1 AWG wires (insulated) connected to the transformer case, which is outside the tower about 9 m (30 ft) away. This case is then connected to the buried grounding grid. This carries the SPG concept to an absurd extreme. Instead, these items should all be bonded to the control cabinet so that it becomes the SPG. This keeps any stray currents away from sensitive electronics in the cabinet.

### 5.6.4 Communication System

A Second Wind monitoring system is installed on each turbine with cellular telemetry to the Algona local utility office. This appears to be well protected with MOVs and a sacrificial resistor network on the sensor inputs and the communication line.

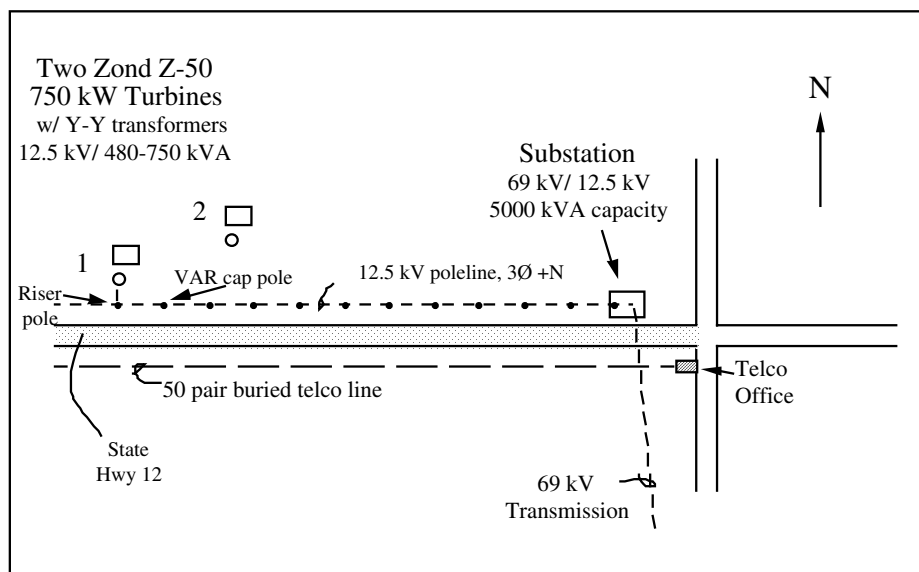

Figure 19. NPPD site layout

## 5.7 NPPD Site

The Nebraska Public Power District (NPPD) installed two 750 kW Zond Z-50 turbines 3.2 km (2 miles) west of the center of Springview, Nebraska. The two turbines were the first Zond Z-50 units installed on 65 m (213 ft) truss towers, and they are connected to the local distribution system (12.5 kV). Figure 19 is a site layout.

It should be noted that the blade protection, bonding, shielding, and surge protection issues are identical to those in Algona because they are essentially the same turbines. The difference in the two systems lies in the truss tower arrangement and the grounding system.

### 5.7.1 Grounding System

The controller, power converter, and transformer boxes are mounted outside on a concrete pad separate from the truss tower base, and, as shown in Figure 20, the ground electrode is a ring surrounding the foundations and the controller pad. The boxes and all the foundation legs are bonded to the ground electrode with a bonding strap. The incoming 12.5 kV primary has concentric overbraids that carry the return current and are bonded to the transformer case. The control system SPG bus is also connected to the case of the transformer.

This arrangement allows for significant circulating current in the 480 VAC ground conductors. We solved this problem by removing the isolation mounts on the controller SPG and thereby bonding it to the control box.

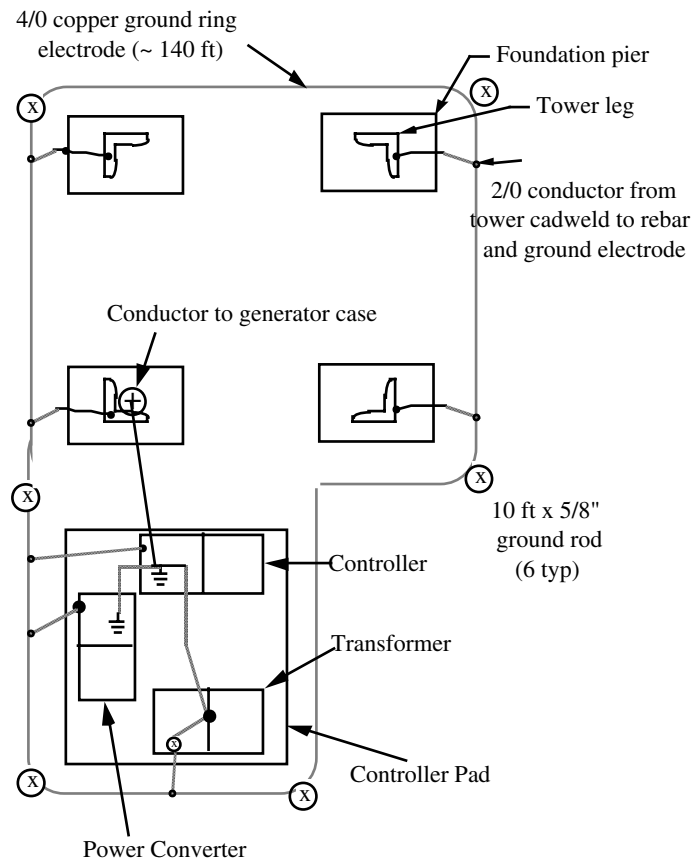

Figure 20. NPPD Z-50 grounding scheme

## 5.8 IVPC Site Survey

A trip was made to the Italiano Vento Power site east of Milano, Italy, in September 1998. Their Vestas turbines had taken some damage from lightning, and we wanted to include them into our database from the TVP projects. A Second Wind monitoring system includes strike sensors to help document the lightning activity.

### 5.8.1 Turbines and Site

At the time of this survey, there were 200 Vestas 42-m (138-ft) and 44-m (144-ft) turbines distributed along the steep ridges of a very high lightning-risk area in south-central Italy. The three-blade, pitch-controlled turbines were mounted on truss towers of different heights. The turbines were rated between 600 and 660 kWe, depending on their installation date.

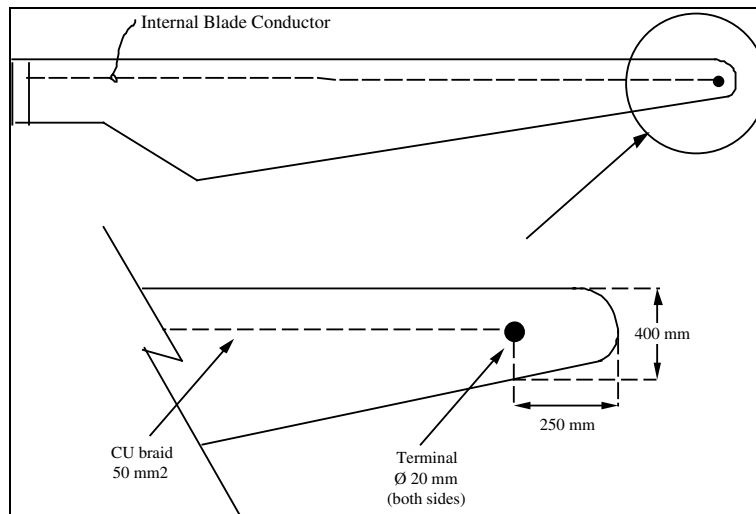

Figure 21. IVPC Vestas V44 blade protection

### 5.8.2 Blade Protection

The fiberglass blades have threaded inserts at the root to accept mounting bolts into the pitch bearing. A 50 mm<sup>2</sup> (No. 1 AWG) copper lightning down conductor from each tip is glued periodically to the inner surface of the blade. It is attached to one of the threaded inserts at the root and bonded to the inside of both blade terminals 250 mm (9.8 in.) inboard on either side of the tip (see Figure 21). These 20 mm (0.7 in.) diameter stainless steel terminals are mounted flush with the outer surface of the blade skin and are intended to receive the lightning stroke and safely conduct it to ground (see Figure 22). These are installed during blade manufacture.



**Figure 22. Vestas V44 blade protection receptor/terminal**

### 5.8.3 Grounding and Bonding Considerations

These installations were equipped with a rather significant earth electrode (see Figure 23) to terminate and dissipate lightning strokes to the wind turbine structure. The electrode in the ground is 50 mm<sup>2</sup> (No. 1 AWG) copper installed in a pair of loops about the tower foundation and the control house buried at about 1 m (3.3 ft). It amounts to over 50 m (164 ft) of electrode with 6 ground rods (vertical electrodes) of 16 mm by 2 m (0.6 in. by 6.5 ft). The primary high-voltage conductors are buried in a trench with a bare conductor that connects the adjacent grounding electrodes.

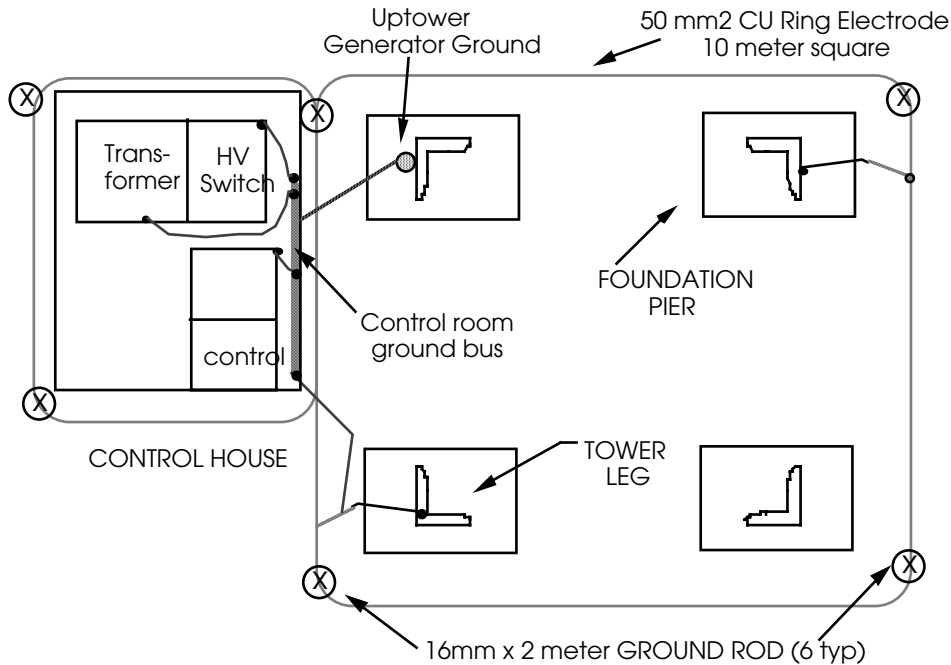

**Figure 23. IVPC Vestas V44 grounding**

The generator case is bonded across the base isolation mounts to the frame below, and a safety ground is conducted to the SPG in the base control room. The generator case is also bonded to the 40 m (131 ft)

tower at a location 15 m (49 ft) down from the top using 2 x 25-mm<sup>2</sup> (No. 4 AWG) copper conductors in the droop cable. This is common practice, presumably to help the strike current bypass the yaw bearings. Because of the high inductance of the conductors; however, the bearing path is still the low impedance pathway for the strike current.

#### 5.8.4 Surge Protection

The turbine is well thought out in terms of surge protection. The following locations have surge protection to protect the electrical system and assure operator safety:

- The drops from overhead lines to underground conductors have spark-gap devices
- The primary side of the transformer has enclosed 120 kA fused spark-gap devices on each phase
- The generator connection box has 15 kA MOV type devices to clamp surges to ground
- The low voltage controller has a Dehn “Blitzconductor” KT multilevel system for surges across and on the 24 VDC and 220 VAC system
- Communication between tower base controller and tower top is done with fiber optic
- The Second Wind monitoring system has a custom Telco interface with 20 mm MOV, cascading diodes and resistors. The latter are sacrificial and easily replaced.
- The tower top controller also has a Dehn “Blitzconductor” KT multilevel system for surges across from incoming sensors (especially anemometer and wind vane).



Figure 24. IVPC/Vestas V44 nacelle protection

#### 5.8.5 Operator Safety Considerations

The nacelle cover is constructed of fiberglass panels mounted into a metal cage. This cage is well bonded to the structure, and it provides good protection to personnel inside the nacelle during lightning activity. The top of the nacelle has a series of horizontal rods along the upper perimeter that are probably intended

for safety (see Figure 24). These also provide additional protection from direct strikes to people inside the nacelle. They are also well bonded to the structure.

#### **5.8.6 Shielding Considerations**

Sensor and control wires throughout the nacelle are well routed along wireways or through structural channels. Wire shields are well terminated immediately at entry to all metal boxes. The uptower control cabinet is well bonded to the structure.

### **5.9 York Research Site**

The York Research site near Big Springs, Texas, is an adjunct TVP participant, and it has an array of Vestas V60 (1.6-MWe) and V46 (660-kWe) turbines. MLI did not visit this site to do a survey of the lightning protection. However, York Research consulted with MLI about whether or not the installed grounding was sufficient to provide protection.

The foundation is shown in an overhead view in Figure 25. It was constructed by installing two concentric sheet steel tubes (like culverts) into a drilled 4.5 m (15 ft) diameter hole in the existing soil to depths of 8.2 m (27 ft). Concrete was poured in the vertical (annulus) space between the culverts along with lined foundation bolts. A ground ring was buried outside this foundation at about 0.76 m (2.5 ft) deep. This grounding ring is bonded to the outer culvert, the tower (twice), vertical ground rods (four locations) and the distribution line ground. This is a good grounding system design for both personnel safety and strike dissipation for the hardpan soils in West Texas.

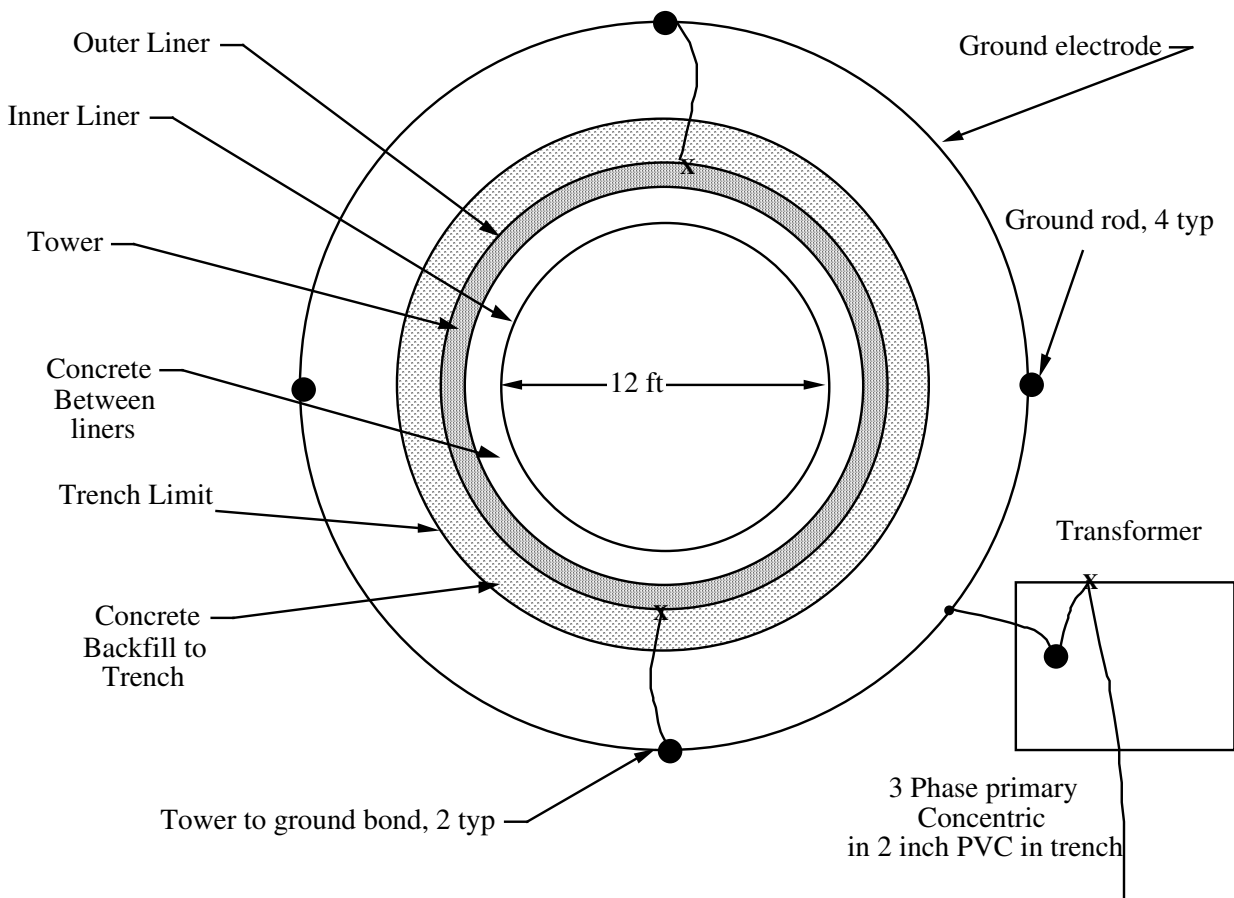

Figure 25. Big Springs/York research grounding detail

## 6 Lightning Protection Retrofits

### 6.1 Recommended Modifications to Zond Z40

McNiff Light Industry worked with Keith Crouch and Andy Plummer of Lightning Technologies, Inc. (LTI) to help improve the lightning protection at TVP sites. LTI was brought in after damage was taken at the GMP Searsburg TVP site in Vermont (Zond Z40 turbine). They were also brought in to evaluate the NPPD turbine protections at the Zond factory while the turbines were being assembled. The following modifications to the two types of turbines were offered. Please refer to the lightning protection site surveys for diagrams and explanations.

#### 6.1.1 Initial Zond Z40 Lightning Protection Modifications

The following modifications were initially instituted on Zond Z-40A units 1 and 2 at the CSW wind park in Fort Davis, Texas, in 1998. Retrofitting two turbines helped us verify the effectiveness of these changes by doubling the probability of lightning impact on modified units. It should be noted that these protection changes are also applicable to the GMP turbines.

#### **6.1.1.1 Tower Top Modifications**

1. Connect the nacelle lightning rod base plate directly to the generator housing via AWG No. 4 equivalent (or larger) tinned copper braid. There is a 15.875-mm (5/8-in.) unused hole on the bottom of the plate and similar unused holes on the standoff bracket on the aft end of generator. The existing insulated lightning rod conductor may remain in place.
2. Ground the shields (individual as well as overall) of all instrumentation and control cables entering the VPC (from sensors or from downtower) to the VPC backplane or box. Use a bare copper terminal strip connected directly to the box surface (or backplane) as close as practical to wire entry or exit. Also, terminate all unused wires in the same manner; this will provide a form of shielding.
3. Ground the VPC box directly to the gearbox via short, direct bond straps across existing isolation mounts. A ground connection at each end of the box should suffice (i.e., two places) using #4 braid into lugs on box mounting screws.
4. Ground the bottom of the base control cabinet to the tower ground conductors from one side (minimum) of the cabinet with tinned copper braid (use 2-0 because it is outside and exposed).

#### **6.1.1.2 Base Controller Modifications**

5. A ground wire from the secondary of the transformer is connected to the ground bus at the bottom right of the controller 480 VAC section. This ground bus is on insulated stand-offs. Connect the ground bus to the cabinet. A short braid direct from the entering ground conductor to a nearby cabinet wall will suffice, or remove the insulated stand-offs.
6. Ground the overall shields on cables entering from the nacelle area and from outside the tower (e.g., SCADA) to the cabinet. Also ground individual incoming circuit shields to the cabinet. This grounding may be facilitated by installing a copper or brass terminal strip, fastened periodically to the cabinet with self-tapping or threaded screws and nuts, close to the wire entry or exit (above controller card rack).

#### **6.1.1.3 SCADA Protection**

7. Connect the full foil shields of the SCADA communication wire to the control box and the entry (first steel envelope) of the operations room. I suggest stripping back the outer sheath insulation to expose 12.7 mm (0.5 in.) of the foil, attaching a copper ground clamp (two-part type with a wire screw clamp), and connecting between the ground clamp and a termination on the box surface.
8. Overall and individual shields should be jumpered together at the site wide pedestal junction boxes (using the method noted in item 7), so that a continuous electrical path exists along each individual shield and overall shield between the operations building and each tower base controller.
9. Overall and individual circuit shields enclosing the SCADA and any other signal and control circuits entering the operations building should be grounded to the incoming circuit J-box, and the box grounded via fasteners (as exists at present) directly to the building interior metal wall using the shortest practical path. A brass or copper terminal strip fastened to the interior of the J-box would facilitate these ground connections.

#### **6.1.1.4 Materials**

A list of materials is offered in Table 9.



**Table 9. Initial Improvements for Z40 Materials List**

|    | Amount | MATERIALS   | (per turbine) |
|----|--------|---|---------------|
| a. | 25 ft  | #4 AWG tinned copper braid (flat)                 | \$40          |
| B  | 15 ft  | #00 AWG tinned copper braid (flat)                | \$30          |
| C  | 12     | clamp lugs for 1/2" screws (for #4)               | \$15          |
| d. | 6      | Clamp lugs for 2-0 wire (to mount to controller)  | \$35          |
| e  | 4      | Bare copper terminal strip, 12 screw clamps       | \$20          |
| f  | 4      | Ground clamps to connect to existing tower ground | \$15          |
| g  | 6      | Clamp lugs to go over SCADA shields               | \$20          |
| h  | 50     | Box of #8 self-tapping mounting screws            | \$15          |

**6.1.2 Increased Lightning Protection for Zond Z40**

The following modifications were also installed on CSW units 1 and 2. The actual installation details were facilitated by McNiff Light Industry once controller documentation was reviewed with CSW site personnel. Some of these steps required dis-assembly and re-assembly of sensors and sensor wires.

**6.1.2.1 Tower Top**

1. Install overbraid shields on interconnecting wire harnesses around the generator and gearbox, and ground these harnesses via equipment connector backshells or directly to equipment (i.e., transducer, actuator) cases. Hose clamps and wire ties can be used to secure the overbraids around the harnesses and connectors/cases.
  
2. Important sensors for overbraid include the pitch transducer, the pressure transducers, and the proportional control valve. Remove the wires one sensor at a time from the VPC and any raceways, slip the overbraid over the unconnected end until it overlaps the sensor connector, reinstall the wire, and terminate the braids over the connectors at each end (may have to tease the braid weave). If the end connectors are nonmetallic, continue the braid to a metallic structural connection. In the case of the pitch transducer, continue the braid (feed the wire through the braid wall) to allow a hose clamp to attach it to the aluminum sensor cover.
  
3. Install overbraid shields on wind speed/direction instrument cables on top of and inside the nacelle. Ground these shields to the instrument cases (if metal) or the nearest metal support bracket, and to the base plate in the nacelle top skin. Shields of connecting cables within the nacelle should also be grounded to the base plate and to equipment housings at the other ends of these cables.
  
4. Attach three terminal low-voltage spark gaps (Joslyn Model #2022-24 Trigrad) across the sensor wires of the anemometer and wind vane (both Vout to AG and Vexc to AG) in the plastic junction boxes on the aft end of the generator. Terminate the third wire of these devices to an explicit ground termination to a close point on the generator housing (box mounting screw will do).
  
5. Attach bi-directional TVSS from VPC ground to wires in the anemometer (both) and wind vane bundles (Vexc, Vout). This should appropriately exceed the 24 VDC operating voltage of the wind vane.
  
6. Repeat items 4 and 5 for the proportional control valve and the pitch and pressure transducers.
  
7. Repeat items 4 and 5 for the OIT circuit.

**6.1.2.2 Base Controller Shielding and Surge Protection**

8. Install 130 VAC MOVs (Harris # V151DA40) across the service transformer (115 VAC secondary side) between neutral and hot and between hot and ground (the control box backplane). Repeat for controller power supply transformer (115 VAC primary side).

9. May need some additional protection for the 24-volt control power circuit at the top and bottom, presumably spark-gaps and TVSS (30 VDC).

**6.1.2.3 SCADA System**

10. Ensure that all the spark-gap devices at both ends of the SCADA are intact and functional.

**6.1.2.4 Materials**

A list of materials is offered in Table 10.

**Table 10. Increased Protection for Z40 Materials List**

|   | (per turbine) | MATERIALS  |
|---|---------------|--|
| a | 100 ft        | 25/32" tinned copper braid, tubular                        |
| b | 100 ft        | 3/8" tinned copper braid, tubular                          |
| c | 24            | 1" hose clamps, stainless                                  |
| d | 12            | Assort of 1.5" to 3" hose clamps, stainless                |
| e | 25            | TVSS, bidirectional, 28-30 VDC, 1500 W                     |
| f | 25            | TVSS, uni-directional, 28-30 VDC, 1500 W                   |
| g | 25            | TVSS, uni-directional, 15 VDC, 1500 W                      |
| h | 12            | MOV, 22 mm, 130 VAC - Harris # V151DA40                    |
| i | 12            | Spark-gap surge suppression, Joslyn Model #2022-24 Trigrad |

**6.2 Retrofit Recommended to Z-550 and Z-750 Owners**

**6.2.1 MLI Protection Improvement Recommendations for the Z50**

**6.2.1.1 Tower Top Items**

1. Connect the nacelle lightning rod base plate direct to the generator housing via AWG No. 4 equivalent (or larger) tinned copper braid. There is a 15.8-mm (5/8-in.) unused hole on the bottom of the plate and similar unused holes on the standoff bracket on the aft end of generator. The existing insulated lightning rod conductor may remain in place.

2. Ground the shields (individual as well as overall) of all instrumentation and control cables entering the VPC (from sensors or from downtower) to the VPC backplane or box. Use a bare-copper terminal strip connected directly to the box surface (or backplane) as close as practical to wire entry or exit. Also, terminate all unused wires in the same manner; this will provide a form of shielding.

3. Ground the VPC box directly to the gearbox via short, direct-bond straps across existing isolation mounts. A ground connection at each end of the box should suffice (i.e., two places) using #4 braid into lugs on box mounting screws.

4. Provide overbraid over the wires to the ambient temperature sensor, the pitch transducer, and the anemometry. Terminate braids to sensor case and junction box metal at each end.

#### **6.2.1.2 Base Controller Items**

5. A ground wire from the secondary of the transformer is connected to the ground bus at the bottom right of the controller high-voltage section. This ground bus is on insulated stand-offs. Connect the ground bus to the cabinet. A short braid direct from the entering ground conductor to a nearby cabinet wall will suffice, or remove the insulated stand-offs.

6. Ground the overall shields on cables entering from the nacelle area and from outside the tower to the cabinet. Also ground individual incoming circuit shields to the cabinet. This grounding may be facilitated by installing a copper or brass terminal strip, fastened periodically to the cabinet with self-tapping or threaded screws and nuts, close to the wire entry or exit (above and behind controller card rack).

7. Provide MOVs across power supplies for the sensors and control boards (24 VDC).

### **6.2.2 Lightning Technologies Improvement Recommendations for Z50**

#### **6.2.2.1 Blade Protection**

Discussions of blade protection requirements revealed that external conductors often crack or peel due to blade bending and flexing. The turbine uses a three-blade rotor with a lightning rod on the nacelle. It can be assumed that most of the lightning strikes will approach from above. Most strikes will attach to either the nacelle or the blade tips, but some small percentage could hit mid-blade. An internal blade conductor exposed at or near the tip will capture a large number of the strikes. This approach seems to be used exclusively by European manufacturers.

#### **6.2.2.2 Surge Suppressors**

The 480 VAC surge suppressors (one in the downtower control cabinet and one in the generator) were reviewed during the tour. The present LPC device consists of five blue modules/phase. It is rated at 120 kA, which far exceeds the potential threat to the system, either from transients caused by strikes to the wind turbine or the power grid. The generator-to-control box cables are well shielded by the generator/gearbox housing and the truss or tubular tower structure. Currents exceeding 10 kA (8 x 20 us) would be very rare and result from improper cable routing (outside of the tower structure) and omission of bonding cables in the system.

In all of the wind turbine generator installations observed to date, the 480-V cables are connected to a step-up transformer at/near the base of the tower. The transformers are grounded to the tower base and the cables are buried. Again, the configuration is not one that would result in currents greatly exceeding 10 kA being delivered to the base of the tower by the 480 V cables.

It certainly would be appropriate to reduce the rating of the suppressor to, at least, 20 kA and maybe even 10 kA (8 x 20 us). The device installed on the prototype appears more appropriate.

#### **6.2.2.3 Bonding and Shielding**

At present, sensor cables are grounded at the tower base control cabinet, carried through the VPC box (but not connected to it), and stopped at the sensor terminal strip. The shields are open-circuited at this point. In the proposal, the shield will be stopped at the VPC box terminal strip and the shield between the sensor and the VPC box would be connected to the VPC box. In addition, an internal SPG will be

established on the box back plane. This point will be grounded to the box and the box will be grounded to the generator housing at the mounting bracket.

Several other bonding/shielding changes were discussed and will be investigated by Zond. Those consisted of installing a conductor [wire or 12.7-mm (0.5-in.) flat copper braid] in parallel and bundled with the sensor wire harnesses between the sensors and the junction box(es). Initially, this would be applied to the most sensitive (and expensive) units, such as the weather sensors, pitch sensor, and proportional valve(s). The parallel conductor would be bonded to the sensor housing and the junction box(es).

Another change consisted of tying the lightning rod cable to the generator rather than routing it to the tower. During a severe strike (greater than 50/kA) to the rod, the present configuration would likely side flash to the generator/nacelle housing before reaching the tower.

## 7 Protection Recommendations

The literature cited and reviewed in Section 4 has much more information on how to tailor a wind turbine lightning protection system than could be presented in this document. However, there are some recommendations and items to consider for specific areas, and, while they repeat some information already presented, I felt it important to put these considerations together in the following sections.

### 7.1 Turbine Buyer Considerations

It is incumbent upon the turbine buyer to demand lightning protection to Class 1 of IEC 61024<sup>10</sup> from candidate vendors. When purchasing a turbine, the smart shopper should, especially for high-risk sites, insist on good lightning protection in the following forms:

- An explanation of how the manufacturer meets IEC 61024 lightning protection
- Blade lightning strike-down conductors with receptors as close as possible to both sides of the tip
- More than one receptor if necessary for turbine blades over 25 m (82 ft) in length
- Fiber optic to uncouple base to tower-top control communication
- Multiple-level surge protection or fiber-optic links for site-wide communication systems
- Good protection from turbine vendor
- Good bonding and shielding of all control/sensor cabling
- Good surge protection and ground reference between the generator, transformer, and power collection system
- Good safety protection for operators and site personnel.

### 7.2 Site Design Considerations

These are concerns specific to wind farm site design that may not be in a turbine manufacturers specification.

#### 7.2.1 *General Site Issues*

- Know your site; assess lightning risk using the National Lightning Detection Network or historical data.
- See IEC 61662<sup>11</sup>, IEC 61400-24<sup>7</sup>, and Dodd et al.<sup>13</sup> for risk assessment methods.
- Use local utility expertise in lightning protection, but don't go overboard on the grounding (tell them it is not a substation).
- Consider sacrificial towers. These are towers with sufficient height to provide protection to a field of turbines. They would take the strike instead of the turbine. The behavior of very tall structures in discharging atmospheric potential is not perfectly understood, but there is certainly a great deal of literature on the subject. Meteorological towers could be used for this purpose, for instance, if located properly.

#### 7.2.2 *Grounding*

- Good earth and turbine grounding is important, see IEC 61400-24<sup>7</sup>.
- Ground electrodes should be designed to a ring or multiple horizontal electrodes.
- Connect foundation reinforcement steel to turbine ground electrodes.
- It is unnecessary to link turbine ground electrodes with bare conductor between turbines (see Cotton et al<sup>16</sup>).

### **7.2.3 High-Voltage Distribution System**

The high-voltage distribution system that connects the turbine to the rest of the local and larger-scale grid is vulnerable to surges coming in on the line, especially if the lines are overhead. The many miles of local distribution overhead lines are quite susceptible to lightning strikes because they are ubiquitous and dominant in the local landscape. In high lightning-risk areas, these distribution lines can collect quite a few direct strikes and the affects of indirect strikes. It is suggested that these lines be underground to minimize this risk.

## **7.3 Turbine Design Considerations**

### **7.3.1 Rotor**

Put conductors in the blade with good receptors in the tip. Terminate these at the first metal piece in the blade (that is contiguous with the hub) as you move inboard. Make conductors short and direct with no loops.

### **7.3.2 Shielding**

Use zone-type protection and thorough shielding, including three-sided metal wireways (minimum) in the nacelle and outside a control cabinet. It is important that all shields be terminated immediately on entry to a metal box or cabinet – it should be considered an extension of the shield. See IEC 61312<sup>12</sup> and DEFU<sup>8</sup> for further shielding discussion.

### **7.3.3 Surge Protection**

A turbine needs good surge protection, especially at locations where wiring transitions into and out of sensors, junction boxes, and control cabinets. Fiber optics are ideal in lightning protection because such material, by its nature, will not carry lightning currents (as long as there is no metallic sheath). I highly advise its use in communication systems, serial connections between subcontrollers, or in-site SCADA systems. Where this is not practical (e.g., sensors), multiple levels of surge protection should be used in concert with good shielding methods. See Dodd et al.<sup>13</sup> for specific information.

### **7.3.4 Bearings and Gears**

There is little evidence that pitch bearings and main shaft bearings can be protected with a bypass circuit because they are near stationary due to their speed of rotation. There is also little evidence that they take much damage from conducting strike currents in large turbines. Garbagnati et al.<sup>17</sup> determined that little or no current is conducted through the gears (except perhaps yaw drives).

## **7.4 Turbine Installation Considerations**

It is important that the systems involved in a wind power plant (SCADA, high-voltage distribution, blades, turbine, etc.) can have their own independent lightning protection systems, which may be rendered useless if they are not integrated properly. The grounding and bonding system is the best place to integrate these, but it can require some thought in advance of construction. See IEC 61400-24 for additional information.

## **7.5 Personnel Safety Considerations**

In very exposed high-risk areas, operator and visitor safety is of the utmost importance. Even moderate-risk areas are of concern because wind turbines are basically big lightning rods installed on exposed ridge tops. Personnel safety can be enhanced with a few simple suggestions:

- In very exposed sites, where possible, provide high-protection locations that personnel can be safely directed to during storms (in a well-grounded/protected shed or metal building).
- Make sure that training standard operating procedures (SOPs) indicate what to do during a lightning storm. Look up the National Lightning Safety Institute (NLSI) on the Web for suggestions.
- Personnel safety is of utmost importance and can be enhanced through early warning systems of incoming storms (see McNiff<sup>2,4</sup>).
- See IEC 61400-24 for safety issues specific to wind turbines.

## 8 Bibliography

1. Muljadi, E.; McNiff, B. "National Renewable Energy Laboratory Program on Lightning Risk and Wind Turbine Generator Protection." *WindPower 97 Proceedings; June 1997, Austin, TX*. NREL/CP-440-23159. Washington, DC: American Wind Energy Association, 1997.
2. McNiff, B.; LaWhite, N.; Muljadi, E. "Characterizing Wind Turbine System Response to Lightning Activity." *WindPower 98 Proceedings; April 1998, Bakersfield, CA*. NREL/CP-500-24790. Washington, DC: American Wind Energy Association, 1998.
3. McNiff, B.; LaWhite, N.; Muljadi, E. "Wind Turbine System Response to Lightning Activity: Preliminary Results." *American Institute of Astronautics and Aeronautics 1998 Proceedings; January 1998, Reno, NV*. AIAA-98-0039. Reston, VA: American Institute of Astronautics and Aeronautics, 1998.
4. McNiff, B.; Muljadi, E. "NREL Wind Turbine Lightning Protection Project Summary." *WindPower 99 Proceedings; June 1999 Burlington, VT*. Washington, DC: American Wind Energy Association, 1999.
5. McNiff, B.; Muljadi, E. "NREL Wind Turbine Lightning Protection Activities." *EWECE 1999 Proceedings; March 1999, Nice, France*. Brussels, Belgium: European Wind Energy Association, 1999.
6. McCoy, T., et al. "Lightning Activity in the DOE/ EPRI Turbine Verification Program." *WindPower 2000 Proceedings; May 2000, Palm Springs, CA*. Washington, DC: American Wind Energy Association, 2000.
7. IEC. *Wind Turbine Generator Systems, Part 24: Lightning Protection*. IEC 61400-24 CDV. Geneva: International Electrotechnical Commission, 2000.
8. DEFU. Recommendation No. 25, *Lightning Protection of Wind Turbines*. Lyngby, Denmark: Research Institute for Danish Electric Utilities, 1999.
9. NFPA. *Standard for the Installation of Lightning Protection Systems*, NFPA 780. Quincy, MA: National Fire Protection Association, 1995.
10. IEC. *Protection of Structures Against Lightning*, IEC 61024. Geneva: International Electrotechnical Commission, 1998.
11. IEC. *The Assessment of Risk Due to Lightning*, IEC 61662. Geneva: International Electrotechnical Commission, 1996.



12. IEC. *Protection Against Lightning Electromagnetic Impulses*, IEC 61312, Parts 1-5. Geneva: International Electrotechnical Commission, 1999.
13. Dodd, C.W.; McCalla, T. Jr; Smith, J.G. *How to Protect a Wind Turbine from Lightning*. NASA CR-168229. Cleveland, OH: National Aeronautics and Space Administration, September 1983.
14. Dodd, C.W.; McCalla, T.M. Jr.; Smith, J.G. "Design Considerations for Lightning Protection of Wind Turbines." *Sixth Biennial Wind Energy Conference and Workshop*. Boulder, CO: American Solar Energy Society, 1983, pp. 687-695.
15. Gewehr, H.W. "Lightning Protection for Composite Rotor Blades." *Conference Proceeding of the American Wind Energy Association, June 1980, Pittsburgh, PA*. Washington, DC: American Wind Energy Association, 1980.
16. Cotton, I., et al. *Lightning Protection of Wind Turbines - A Designers Guide to Best Practices*. Manchester, UK: UMIST, 1999.
17. IEA. "Lightning Protection of Wind Turbine Generator Systems and EMC Problems in the Associated Control Systems." *Annex XI, 26th Meeting of Experts; Milano, Italy, March 1994*. Paris, France: International Energy Agency, Annex XI, 1994.
18. ANSI/ IEEE. *Guide for Safety in AC Substation Grounding*, ANSI/ IEEE Std 80 – 1986. New York: American National Standards Institute, 2000.
19. IEA. *Recommended Practices for Wind Turbine Testing and Evaluation- 9. Lightning Protection for Wind Turbine Installations*. Paris, France: International Energy Agency, Annex XI, 1997.
20. Fisher, F.A.; Plumer, J.A. *Lightning Protection of AircraFort Pittsfield, MA*: Lightning Technologies Inc., 1990.
21. Golde, R.H., et al. *Lightning, Volume 1- the Physics of Lightning*. San Diego, CA: Academic Press, 1977
22. Uman, M.A. *The Lightning Discharge*. San Diego, CA: Academic Press, 1987.
23. ANSI/ IEEE. *Recommended Practice for Grounding of Industrial and Commercial Power Systems*, IEEE Std 142- 1980, ISBN 0-471-89573-3. New York: American National Standards Institute, 1980

# **Appendix A - Wind Turbine Lightning Protection Project: Field Test Plan**

## **A.1 Purpose of Test**

The purpose of this effort is to evaluate the lightning protection on components of a wind turbine generator, the entire wind turbine generator system, and the wind farm at a particular site. Initially, a survey of the protection system will be carried out. A number of techniques and methods will be used to evaluate the effectiveness of this protection in mitigating damage from lightning strikes. Finally, some advanced-warning, lightning-detection systems will be exercised and evaluated for high-risk sites.

## **A.2 Approach and Planning**

To achieve the goals, a combination of remote sensing and local measurement will be carried out on the Central and South West (CSW) Services site near Fort Davis, Texas. The questions posed are as follows:

- Are the standard lightning protection schemes sufficient?
- What are the highest priority protection targets?
- What are the most effective methods to protect electrical and mechanical components of a wind turbine?
- How can operator safety be maximized?
- What is the most effective way to include lightning risk evaluation in a standard site monitoring process?

### **A.2.1 Approach**

The highest-risk items in the wind turbine system appears to be the control, communication, and electrical systems. It has also been noted that proper earth ground is the most important deterrent to lightning damage. It is a well-accepted notion that the best way to deal with lightning is to tolerate lightning strikes onto the structure in such a way as to provide low-resistance, low-risk pathways to earth ground.

We will be monitoring wind turbines in the field in a high lightning-risk area to ascertain the effectiveness of standard, site-specific, and special lightning protection schemes.

### **A.2.2 Test Phases**

Because of the multivariate goals, the tests will be conducted in multiple, overlapping phases. These phases are discussed below.

#### **A.2.2.1 Survey of Existing Lightning Protection**

It is necessary to know the existing lightning protection system, so that the weakest link can be predicted. For the sites being analyzed, we will survey the standard system and document any changes made specifically for the test, or in response to lightning damage. The following steps will be taken:

1. Draw the electrical diagram of the power circuit from the generator to the transformer/substation interfacing with the utility.

2. Draw the electrical diagram of the signal circuit for the wind turbine generator (WTG) control and data acquisition.
3. Draw the possible lightning paths from the potential lightning attachments (blade, nacelle, tower, etc.) to ground.
4. Measure the ground resistance at the site.
5. Draw the grounding system of the entire wind farm.

Such documentation will be useful in evaluating safety system effectiveness, or corrections, in the event of a lightning incident.

#### *A.2.2.2 Lightning Protection Effectiveness*

The effectiveness of WTG subsystem protection methods will be evaluated using an array of lightning current counters, cameras, and operator damage reports. The locations of interest include:

- Brushes/slip rings to allow lightning currents to bypass main and yaw bearings
- Uptower generator protection
- Downtower control system or communication system protection
- Air terminals (lightning rods)
- Droop grounding cable (instead of using tower and yaw bearings as path)
- Blade protection methods.

All of the turbines in the CSW wind plant will be instrumented with current measuring and stroke counting devices to track the lightning path to ground. It is expected that, as a minimum, we will detect lightning current at:

- The grounding strap (or on tower leg) from the structure to earth-ground
- The grounding strap between the control system and earth-ground
- Possibly, the ground fault detection to the utility mains.

From these items we can detect whether a stroke was conducted down the tower, into the control system, or into (or from) the utility mains.

Any suspected lightning damage observed on the turbine will be logged with specially developed field service report sheets to be supplied to maintenance personnel. Training will be provided to maintain observation and reporting consistency.

By keeping track of attendant damage and collecting this data with a time-stamp, we can track the effectiveness of various damage avoidance steps. For very damaging storms, we can petition the National Lightning Detection Network (Global Atmospherics) for specific information on the exact time, location, and amplitude of strikes during that storm in our test area. This can be used to correlate cause and effect.

A video camera will be used to resolve lightning strikes to the WTG structures. Other researchers have indicated (and provided reasonable pictures to back this up) that there is enough resolution in video cameras to identify lightning strikes to specific transmission line poles, as well as locate flashovers across specific line insulators, from a mile away. An advance-warning lightning detection system will be used to turn the camera on and off to allow taping only during the lightning storm events.

#### *A.2.2.3 Advanced Warning of Lightning Activity*

It is important to improve the operator safety at the wind turbine site during lightning season. Sufficient advance notice of incoming electrical storms can provide the difference between life and death for maintenance and operations personnel. In light of this, we will be using and evaluating devices that

provide advance notice of lightning activity. It should be noted that much of this evaluation will be qualitative.

A personal device called the SkyScan (\$150 plus chargers, etc.) can be worn by service personnel or installed in the service vehicles. The range of these devices is claimed to be up to 40 miles (1 to 2 hour warning for even fast storms). We will have the site operation personnel use two of these devices and have them report on their effectiveness.

A commercially available PC hardware and software package called Stormtracker is available to track incoming electrical storms (\$500 inclusive). The range of this device is claimed to be up to 100 miles. We will have the site-monitoring computer equipped with this package to allow office personnel to alert the in-field operators. The effectiveness of this will also be tracked.

Another device (LSU-1) can be used directly with our data acquisition system or the meteorological system. It uses a low-cost antenna/signal conditioning package (\$50) that could be mounted on the meteorological tower or a wind turbine to achieve a range of over 200 miles for advance warning. The output is variable with distance from the lightning activity. The LSU-1 could power a meter or activate a simple alarm at the site. Certainly the data can be collected by the data acquisition system to directly measure its effectiveness.

#### ***A.2.2.4 Site Lightning-Risk Evaluation***

This phase will be used to assess the effectiveness of the NLDN and various other options for determining lightning risk. It is also possible that some of the advance-warning devices can be included in the meteorological system during the initial site assessment program. In this case, the lightning risk may be evaluated along with the wind resource.

### **A.3 Participants**

In order to facilitate the rapid implementation of this project, other consultants will be brought in. These groups will be managed by McNiff Light Industry, but their billing will be directly to the National Renewable Energy Laboratory (NREL). The planning of the process will be a joint effort by all participants. The following is a discussion of the tasks to be performed by these various groups.

#### ***A.3.1 McNiff Light Industry - Brian McNiff and Niels LaWhite***

Mr. McNiff will oversee the whole project under the supervision of Ed Muljadi at NREL. Supervision of the project participants, budgeting, scheduling, and all aspects of testing will be McNiff's major chores. Mr. LaWhite will develop all electronic and fiber-optic circuits and assist in the site installation. McNiff will also assemble the final report and present the results to the various stakeholders.

#### ***A.3.2 TVP and Other Stakeholders***

The stakeholders will be copied on the draft test plan as it is matured to the final item. Also, they will be included in periodic reporting and the final results presentation. The participating entities in the Department of Energy (DOE)/Electric Power Research Institute (EPRI) Turbine Development Program (TVP) are the chief stakeholders in this project. These include:

- NREL - Ed Muljadi, Brian Smith, and Sandy Butterfield
- EPRI - Chuck McGowin and Ed Demeo
- Zond Energy Systems - Kevin Cousineau
- Central and Southwest Services - David McNabb
- Green Mountain Power - John Zimmerman and John Saintcross
- LG&E - Jeff Holbrook

- Other TVP participants

Because of the major DOE involvement, the greater wind power industry and research community will be kept abreast of developments and results.

### **A.3.3 CSW Wind Power Plant - Brian Champion and Ben Givens**

It is expected that CSW will provide the use of turbines, site personnel to support the testing, and access to the site. It is expected that the site personnel will be supported by CSW.

### **A.3.4 Global Atmosphericics**

This group runs the NLDN. They have the ability to provide historical facility site analysis (FSA) (lightning activity distribution for the last eight years at the Texas sites) as well as detection and forewarning services. Our test will initially use their FSA reports as the basis for our short-term tests. If significant damage is experienced, we can ask Global Atmosphericics to identify the exact strokes (if we can clock the event time) that caused the damage. The strokes can be characterized as to intensity and type using their FaultFinder service. This information will be invaluable, since their level of reliability and accuracy (95% or better) is quite high.

### **A.3.5 Dr. Andy Plumer, Lightning Technologies, Inc. -- Lightning Consultants**

Dr. Plummer's expertise is in the protection of structures and aircraft against lightning damage. He will be an advisor to the test development, data analysis, and recommendations regarding the current state of the art of protection systems for structures such as wind turbines.

### **A.3.6 Lightning Technologies, Inc. -- High-Voltage Laboratory**

Lightning Technologies (LTI) has a fully staffed commercial high-voltage laboratory that we will use to tune and "road test" our sensors and data collection system before installing them in the field.

## **A.4 Testing**

The following is a description of the anticipated test equipment and the process envisioned to meet the test objectives.

### **A.4.1 Instrumentation**

The data acquisition system will be used to collect lightning strike data from current transformers and inductive shunts. These devices will be configured to maintain isolation from the actual lightning current path. Simple dataloggers will collect the sensor information at each turbine. A central '486 PC will be used to operate the test system and collect the data from the loggers.

#### **A.4.1.1 Field-Test Overview**

A data acquisition system will be set up to detect and log lightning strikes to all 12 of the Zond turbines at the CSW site near Fort Davis, Texas. Ideally, for all lightning hits, we would like to determine the following:

1. An event time-stamp (15 second accuracy should suffice)
2. Peak current and other waveform details (how much available energy)
3. Where on the structure it hit and what path it took to earth
4. Any resultant damage to the structure, control system, or wind farm equipment.

Time-stamp is important to align the data collection to the NLDN database. The NLDN collects peak currents on all strikes in the United States with a claimed location resolution of 500 m (1,640 ft), a time resolution in the tenths of seconds range, current estimation in the 85% range, and an overall reliability

(event detection) of 95%. All this means that if we get a flurry of hits on wind turbines and we know exactly when and where (the turbines are fixed in space, we will use a GPS to locate them), we can get a report from NLDN for \$250 (post facto) that will identify these strikes.

#### A.4.1.2 Sensors

Three lightning-current sensing units will be installed at each turbine to measure the lightning current with a modified ferrite core torroidal transformer or an inductive shunt (see Figure A-1). One current sensor will be placed on the grounding strap between the tower base and the earth grid. Ideally, more sensors would be installed to further identify the general strike location (i.e., the rotor/hub, nacelle, or tower) and its path to ground (e.g., through the controller protection, etc.).

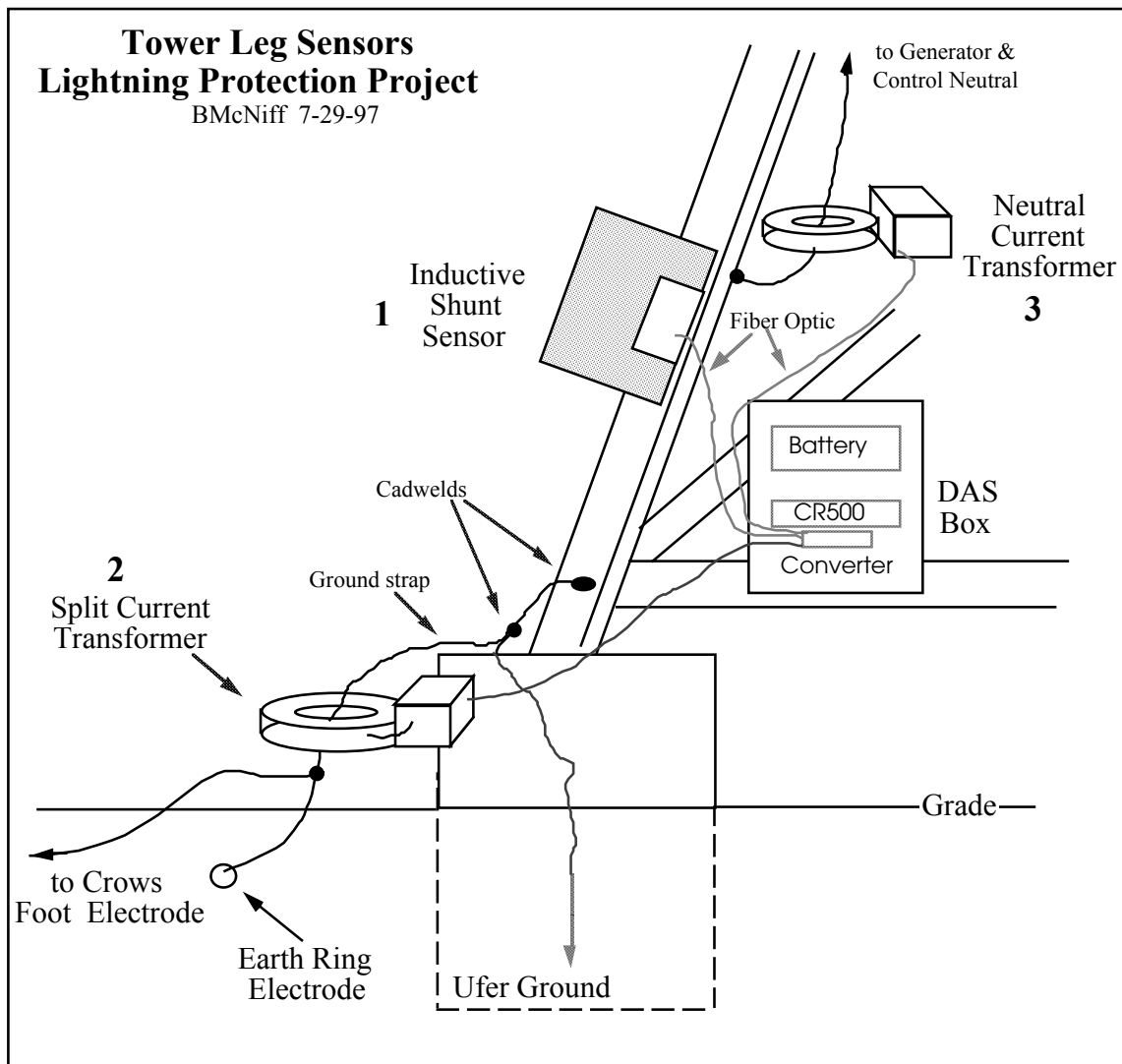

**Figure A-1. Test sensor locations**

The inductive shunt will be mounted on a tower leg (see Figure A-1) measuring the voltage drop along a 1.8-m (6-ft) length of tower leg (consistent section), thereby implying stroke current rate of rise in that leg. Associated electronics will condition the signal to provide low-level proportional voltage. Triggering on the detection of a large lightning-induced spike, the electronics will provide a pulse on a

fiber-optic pathway to be counted by the datalogger. This information can later be used to deduce the approximate magnitude and envelope of the strike via the NLDN.

In a similar application, a Rogowski coil and/or a modified ferrite core current transformer will be used to transform lightning currents in the ground straps (at the tower, in the controller, and at the substation) to a useable low-level current waveform. This waveform will be conditioned similarly to the inductive shunt output to provide a pulse on a fiber optic pathway to be counted by the datalogger.

Although peak lightning currents can exceed 200 kA, we expect that current levels in the range of 1,000 A or less may actually be available for detection at the ground straps because of the competing grounding pathways (Ufer foundation grounds, ground straps at other three legs, etc.). We also expect that the leg-mounted inductive shunt will only be exposed to about 15% of the stroke current because of the multiple paths for current in the 4-leg truss tower.

#### ***A.4.1.3 Data Acquisition System***

The PC-based data acquisition system (DAS) will use an array of Campbell Scientific CR500 dataloggers. Loggers at each of the 12 turbines and at the substation (point of common coupling) will operate autonomously to collect data (see Figure A-2). This is to avoid the (strong) possibility of the DAS serial line acting as a lightning current conductor. It is the experience of Zond, CSW, Kennetech, and others that the communication lines and circuits are usually the first victims of direct and indirect lightning effects in wind farms.

All sensors will have their electronic circuits enclosed in grounded metal boxes with a shielded sensor wire bringing the signal in and a fiber optic line carrying the output to the logger. The output will be an LED signal of a length proportional to the sensed peak current or voltage (from inductive sensor). The loggers will also be enclosed in metal boxes, and they will be powered by battery and isolated power supplies to reduce susceptibility to indirect or direct lightning current effects. A small signal front end (photodiode and associated electronics) will use the LED pulse from the sensor to open an OR gate to a pulse train that will be sensed by the CR500 counter channel.

When each event is sensed at the CR500's counter channel, the sensor ID and pulse counts will be logged to non-volatile memory and time stamped from an internal clock source. The resulting amount of counts will be converted back to peak current or rate of rise ( $di/dt$ ) in post processing, and the time stamp will be used to match to maintenance reports and NLDN interrogation.

#### ***A.4.1.4 Data Collection***

The event log will later be uploaded to the DAS PC manually by the CSW site operator. The minimum upload period will be once a week, or just after a particularly severe storm. The logger will hold about 500 strikes of data and the battery should last a couple of months. The upload can be done simply with a laptop computer during regular site checks or meter readings. The process, including computer setup and breakdown, and documentation, requires about 10 minutes per unit.

#### ***A.4.2 Test Set-up***

It is conceivable that we may not get any direct lightning strikes to wind turbines during the monitoring period. It will be unlikely that we will actually be on-site and collecting data when a storm comes through. Although, if we are, we want to make sure that the sensors, instrumentation, and circuitry will behave as planned.

#### *A.4.2.1 High-Voltage Laboratory Test*

We will install a complete array of sensors and instrumentation on a tower mock-up in the high-voltage laboratory at Lightning Technologies in Pittsfield, Massachusetts. Our intention is to completely exercise the sensors and data collection system in a controlled lightning environment before installing them in the field in Texas.

A complete setup, including a mock-up of a tower leg and a turbine control box, will be wired up with all three types of sensors wired to a CR500 datalogger. The datalogger will be configured, connected to the sensors, and communicating to the network computer just as intended in the field. Sensor operation, circuit set points, and DAS protection will be tuned and tested in the simulated lightning environment available in the high-voltage laboratory. It is expected that 10 to 12 lightning discharges can be forced into the mock-up during the one-day test.

McNiff and LaWhite will acquire and assemble two of each sensor and associated instrumentation, including:

- Two CR500 dataloggers with aluminum boxes, 12-V battery, and 5-sensor fiber-optic receiver circuits
- Two sets of fiber-optic serial interface circuits for CR500
- The site computer with control software and optic serial interface
- Two inductive shunt sensors with fiber-optic transmitter circuits
- Two standard current transformers with comparator and optic transmitter circuits
- One 1000 A Rogowsky coil with comparator and fiber-optic transmitter circuits
- Some ear plugs

It has also been suggested to connect one of these systems to a Second Wind site monitoring system to determine if the popular wind farm monitoring system could be modified to provide lightning strike sensing. If so, this could inexpensively augment the program's plans for expanding the lightning safety database. We will investigate including this option in the high-voltage laboratory tests as time permits.

#### *A.4.2.2 Advanced Preparations for CSW Field Test*

The completed test plan will include sensor and signal-conditioning designs and instrumentation modifications (from off-the-shelf configuration). These will be modified with intelligence from the LTI (and maybe Fort Blanding) tests. These devices will then be fabricated by McNiff Light Industry (MLI) or farmed out to a vendor and tested for quality.

The CSW site plans will be investigated for the ability to run the fiber-optic link from all turbines to the operations building. Use of existing conduit is expected because fiber optic is of low profile and not disturbed by proximity to high-voltage lines.

The camera and video recording systems will be set up and their operation reviewed before installation in the field, if possible. An additional VCR will be purchased for video data analysis at the MLI office. Also, a frame-capture computer package will be purchased and tested.

#### *A.4.2.3 In-field Setup*

The CSW site is laid out in two ridge-based clusters of turbines spaced about 90 m (300 ft) on center. One cluster includes 7 units (6 through 12), where unit 7 is about 152 m (500 ft) from the operations and maintenance (O&M) building. The second cluster includes 5 units (1 through 5), and the closest is unit 5 at 396 m (1,300 ft) from the O&M building.



It is expected that the DAS computer will be in the O&M building along with the VCRs. The two cameras will be atop the building protected by a lightning rod (air terminal). An uninterruptible power supply will be sized to allow camera and recorder operation for one hour after loss of utility power. This should allow for completion of any recording of lightning activity that may have caused the outage.

Initially, sensors and instrumentation will be installed on two of the higher-risk turbines (most frequently struck or damaged) on the site. Then the CR500 units will be put into autonomous operation. The second items installed will be the cameras and video recording systems. These two steps will allow us to collect some early, observable data while on site. If we are lucky enough to capture data from lightning strikes, we can manually download data or milk it directly with a laptop PC.

The camera-trigger circuit will be monitored temporarily with an extra datalogger to attempt to tune the circuit while on site. Hopefully, passing storms will be monitored for the response in the trigger circuits (we could measure the analog values of the sense circuits). The set points can be adjusted if we get one or two storms while on site. Also, any focus, zoom, or light-level adjustments can be made to the cameras if we get both a day and night storm while on site.

The remaining turbines will be instrumented along with the substation. The fiber-optic line will be run to connect all the devices to the central computer. The response of each sensor will be checked while connected end-to-end to the operating instrumentation network.

The system will be exercised as thoroughly as possible before leaving it in automated operation. NREL will be asked to call into the site to perform a remote download and control (if we are allowed use of a telephone line) while we are on site.

#### *A.4.2.4 Power Quality Monitoring*

A power quality monitor supplied by NREL will be installed at either the substation or in the O&M building to log surges, droops, brownouts, and system outages. This information will be cataloged and consulted as needed to associate damage and stroke information.

#### *A.4.2.5 Lightning Storm Warning Systems*

Three lightning storm warning systems will be installed. An American Weather Enterprises device will be installed in the field computer wired to its remote sensor. The software will be exercised by the CSW site operator and evaluated in advance of storms. His comments will be included in the reports and recommendations.

A similar review of the Skyscan devices will be asked of field personnel. These units are portable and about the size of a large handheld calculator. It can be installed in an operator vehicle or worn on the belt when up on a turbine. An array of warning beeps and flashing lights warn the operator of incoming storms. These warnings progress in intensity the closer the storm is to the operator. These will be provided to site personnel for the duration of the test.

A remote lightning detection antenna (responding to broad spectrum discharge) will be installed at the highest available point to trigger a warning device or input into one of the CR500 analog channels. Its low price tag could be very attractive if it proves anywhere close to reliable. Site personnel will also monitor its response.

### **A.4.3 TEST PROCESS**

#### ***A.4.3.1 High-Voltage Laboratory Test***

A test plan will be generated specific to this test including the anticipated goals and procedures. McNiff will attend a lightning safety course at the same facility in mid-May, one month before to the laboratory test. He will use some of this period to work out the test requirements and details. MLI will generate a report specific to this test that will include the lessons learned and modifications instituted as a result of the test.

#### ***A.4.3.2 Field Test***

Because the nature of the test is to document and track the affect of rather elusive stochastic events, continuous monitoring will be performed.

The CSW site operator will collect data during the testing process. Although the data collection program is mostly automated, the operator will be responsible for the following:

- Monitoring video recording system, changing tapes as needed
- Downloading data into storage archive
- Checking dataloggers and maintaining as instructed by MLI
- Maintaining documentation and test log
- Sending data, documentation copies, and video tapes to MLI
- Documenting damage from lightning and log lightning storms.

The damage observed will be logged with specially developed field service report sheets to be supplied to maintenance personnel. Training will be provided to maintain observation and reporting consistency.

In the event of failure of the fiber optic serial link, the site operator may have to individually milk each of the data loggers once every week (the logger will hold about 500 strikes of data and the battery should last a couple of months). It can be done simply with a laptop computer during regular site checks or meter readings. The process, including computer setup and breakdown, requires about 10 minutes per unit.

#### ***A.4.3.3 Documentation***

Two copies of the documentation will be kept for redundancy. These will be at MLI and on the CSW site. The complete test system wiring diagram will be provided and maintained with the documentation to assist in troubleshooting as necessary.

#### ***A.4.3.4 Data Quality Assurance***

McNiff will maintain documentation and procedures to demonstrate proper error analysis and repeatable quality assurance. Standard test procedures will be maintained throughout the process.

### **A.4.4 Site Wiring and Protection Survey**

Because the nature of the test is to document and track the effect of as unpredictable a phenomenon as lightning, a complete survey of the wind park and wind turbine specific wiring diagram will be carried out. The following items will be documented and mapped:

- On-line, high-voltage circuit, including surge protection
- Grounding diagram for the wind turbine
- Grounding rod, earth/ground grid, and grounding treatment for the wind park

- Nature of connection of ground system to rebar and concrete foundation
- Shielding and surge protection of sensor and communication system
- DAS system protection and wiring pathways
- SCADA system protection and wiring pathways.

This information will be useful in determining the cause and prevention of damage detected in the test. Also, as the base of lightning damage data expands, this information will be useful to properly compare causes of lightning damage across a range of sites.

## **A.5 Data Analysis**

A data analysis plan will be developed as a subset of the test plan. Statistical trends of data will be the primary focus. Analysis will be performed by McNiff and presented in monthly reports.

All of the turbines in the CSW wind plant will be instrumented with surge and stroke-counting devices to track the lightning path to ground. It is expected that, as a minimum, we will detect lightning current at

- The grounding strap (or on tower leg) from the structure to earth-ground
- The grounding strap between the control system and earth-ground
- The ground fault detection to the utility mains.

From these items we can detect whether a stroke was conducted down the tower, into the control system, or into (or from) the utility mains. Video records of lightning strikes may shed some light on the location of specific strikes.

Any suspected lightning damage observed on the turbine will be logged with special field service report sheets to be supplied to maintenance personnel. Training will be provided to maintain observation and reporting consistency.

By keeping track of attendant damage, and collecting this data with a time-stamp, we can track the effectiveness of various damage-avoidance steps. For very damaging storms, we can petition the NLDN (Global Atmospherics) for specific information on the exact time, location, and amplitude of strikes during that storm in our test area. This can be used to correlate cause and effect.

It is difficult to predict the amount and quality of data that will be collected and processed. However, stroke data will be collected consistently, and the affect of damage on maintenance will be documented. Even with a small amount of data and some simple statistical projections (based on NLDN larger time period data), a great deal could be discovered to improve the overall protection of WTGs in a high lightning-risk environment.

## **A.6 FINAL REPORT**

Monthly progress reports will be developed and presented to NREL by MLI once the testing is underway.

On-going progress and the results of the effort will be presented at both a special presentation at NREL (or a regular TVP meeting) and at an annual wind industry conference.

A final report will be issued to provide assistance to the wind industry in using the proper lightning safety techniques for wind turbine installations.

### Camera Control (atop O&M Bldg)

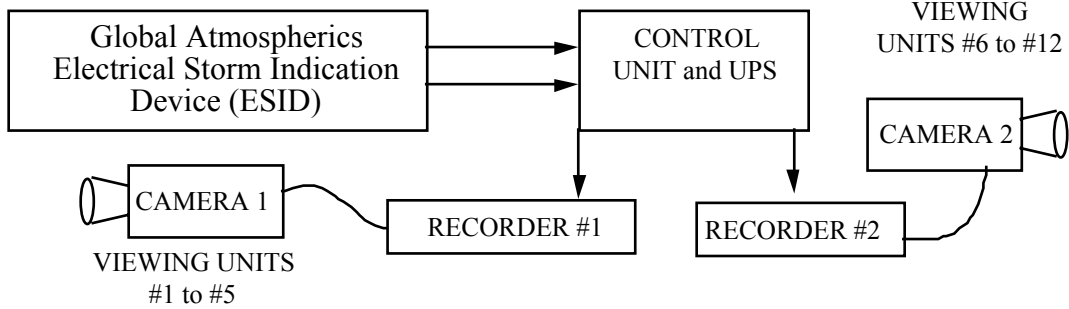

### Turbine #1, Typical Sensor Arrangement

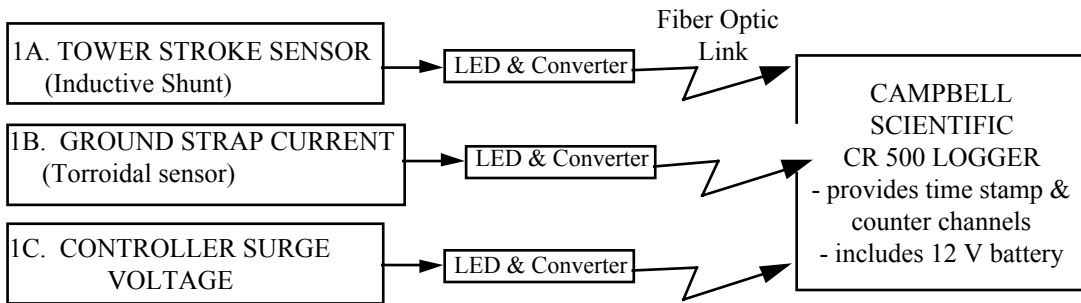

• • • REPEATED FOR TURBINES #2 to #12

### Site Switchgear - Point of Common Coupling

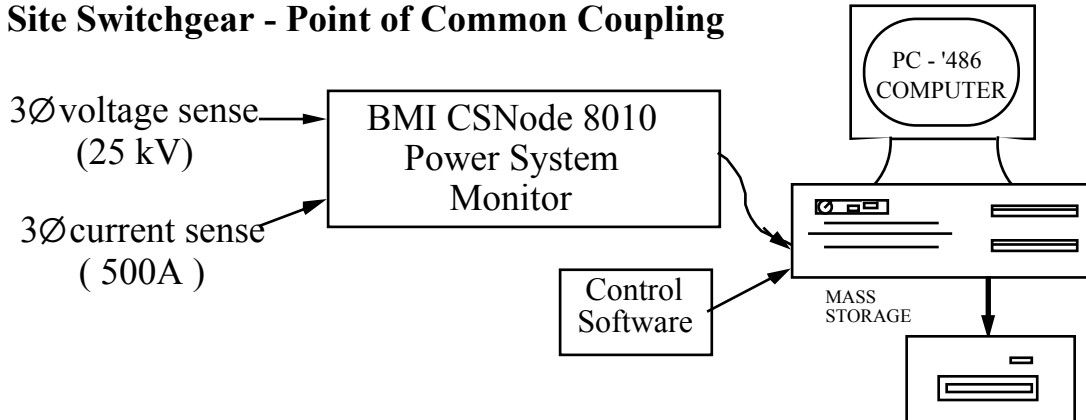

Figure A-2. Instrumentation description for CSW field test



## **Appendix B - Plan for Test of Strike Sensor in a High-Voltage Laboratory**

A test was carried out at a high-voltage laboratory operated by Lightning Technologies, Inc. (LTI). Several sensors and a data acquisition system were evaluated for its ability to sense lightning strikes on a wind turbine tower in a high-voltage field environment. A trip to LTI was made by Brian McNiff and Niels LaWhite of McNiff Light Industry (MLI).

Travel was begun on 8 June 1997 and completed on 10 June. The high-voltage laboratory was rented out for the 9th of June. The test plan is described in this appendix.

### **B.1 Test Goals**

The purpose of this effort is to evaluate the effectiveness of instrumentation to be used in the National Renewable Energy Laboratory (NREL) wind turbine (WTG) Lightning Protection Project. In this field test part of the project, lightning currents being conducted through the WTG structure to ground will be detected by custom sensors and registered in a data acquisition system (DAS). A fully configured array of sensors for a complete wind turbine and its attendant DAS will be installed and tested in the high-voltage laboratory. The sensors, if effective, will be tuned and calibrated to the extent possible.

### **B.2 Test Plan**

The following discussion assumes knowledge of the project details as outlined in the overall test plan, version 3.0. Appendix A includes a description of the field test approach and instrumentation from this plan.

We will install a complete array of sensors and instrumentation on a tower mock-up in the high-voltage laboratory at [Lightning Technologies](#) in Pittsfield, Massachusetts. Our intention is to completely exercise the sensors and data collection system in a controlled lightning environment before installing them in the field in Texas.

A complete setup, including a mock-up of a tower leg and a turbine control box, will be wired up with all three types of sensors connected to a CR500 datalogger. The datalogger will be configured, connected to the sensors, and log data identically as intended in the field. Sensor operation, circuit set points, and DAS protection will be tuned and tested in the simulated lightning environment available in the high-voltage laboratory.

A 1.5-MV generator will be used to discharge simulated lightning current through the test rig at up to 2,000 amps. It is expected that 10 to 12 lightning discharges can be forced into the mock-up during the one-day test.

The test results will be used to mature the sensors and custom electronics design. Also, the collected data will be calibrated to the known current and voltage waveform experienced in the lab. These results will be used to scale up to interpret the sensor response during actual in-field lightning strikes.

### **B.2.1 Tower Mock-up**

The Z40A wind turbine tower is a four-sided truss of angle steel construction. The general arrangement of the truss is shown in Figure A-1. The inductive sensor (1, in Figure A-1) will be between webbing junctions. The main leg is 20.3 x 20.3 x 2.2 cm (8 x 8 x 0.875 in.) ASTM-572 galvanized structural steel [section area is 85.1 cm<sup>2</sup> (13.2 in.<sup>2</sup>)]. The webbing is 8.9 x 8.9 x 1.3 cm (3.5 x 3.5 x 0.5 in.) ASTM A-36 galvanized structural steel [section area is 21 cm<sup>2</sup> (3.25 in.<sup>2</sup>)]. Based purely on section area, it is estimated that the main leg will experience about 25% of the total current.

All four of the tower legs are attached to the grounding grid by ground strap and to Ufer grounds in the concrete foundations. As a result, the actual current in the ground strap is difficult to predict.

A piece of steel equal in section to the main leg will be the test lab mock-up. It will be propped up into a near vertical position with a ground strap similar to that on the actual tower as a return conduction path. Two clamps or bolts will be installed on this piece of steel as taps for potential difference sensing. Care will be taken to keep the sensor wires from being inductive loops. An alternate sensor will use an inductive loop or transformer effect.

### **B.2.2 Sensors**

The inductive sensor on the leg mock-up will respond to the di/dt of the current. We anticipate using the measured waveforms to evaluate our estimates of inductance and voltage response. Two different types of sense electronics will be used for evaluation purposes. Replacements for both types will be available in the event of damage.

Two different current transformers and a Pearson Rigouski coil will measure the current in the ground strap. It is expected that LTI will provide the latter for their own waveform sensing.

### **B.2.3 Expected Signal Levels**

We assume that the main leg takes 25% of the strike current. The minimum current that the leg experiences is probably over 1 kA (full stroke current of 8 kA is exceeded by 97% of all strikes, this is 25% of that). Also, assume that the lightning stroke reaches full current in 2 microseconds (LTI and Uman). The inductance is expected to be 1 μH/m. Assume that the distance between connections is 1 m (3.3 ft).

In this case, the inductance,  $L = 1 \mu\text{H}$ , and the circuit equation,  $V = L (di/dt)$ , should apply. If the current goes from 0 to 1,000 A in 2 μS, then:

$$V = 1 \mu\text{H} (1,000\text{A}/2 \mu\text{S}) = 500\text{V}$$

Thus we would expect a 500 V pulse for 2 μS. There is our basic design parameters for the sense circuit. The upper range should be 30 times this, or 15 kV. Survival should be twice that.

The current in the ground strap in the test will be equal to whatever the level of the zap, because there is only one return path.

### **B.2.4 Data Acquisition System**

McNiff and LaWhite will assemble two of each sensor and associated instrumentation, including:

- Two CR500 dataloggers w/steel boxes, 12 V battery

- Two inductive shunt sensors with fiber-optic transmitter circuits
- Two standard current transformers w/comparator and optic transmitter circuits
- Two, 3-sensor fiber-optic receiver circuits
- One 2000 A Rogowsky coil with comparator and fiber-optic transmitter circuits
- Portable computer with control software and serial interface
- Two inductive shunt sensors with counter circuits.

A program has been developed and tested for the datalogger operation.

### **B.3 Test Process**

#### ***B.3.1 Test Matrix***

The output of the high-voltage generator will be discharged directly into the test rig and returned via a ground strap. A minimum of six strikes will be discharged onto the rig. Additionally, a minimum of three strikes will be made to a nearby structure to determine if induced impulses may confuse the target instrumentation. It is hoped that a range of discharge currents can be used to help calibrate the test items.

#### ***B.3.2 Operation of Test Equipment***

All operation of the LTI lab will be performed and directed by their trained technicians and engineers. MLI will set up the test rig and down load data between discharges. Adjustments to the rig and modifications or repair of the sensors and electronics will be made in response to collected data.

#### ***B.3.3 Data Collection***

LTI will collect waveform data, but it will be the responsibility of MLI to transfer and document it as needed for the test purposes. Data collected from the rig DAS will be performed between discharges.

#### ***B.3.4 Safety***

A briefing of the LTI safety procedures is expected at the onset of testing. LTI laboratory standard operating procedures will be adhered to.

#### ***B.3.5 Data Quality Assurance***

McNiff will maintain documentation and procedures to demonstrate proper error analysis and repeatable quality assurance. Standard test procedures will be maintained throughout the process.

### **B.4 Data Analysis**

A data analysis will consist of matching the DAS output with the LTI measured waveform raw data applicable to the sensed item. It is expected that this will include peak current and the rate of rise of the current. A calibration of the current transformer and inductive circuits will be developed from this data.



## **B.5 Participants**

The following is a list of participants in this part of the project and an outline of their level of participation.

### ***B.5.1 McNiff Light Industry - Brian McNiff and Niels LaWhite***

Mr. McNiff will oversee the project under the supervision of Ed Muljadi at NREL. Supervision of the project participants, budgeting, scheduling, and all aspects of testing will be McNiff's responsibilities. Mr. LaWhite will develop all electronic and fiber-optic circuits. Both McNiff and LaWhite will perform tests at the LTI laboratory. McNiff will also assemble the test report and present the results to NREL.

### ***B.5.2 Dr. Martin Uman - Lightning Consultant***

Dr. Uman's expertise is in the physics and behavior of lightning in the atmosphere and in the structures it affects. He will be an advisor to the test development, data analysis, and recommendations regarding the LTI high-voltage laboratory test.

### ***B.5.3 Lightning Technologies, Inc. - Ed Rupke and staff***

Lightning Technologies has a fully staffed commercial high-voltage laboratory that we will use to tune and "road test" our sensors and data collection system before installing them in the field. LTI staff will operate the high-voltage generator as needed. LTI safety procedures and SOP will be adhered to by MLI.

## **B.6 Laboratory Test Report**

A report will be issued to NREL describing the procedures of the test and what was achieved and learned. Modifications to the test setup will be reflected in a modified field-test plan. New sensor and electronic designs will be instituted immediately for use in the field test.

## Appendix C: Minutes for WTG Protection Planning Meeting

**Secretary:** Brian McNiff, McNiff Light Industry

**Convened** meeting on Jan 10, 1997 at National Wind Technology Center, NREL, Golden, Colorado

### C.1 Agenda

+ Sandy Butterfield gave opening remarks and introduction.

The goal of this meeting is to detail experiences of lightning damage and observations of lightning protection details pertaining to wind turbines. From this discussion, NREL would like to take actions to improve the implementation and understanding of wind turbine lightning protection. What should those actions be? What effort by NREL would be most useful and supportive of the U.S. wind industry?

+Lunch arrangements were discussed.

+ 3:30 p.m. seems to be stopping point for some participant's travel.

### C.2 Attendees:

|                   |  |  |
|-------------------|--|--|
| Sandy Butterfield | NREL                                       | Technical monitor                        |
| Ed Muljadi,       | NREL                                       | Electrical engineer                      |
| Brian McNiff      | McNiff Light Industry                      | Consultant                               |
| Rich Kithill      | National Lightning Safety Institute (NLSI) | Lightning consultant                     |
| Kevin Cousineau   | Zond Energy Systems                        | Electrical/electronics manager at Zond   |
| Chester Kawieki   | Lightning Protection Corp                  | Lightning consultant and vendor to Zond  |
| Dave McNabb       | Central and South West Services (CSWS)     | TVP participant                          |
| Brian Smith       | NREL                                       | TVP project manager                      |
| Dennis Barley     | NREL                                       |  |
| Steve Jones       | Southwestern Public Services (SPS)         | Operator of Carter turbines in Texas     |
| John Saintcross   | Green Mountain Power (GMP)                 | TVP participant                          |
| Chuck McGowin     | EPRI                                       | EPRI manager of TVP                      |
| John Zimmerman    | GMP  | TVP participant                          |
| Jeff Holbrook     | LG&E, West Texas                           | Operator of 135 MW of Kennetech turbines |
| Karen Conover     | Global Energy Concept                      | TVP Coordinator                          |
| Earl Davis        |  | TVP Consultant                           |

+Members of discussion group were outlined as to reasons for participation. TVP Manufacturers, NREL, EPRI, Lightning experts, TVP utilities and operators

### C.3 Participant Presentations

- +Dave McNabb, CSWS, described the CSWS experience with lightning near the Zond windmills.
  - 6,000 ft AMSL, on mountaintops, with 12 Zond Z-40s
  - 2 to 3 flashes per sq km at CSWS site area as noted in CSWS **Handout #1**
  - could have done a better job in advance designing a more lightning-resistant site
  - poor general ground with ufer ground, also 200 ohms
  - some damage caused unexpected costs and downtime, see CSWS **Handout #2**
  - Kithill came in to do improved lightning protection and reduce ground to 10 or 15 ohm
  - trenches with wire and bentonite, retrofit described in CSWS **Handout #1**
  - \$57 K increased cost
  - this is happening but yet to be complete
  - interested in recommendations and help, not interested in standard development
  - will provide info and site for further lightning-damage testing and analysis
  - gave caveats about historical data, inaccurate due to quasi-experimental nature of project
  - did not observe damage from direct strikes on blades
  
- +Kithill, variety of towers hit, met towers hit, plenty of downtime, some safety concerns
  
- +Conover noted that met data has some problems but data recovery is in normal range.
  
- +Kevin Cousineau, Zond, described observations on their mitigation techniques at CSWS site
  - ground strap from generator down droop cable to common ground
  - lightning arrestors, MOVs, controller box grounded, ufer ground
  - ground resistance varied between 25 and 200 ohm
  - averaged 60 ohm
  - would like to see 5 ohm, will put up with 10 ohm
  - added more lightning protection – uptower lightning arrestor
  - argues that personal observations exceed presented CSWS data of 3 hits per km<sup>2</sup>
  - almost every day in the summer it's a constant issue, danger to operators
  - three levels of protection in comm system, fiber optic would have been better
  
- +Steve Jones, SPS, Amarillo, TX, three Carter 300-kW turbines, units have been removed
  - availability was about 80%, history in SPS Handout #1, had several bad periods
  - rod attached to nacelle cover, strap to tower with brush, tower conducted to ground
  - picture of ground cable is included in SPS Handout #1
  - data collection system was frequently damaged
  - tower wrap and flag pot sensors frequently had damage, cost impact unknown
  - surge protectors and isolation was added all over the place
  - much damage coming in from telephone system, MORE THAN AC LINE!
  - loop around all three units was connected to all guy cables, tower bases, and transformers
  - grounding grid with more than 15 ground rods
  - **this grid seemed to help a lot**
  - had raised anemometer but this caused more lightning damage
    - dropping it back down reduced damage significantly
  - protection on telephone and comm were fried but did the job of protection
  - supplied downtime cost and causal documentation in SPS Handout #1,
  - recommends grounding grid, telephone line and incoming mains protection, fiber optic
  - site is 400 miles from CSWS and similar in lightning activity
  - did not observe damage from direct strike

- Carter has leading edge **copper wire in blade**, also lead area is significant
- +Jeff Holbrook, LGE Power, for LCRA,
  - 4800 to 5880 ft AMSL, on shale, sandstone, rock, 122 Kennetech 33 MVS turbines
  - daisy chained RS 422 comm line, have gas discharge tube to protect wire, no arrestors or MOV
  - tremendous amount of lightning, almost every afternoon all summer
  - Costa Rica units has worse lighting problem
  - KWP caused downtime that couldn't be recovered due to bankruptcy, parts materials shortage
  - suspect lost tower due to lightning strike
  - lost many sensors (tachometers, etc) small signal wires, com and sensor boards
  - not much damage in power electronics
  - personal safety at risk
  - blade hit directly, split
  - no lightning rod, no blade wire
  - has grounding grid similar to Zond retrofit
  - fried one whole controller as if it were welded
  - plan on focusing on highest altitude, observed highest strike frequency at these units
  - thinks some indirect destruction of turbine due to overspeed caused by destroyed tach sensors
  - telephone lines are bringing in some damage (telco well protected at site, no collateral damage)
  - LGE is heading KWP (Kennetech) users group
  - operate many other turbine sites, LG&E in it for long term
  - Buffalo Ridge has same problems but lower severity

+Cousineau asked Fort Davis Observatory people what they did, they built site on big buried copper plate. Also has observed several strikes in Tehachapi. Anecdotal.

+Zond was not aware of lightning severity. Kennetech also had same lack of understanding.

+Davis wondered about severity and safety concerns and procedures in response to lightning. Lightning response is get in vehicle and get off the tops of these exposed hills according to Cousineau and Holbrook.

+Chuck McGowin - EPRI, on wind power and TVP project directions

- supplied **EPRI Handout**
- 120 stations in country that are part of National Lightning Detection Network (NLDN) Ken Cummins, Global Atmospheric, Tucson, AZ 1-800-283-4557  
<http://www.gds.com/>
- available in realtime and as database, collected in one place for whole country
- cloud to ground strokes, data about stroke intensity and location
- discussion by Cousineau, McNiff, McNabb, and others regarding proper system protection response to reduce damage to critical systems (telephone, mains, etc) in advance of lightning storm
- NDLN has software to design and evaluate mast and shield site protection systems
- good response to use of a sacrificial/attraction masts to protect units
- noted some research on using a laser path (ionized air) for guiding lightning

10:30 Break

+Ed Muljadi, NREL, on NREL/DOE activities in WTG lightning protection research

- information dissemination, research, investigation on wind turbine lightning problems
- international group was convened, International Energy Agency, see IEA 26th Experts meeting report 8 March 94, see **IEA Handout**
- sources of damage unknown amount of direct and indirect

- utilities get lots of damage, high cost in systems throughout world
- some good references at the end of Muljadi paper in this document, pg. 54
- Davis wonders if there is something coming out of meeting of experts. Nothing toward a standard. A draft of recommendations. Some suggestions are in papers.

+IEC TC81 document exists for stuff but not specifically for wind turbine structures. Are these applicable to wind turbines? If you do it properly according to these standards, then will you protect sufficiently? Should we supplement or write new standards?

+Kithill says lightning rod salesman are writing the American Standards and scientists are writing the European standards. Not good. Stochastic phenomenon that may be solvable as a site-specific issue - it comes into risk management. There is a gap here for the application. McNiff says perhaps a manufacturer will provide a lightning protection package.

11:45 began working lunch

+Rich Kithill, National Lightning Safety Institute, non-profit group,

- see **NLSI Handout** and web page: <http://www.lightningsafety.com/>
- lightning is a stochastic process (location and intensity)
- NLSI addresses with risk management guidelines
- good detector/relays that sense lightning, useful device sometimes
- NLSI is attempting to get away advice from vendors, gatevalve between research and application specifics in the fields
- maps of thunderstorms days (isokeranic), not necessarily an indicator of strike probability
- Global Atmospheric (same as NLDN people) publishes flash density maps of small areas all over U.S., GAI provides site lightning stroke analysis, see info above
- Must learn from wealth of historical data, this is NLSI starting point
- EU funded a global study of lightning damage analysis
- interesting empirical data
  - wood blades less susceptible
  - higher towers more susceptible
- tons of information out there of wind turbines lightning damage and study see list of references and bibliography in **NLSI Handout**
- suggested that we develop a document to guide for wind turbine lightning safety
- there are open questions not addressed by general grounding and protection documents
- the history and application specific references should be assembled as a starting point

+Chester Kawiecki, Lightning Protection Corp., consultants to Zond, **See LPC Handout**

- rather consider it all as transients - much of it is a shielding and grounding issue for surges
- why wouldn't complete Faraday cage work? induction surges may be a problem
- focuses on electrical and control protection
- semi-conductors are the most susceptible to damage from surges
- surge starts as overvoltage phenomena, protection is based solely on that
- both level and duration of expected surge dictate the nature of protection
- spark-gap arrestor doesn't function as ideally as MOV
- MOV device acts as sentinel at the gate, it won't allow overvoltage events to pass
- \* standard reference surge wave shape has peak in 8  $\mu$ s and falls to 50% of peak in 20  $\mu$ s from initiation
- \* MTFB is about 20 years, longer for low currents, shorter for high currents
- \* has indicator lights and relays
- \* available up to 340 kA

- +Cousineau displayed the use of two items in Z40 one in controller another right at generator.
  - what about lower voltage transients? MOVs and silicon junctions are used
  - wire protection for lower voltage can insert L, R, and diode to protect line to line and to ground
  - spark gaps are used to short out the excess voltage upstream of a limiting (zener, etc.) diode
  - gas tube spark gaps have low capacitance and high current capability, good for com lines and low voltage sensor signals
  - Discussion of using opto isolation or conversion to fiber optics for various sensor signals - worth using in some situations.

## **C.4 Discussion, Wrap up, and Planning Recommendations**

- +Butterfield led discussion to boil these issues down to:
  - A. Solvable Problems with existing technology and standards
  - B. Problems requiring investigation

### **C.4.1 Solvable Problems**

1. Characterizing Problems
  - a. Signals - from sensors, com lines, etc.
    - use recommended standards for proper mitigation techniques
  - b. Power - power from the mains
    - use recommended standards for proper mitigation techniques
  - c. Proper grounding and shielding - careful design and installation of proper ground
    - use recommended standards and advice
2. Lessons learned should be documented in an article for the wind industry
  - a. Handout #2 of NLSI as a starting guideline
  - b. DAMAGE SURVEY
    - \* survey to collect data base of damage experience
    - \* easy to do within TVP with failure reports at operators
      - rotating or not
      - protection or not
      - turbine location (high altitude, site, etc.
      - developing
    - \* history of corresponding protection techniques (copper in blades, tip caps, etc.
    - \* onset of lightning event data (wind speed, power level, temperature, etc.)
    - \* what and how was damage (blades, etc.
    - \* why is lightning suspected
    - \* site characterization using lightning database
    - \* definitions page, standard terms from IEEE dictionary
3. Check list of things to include in proper design should be created and disseminated
  - site characterization for ground resistivity and lightning risk

### **C.4.2 Problems requiring investigation**

1. Lightning sensing is worthwhile
  - sensors available
    - what was magnitude of strike/surge?

- event energy transferred
  - counting events
  - locating strike
2. Air streamer air terminals (grounding rod) effectiveness?
    - possibly collects strikes for other turbines onto adjacent tower or same tower
  3. Diverter strips on blades - effectiveness?
  4. Faraday shields (cover) in nacelle - effective? Worthwhile? Further damage risk?
  5. Economic impact of mitigation techniques? Is there diminishing return?
  6. Collate and summarize work done to date that is credible.
  7. What experience in other disciplines are applicable?
  8. Rapid evaluation of a monitoring system for local strikes?

### **C.4.3 Collect various options, costs and effectiveness for all steps**

- Muljadi and McNiff

1. LG&E is applying mitigation techniques on some turbines this season.  
Can we evaluate effectiveness of these techniques?
2. What is statistical requirements to evaluate mitigation techniques
3. Can we translate the NLDN data to calibrate a site for strike risk level?

### **C.5 Observations**

- just because blades strikes are not a problem in Texas (dry) doesn't mean it isn't a problem in wetter areas like Vermont (Equinox Mt had two strikes)
- Windstats article reported on a survey of lightning damage
- Baseline system would be useful
- IEEE PC62 Surge Protection of Electric Generating Plants group (and other national or international groups) should be attended
- Kithil suggests getting at existing database UMIST
- what is applicable techniques for similar fields
- EPRI has unique relationship with GAI, can EPRI/ TVP pull some strings to get data for mean level of strikes at a site? Match to survey
- what is effect on initial cost (mitigation techniques) and operating cost from potential damage (downtime, replacement, unscheduled labor time)
- Jeff says his ground resistance is biggest question
- what about met tower or SCADA or operation building damage
- For any site, is it possible to determine: what is flash density? what is protection system? is this adequate for this site?
- lightning season starts in mid-May
- will turbine owners participate in cost of monitoring system? maybe. They will make sites available and gather data. Will kick in a few grand, but not much. Just need to convince them that is within their interest.
- whose responsibility is lightning damage in a warranty situation?
- what about blade damage? what about characterizing other sites?

### **C.6 Bibliography**

1. IEEE C.62 Draft Standard (Surge Protection of Electric Generating Plants), Draft Standard 22.23
2. Uman, Martin Lightning, Dover Books, 1984
3. Hasse, P. Overvoltage Protection of Low Voltage Systems, IEE Power Series (UK),

ISBN #0-86341-213-0

4. IEEE C.62, 1992 Surge Protection, IEEE 345 East 47th St, New York
5. IEEE Electromagnetic Compatibility Standard Collection, IEEE
6. Windstats article on Lightning, Summer 1994

## **C.7 Closing Business**

**Next meeting** aligned with AWEA Windpower 97 conference 15 to 18 June 1997

## **C.8 Close of Meeting 3:45 p.m.**





## Appendix D - Field Test Documentation

The Appendix includes the documentation and instructions for the Lightning Protection Project Field Test.

### D.1 Data Retrieval Guidelines

The following document is to provide guidance in retrieving data from the CR500 dataloggers in the Lightning Protection Project data acquisition boxes (DAS) at the base of each of the 12 Zond turbines at the CSW Wind Park. Feel free to add to, or subtract from, these guidelines as you see fit, but please maintain a consistency of documentation throughout the Project. For your information, the program for the CR500 is attached.

1. Set laptop clock to desktop computer or Zond SCADA clock (use local time). Attach SC32A interface white cord to COM port.
2. Archive previous data set on laptop directory to avoid over-writing old data (i.e. make it a different directory).
3. Open PC208 software to get Windows menus up and available. It is assumed that SETUP is correct. Click on CONNECT icon.
4. Go to first turbine (start at #1) and do the following:
  - a. check that box is securely attached, adjust as needed.
  - b. open box and check that fibers are in clamps, ground is secure, PC board is secure, and all hardware is not loose.
  - c. plug blue connector from interface into CR500 I/O port
5. Wake up laptop. Click on TOOLS tab. From station list on upper left, pick logger that matches the turbine (e.g., CR500\_1). Click on CONNECT to establish communication between laptop and logger. Click the COLLECT (Manual Data Collection heading) button in the window. Do not use the COLLECT ALL button since we only want the data since the last time it was milked.
6. Check and note difference between datalogger and PC clock (viewable in clock window).
7. Click on SET DATALOGGER CLK to align datalogger clock to the laptop. Click on DISCONNECT to break the COM connection.
8. Disconnect blue connector from I/O port. Secure box cover and:
  - a. check that all three sensors are undamaged and secure.
  - b. check that fibers at sensor end are still attached.
9. Repeat at remaining turbines.
10. Email data to McNiff (bmcniff@hypernet.com) and LaWhite (niels@peppa.shore.net).
11. Please log the time and date and any observations about the DAS boxes and sensors (sensor damage, clock is way off, etc.). It helps if there are problems later.

#### D.1.1 Tools:

- SC32A interface with RS232 connection cord and blue 9 pin cord for CR500 datalogger
- battery powered drill with #2 Phillips bit for opening boxes

### D.2 Program for CR500 Datalogger

VERSION 2.1, July 24, 1997

### D.2.1 Program

**Table 1.**

|          |  |
|----------|--|
| 015      | Execution Time -- 15 seconds   |
| 01: P117 | Datalogger ID  |
| 01:      | 1 LOC: -- X1 is the site turbine number (2 digits)                   |
| 02: P03  | Pulse Counter  |
| 01:      | 2 Repetitions  |
| 02:      | 1 Pulse Counter #P1 & #P2  |
| 03:      | 0 High frequency, 8 bit counters, reset every 1//8 sec (2048 Hz MAX) |
| 04:      | 2 LOC: X2 & X3 locations   |
| 05:      | 1.000 Multiplier   |
| 06:      | 0.000 Offset   |
| 03: P03  | Pulse Counter  |
| 01:      | 1 Repetitions  |
| 02:      | 3 Switch Counter #P3   |
| 03:      | 2 Switch counter configuration                                       |
| 04:      | 4 LOC: X4 location   |
| 05:      | 1.000 Multiplier   |
| 06:      | 0.000 Offset   |
| 04: P33  | X5 = X2 +X3 -- Add up any counts in X2 or X3                         |
| 01:      | 2 Input Location -- X2   |
| 02:      | 3 Input Location -- X3   |
| 03:      | 5 Input Location -- X5   |
| 05: P33  | X6 = X4 +X5 -- Add any counts in X4                                  |
| 01:      | 4 Input Location -- X4   |
| 02:      | 5 Input Location -- X5   |
| 03:      | 6 Input Location -- X6   |
| 06: P89  | IF X6 <> F -- Has a strike registered anywhere?                      |
| 01:      | 6 Input Location -- X6   |
| 02:      | 2 IF X6 <> 0, Then Set Output Flag                                   |
| 03:      | 0.000 F = 0  |
| 04:      | 10 Set Output Flag if STRIKES are true                               |
| 06: P77  | Record Real Time   |
| 01:      | 111 Julian Day, Hr-Min, Sec  |
| 07: P70  | Sample -- samples all counters and the logger ID                     |
| 01:      | 4 Repetitions  |
| 02:      | 1 Input Locations - X1, X2, X3, X4                                   |

### D.2.2 Program Notes

1. The datalogger program is stored as ZAPDET.DLD (zap detection) on the field computer and laptops. The program cannot be compiled in PC208 because of a Campbell Scientific software glitch. ZAPDET was uploaded from a logger that had the program manually corrected on it.
2. If a logger powers down, it needs its clock reset using the laptop, and its ID should be checked.
3. To change datalogger ID, connect the keypad to the logger serial port using the blue, 9-pin ribbon cord. The following keystrokes will get the job done:

**Table D-1. Keypad Programming of Campbell Datalogger**

| Key stroke        | Response | Comment                     |
|-------------------|----------|-----------------------------|
|                   | LOG1     | Appears on screen           |
| *DA(sequentially) | 13:00    | (I think)                   |
| 8A                | 008      | (for unit #8)               |
| 11A               | 011      | (e.g., changes it to #11, ) |
| *0A               | LOG1     | (logging status screen)     |

4. The program is accessed via keypad by entering \*1A and advancing through using the A key. Return to logging using \*0A and waiting for LOG1 to show on screen.
5. Keypad and laptop can be connected at the same time, but activate only one at a time.

### **D.3 Test Documentation and Maintenance**

29 July 1997, ver 1.1

#### **D.3.1 Documentation Instructions**

Please maintain a logbook that just has the documentation for the test equipment in it.

1. After any major lightning storms **check for End-of-Tape indicator light** on wall mounted video system relay box, and/or a high tape time (more than 1.5 hrs). If needed, change tape:
  - a. Rewind tape (tape auto rewinds when it comes to end) and eject.
  - b. Write tape removal time & date on tape label. Send tape to McNiff.
  - c. Label new tape with unit A or B plus time & date, insert tape.
  - d. **Update VCR clock** (using Menu button and arrows) to match PC or SCADA, document difference in time.
  - e. Move through Menu to list of Alarms (when it is commanded on by ESID) and Power Loss, and log the last 3 alarm and outage times.
2. If you **review tape**, but there is plenty of tape left, pushing FF will return the tape to its last mark. It will then be ready to record again when commanded by the ESID.
3. Once a week, **rename the ESID logging data file**:  
 ESID.LOG to ESmmddy.log (mm=month, dd=day, yy = year)  
 Worry not, a new file named ESID.LOG will be automatically created. Please email data to McNiff.
4. Once a week, **rename the ESID logging data file**:
5. **Milk data loggers** once every 2 weeks or after a particularly gnarly storm that causes some juicy damage. (See Data retrieval Guidelines).
6. **Download data from BMI** (manually or by modem) once every 2 weeks. Convert data to ASCII form and email to McNiff.
7. Regularly **inspect equipment**:
  - a. Check cameras and ESID on rooftop once a week for damage and secure mounting. Check for damaged wire or flex conduit.
  - b. Check that all turbines are being viewed (through monitor). Adjust.
  - c. Assure that ESID sensor is communicating with receiver. ESID UP and COMM OK, should be on. If there are question marks on right side of receiver screen - switch the

sensor (on roof) OFF and ON (switch near where fiber optic plugs into box). This usually takes care of it.

- d. Inspect fiber optic line for kinks and abrasions. Tape if questionable.
8. Check that 24 VAC power supply (large brown converter on orange cord under desk) is warm but not so hot that you pull your hand away.
9. When not using the system: **Leave PC monitor, B&W TV, and manual camera power OFF.** This reduces the load on the UPS, thereby providing for longer operation when the power is lost.
10. Please use **StormScope system** when storms move through and record when possible. Make observations regarding ease of use and usefulness.
11. Please use **Guardian Angel handheld device** in various locations: in truck, inside turbine nacelle, in town at office, at home on windowsill. Make observations regarding ease of use and usefulness.

#### **D.4 Layouts and Circuits**

The system components, assembly and operation have been thoroughly documented for clarity of operation and ease of maintenance and troubleshooting. The following figures were provided to the site personnel and installed in the Test Log book.

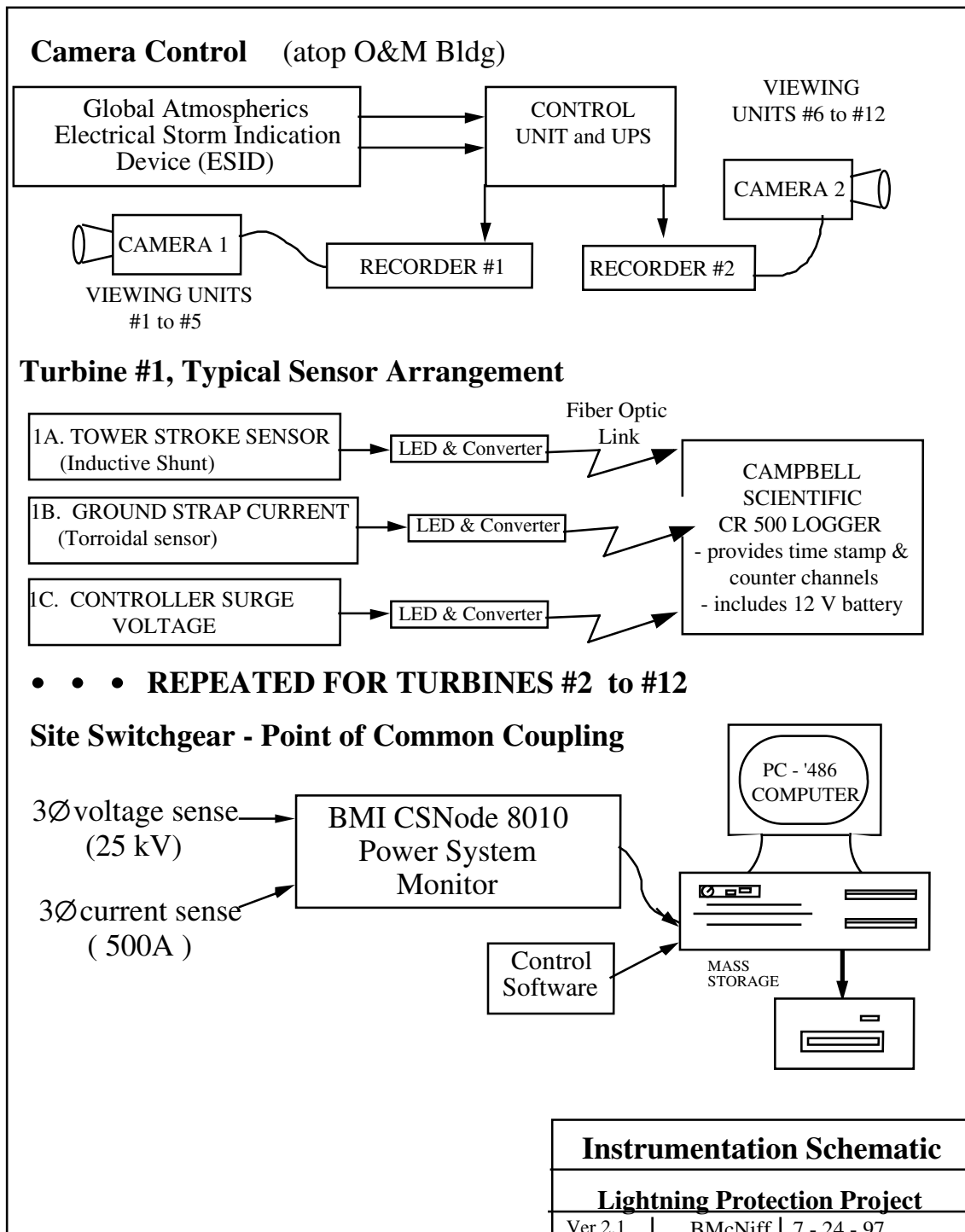

Figure D-1. LPP instrumentation schematic

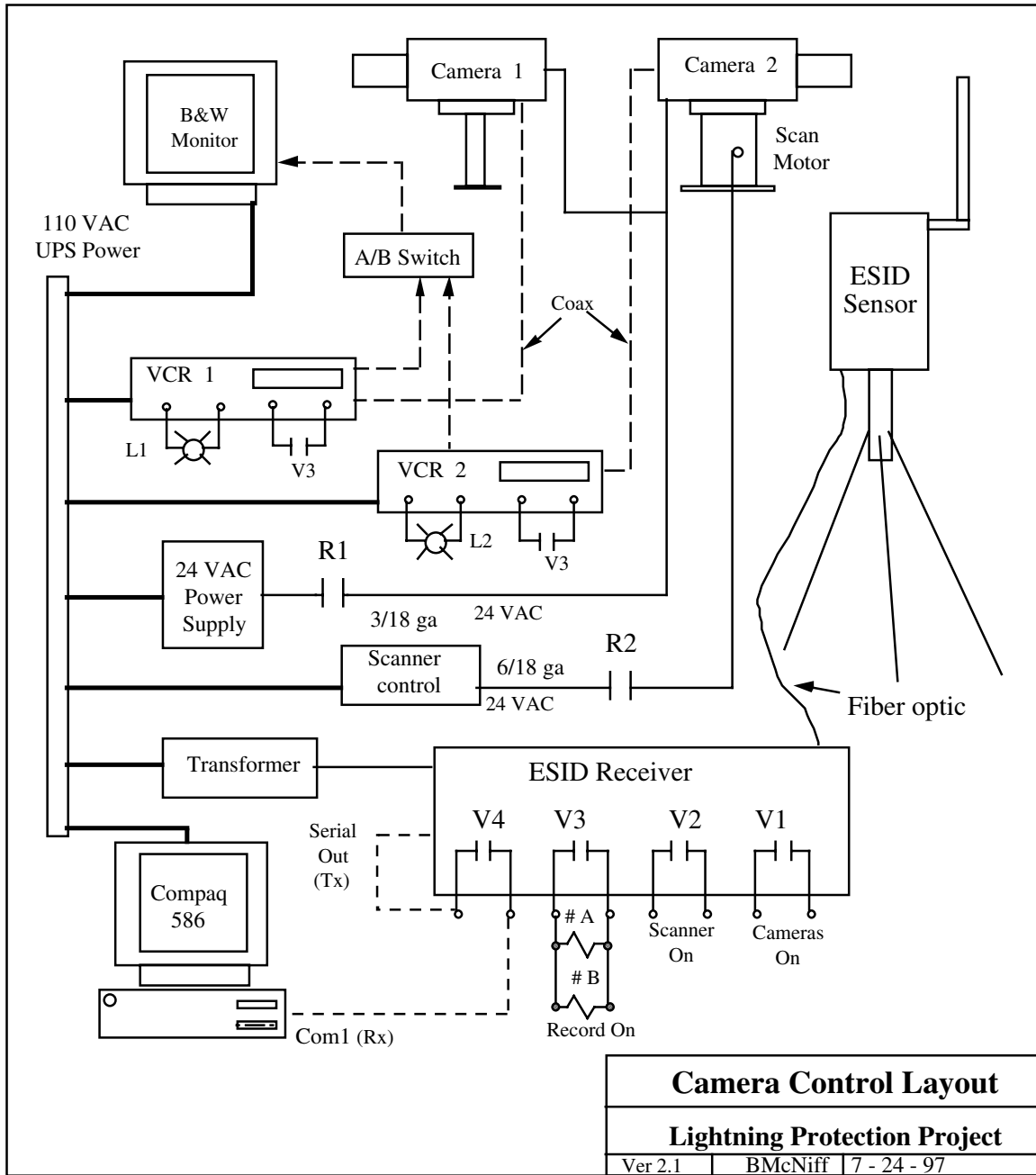

Figure D-2. LPP camera control

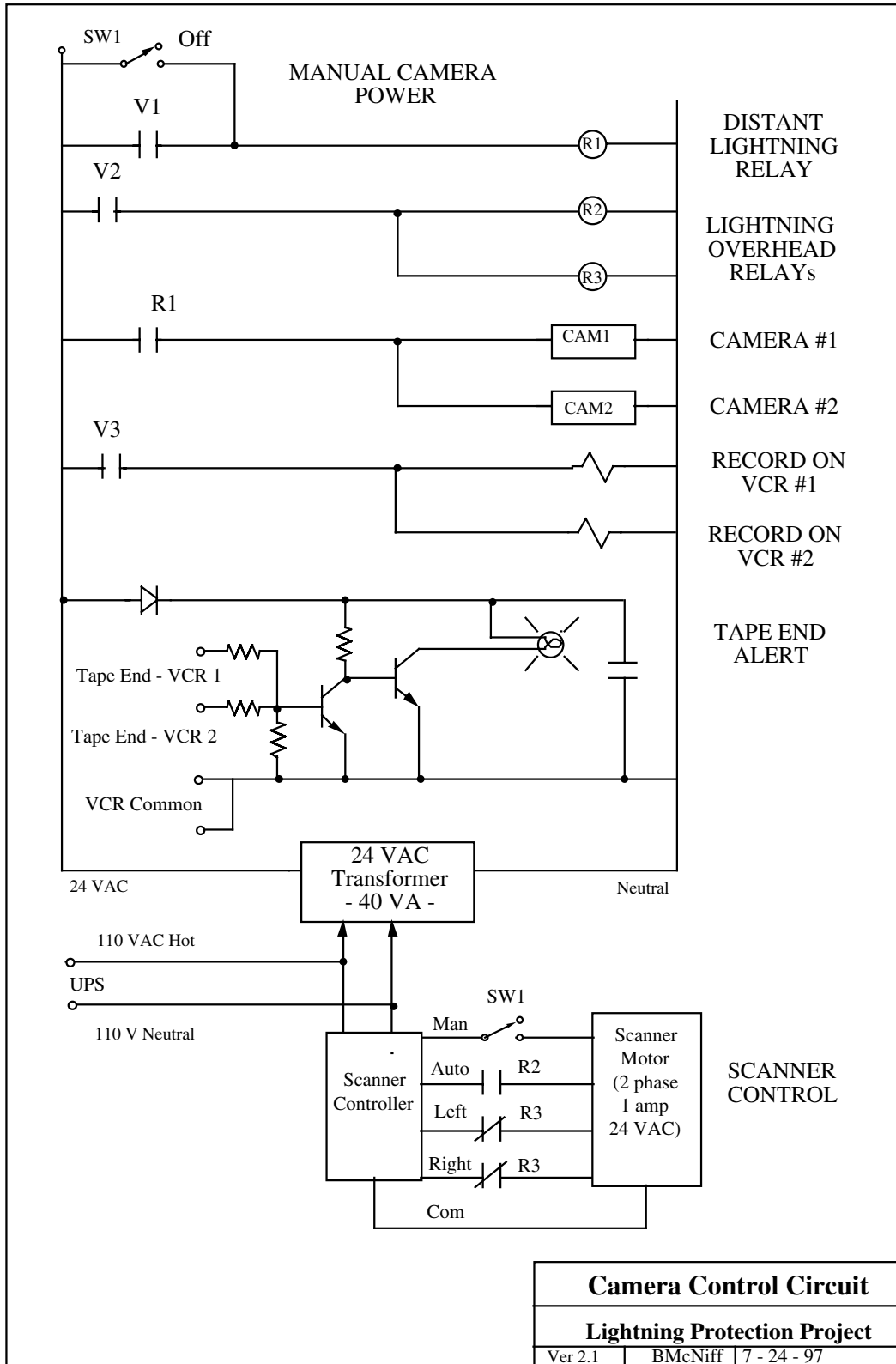

Figure D-3. LPP camera circuit





## Appendix E: IVPC Statistics

Table E-1. IVPC Turbine Lightning Damage

| Turbine | Stage | Type | Install Date | Occur Date | Blade Age (yrs) | Work Performed  | Lightning Protection | Estimated Cost (USD) |
|---------|-------|------|--------------|------------|-----------------|---|----------------------|----------------------|
| D05     | A     | V42  | 4/25/96      | 11/9/96    | 0.54            | <b>1 Blade changed</b>  | N                    | \$45,000             |
| D05     | A     | V42  | 11/9/96      | 5/14/97    | 0.51            | <b>1 Blade changed</b>  | Y (type 1)           | \$45,000             |
| A01     | A     | V42  | 4/11/96      | 7/21/97    | 1.28            | <b>1 Blade changed</b>  | N                    | \$45,000             |
| A07     | A     | V42  | 4/5/96       | 9/2/97     | 1.41            | 1 Blade repaired  | N                    | \$1,900              |
| D05     | A     | V42  | 11/9/96      | 9/11/97    | 0.84            | 1 Blade repaired  | Y (type 1)           | \$1,900              |
| F03     | A     | V42  | 12/12/96     | 9/17/97    | 0.76            | 1 Blade repaired  | N                    | \$1,900              |
| B02     | A     | V42  | 4/19/96      | 12/31/97   | 1.70            | No damage at blades   | N                    |                      |
| E30     | A     | V44  | 10/1/97      | 1/14/98    | 0.29            | No damage at blades   | Y (type 2)           |                      |
| F40     | A     | V42  | 12/13/96     | 5/11/98    | 1.41            | 2 Blades Repaired   | N                    | \$3,800              |
| F20     | A     | V42  | 12/16/96     | 5/22/98    | 1.43            | 1 Blade repaired  | N                    | \$1,900              |
| E11     | A     | V44  | 10/1/97      | 6/13/98    | 0.70            | <b>1 Blade changed</b>  | N                    | \$45,000             |
| EE2     | A     | V44  | 10/1/97      | 6/18/98    | 0.71            | 1 Blade repaired  | Y (type 2)           | \$1,900              |
| F19     | A     | V42  | 12/19/96     | 6/20/98    | 1.50            | 1 Blade repaired  | N                    | \$1,900              |
| E19     | A     | V44  | 10/1/97      | 8/5/98     | 0.84            | No damage at blades   | Y (type 2)           |                      |
| E29     | A     | V44  | 10/1/97      | 8/7/98     | 0.85            | 1 Blade repaired,<br><b>Generator burned out and replaced</b> | Y (type 2)           | \$50,000             |
| J14     | C     | V44  | 9/26/98      | 1/27/99    | 0.34            | No damage at blades   | Y (type 2)           |                      |
| I02     | C     | V44  | 10/22/98     | 4/6/99     | 0.45            | No damage at blades   | Y (type 2)           |                      |
| H30     | C     | V44  | 12/19/98     | 4/20/99    | 0.33            | No damage at blades   | Y (type 2)           |                      |
| B21     | B     | V44  | 5/28/98      | 5/3/99     | 0.93            | <b>2 Blades changed</b>                                       | Y (type 2)           | \$90,000             |
| L03     | C     | V44  | 9/9/98       | 5/28/99    | 0.72            | No damage at blades   | Y (type 2)           |                      |
| L02     | C     | V44  | 9/9/98       | 6/4/99     | 0.73            | No damage at blades   | Y (type 2)           |                      |
| J14     | C     | V44  | 9/26/98      | 6/11/99    | 0.71            | No damage at blades   | Y (type 2)           |                      |
| L04     | C     | V44  | 10/7/98      | 6/12/99    | 0.68            | 1 Blade repaired  | Y (type 2)           | \$1,900              |
| EE4     | A     | V44  | 10/1/97      | 6/15/99    | 1.70            | 1 Blade repaired  | Y (type 2)           | \$1,900              |
| J17     | C     | V44  | 9/25/98      | 6/17/99    | 0.73            | No damage at blades   | Y (type 2)           |                      |
| J18     | C     | V44  | 9/25/98      | 6/23/99    | 0.74            | No damage at blades   | Y (type 2)           |                      |
| L05     | C     | V44  | 10/6/98      | 7/13/99    | 0.77            | No damage at blades   | Y (type 2)           |                      |
| L06     | C     | V44  | 10/6/98      | 7/26/99    | 0.80            | No damage at blades   | Y (type 2)           |                      |
| F15     | A     | V42  | 12/17/96     | 9/8/99     | 2.73            | No damage at blades   | N                    |                      |
| R03     | sp    | V44  | 4/17/99      | 9/24/99    | 0.44            | 1 Blade Repaired  | Y (type 2)           | \$1,900              |
| J03     | C     | V44  | 8/20/98      | 10/6/99    | 1.13            | 1 Blade Repaired  | Y (type 2)           | \$1,900              |
| R02     | (sp)  | V44  | 4/17/99      | 11/27/99   | 0.61            | No damage at blades   | Y (type 2)           |                      |
| J17     | C     | V44  | 9/25/98      | 12/1/99    | 1.18            | No damage at blades   | Y (type 2)           |                      |
| B22     | B     | V44  | 5/23/98      | 1/11/00    | 1.64            | 1 Blade Repaired  | Y (type 2)           | \$1,900              |
| F01     | A     | V42  | 12/12/96     | 2/11/00    | 3.17            | 1 Blade repaired  | Y (type 1)           | \$1,900              |
| B21     | B     | V44  | 5/3/99       | 2/23/00    | 0.81            | 2 Blades repaired   | Y (type 2)           | \$3,800              |
| B22     | B     | V44  | 5/23/98      | 2/23/00    | 1.76            | 1 Blade repaired  | Y (type 2)           | \$1,900              |
| B11     | B     | V44  | 6/14/98      | 4/20/00    | 1.85            | 1 Blade repaired  | Y (type 2)           | \$1,900              |
| H06     | C     | V44  | 12/3/98      | 4/20/00    | 1.38            | No damage at blades   | Y (type 2)           |                      |
| D05     | A     | V42  | 11/9/96      | 4/21/00    | 3.45            | 1 Blade repaired  | Y (type 1)           | \$1,900              |
| F29     | B     | V42  | 12/13/96     | 5/2/00     | 3.39            | 1 Blade repaired  | Y (type 1)           | \$1,900              |

|     |   |     |         |         |      |                        |            |          |
|-----|---|-----|---------|---------|------|------------------------|------------|----------|
| L01 | C | V44 | 9/4/98  | 5/3/00  | 1.66 | No damage at blades    | Y (type 2) |          |
| E24 | A | V44 | 10/1/97 | 5/5/00  | 2.59 | <b>1 Blade Changed</b> | Y (type 2) | \$45,000 |
| J14 | C | V44 | 9/26/98 | 5/24/00 | 1.66 | <b>1 Blade Changed</b> | Y (type 2) | \$45,000 |
| H17 | C | V44 | 1/18/98 | 6/1/00  | 2.37 | 2 Blades repaired      | Y (type 2) | \$90,000 |
| E15 | A | V44 | 10/1/97 | 6/17/00 | 2.71 | No damage at blade     | Y (type 2) |          |
| E27 | A | V44 | 10/1/97 | 6/26/00 | 2.74 | <b>1 Blade Changed</b> | Y (type 2) | \$45,000 |
| J20 | C | V42 | 1/7/99  | 7/28/00 | 1.56 | 1 Blade repaired       | Y (type 2) | \$1,900  |
| J29 | C | V44 | 1/25/99 | 7/31/00 | 1.52 | 1 Blade repaired       | Y (type 2) | \$1,900  |
| B10 | B | V44 | 6/15/98 | 8/2/00  | 2.13 | 1 Blade repaired       | Y (type 2) | \$1,900  |
| B25 | B | V44 | 5/28/98 | 8/4/00  | 2.19 | 1 Blade repaired       | Y (type 2) | \$1,900  |
| B27 | B | V44 | 5/22/98 | 8/9/00  | 2.22 | 1 Blade repaired       | Y (type 2) | \$1,900  |
| C24 | D | V44 | 1/14/00 | 8/24/00 | 0.61 | 1 Blade repaired       | Y (type 2) | \$1,900  |
| K01 | C | V44 | 10/5/98 | 8/25/00 | 1.89 | 1 Blade repaired       | Y (type 2) | \$1,900  |
| B13 | B | V44 | 6/3/98  | 9/29/00 | 2.33 | 1 Blade repaired       | Y (type 2) | \$45,000 |

| REPORT DOCUMENTATION PAGE  |   |  | Form Approved<br>OMB NO. 0704-0188   |
|--|---|--|--------------------------------------|
| Public reporting burden for this collection of information is estimated to average 1 hour per response, including the time for reviewing instructions, searching existing data sources, gathering and maintaining the data needed, and completing and reviewing the collection of information. Send comments regarding this burden estimate or any other aspect of this collection of information, including suggestions for reducing this burden, to Washington Headquarters Services, Directorate for Information Operations and Reports, 1215 Jefferson Davis Highway, Suite 1204, Arlington, VA 22202-4302, and to the Office of Management and Budget, Paperwork Reduction Project (0704-0188), Washington, DC 20503. |   |  |                                      |
| 1. AGENCY USE ONLY (Leave blank)   | 2. REPORT DATE<br>May 2002                                  | 3. REPORT TYPE AND DATES COVERED<br>Subcontract Report 1999-2001           |                                      |
| 4. TITLE AND SUBTITLE<br>Wind Turbine Lightning Protection Project   |   | 5. FUNDING NUMBERS<br><br>WE61.4400<br>WE80.3060<br>WE80.4030              |                                      |
| 6. AUTHOR(S)<br>Brian McNiff   |   |  |                                      |
| 7. PERFORMING ORGANIZATION NAME(S) AND ADDRESS(ES)<br>McNiff Light Industry<br>43 Dog Island Road<br>Harborside, ME 04642  |   | 8. PERFORMING ORGANIZATION<br>REPORT NUMBER                                |                                      |
| 9. SPONSORING/MONITORING AGENCY NAME(S) AND ADDRESS(ES)<br>National Renewable Energy Laboratory<br>1617 Cole Blvd.<br>Golden, CO 80401-3393  |   | 10. SPONSORING/MONITORING<br>AGENCY REPORT NUMBER<br><br>NREL/SR-500-31115 |                                      |
| 11. SUPPLEMENTARY NOTES<br><br>NREL Technical Monitor: E. Muljadi  |   |  |                                      |
| 12a. DISTRIBUTION/AVAILABILITY STATEMENT<br>National Technical Information Service<br>U.S. Department of Commerce<br>5285 Port Royal Road<br>Springfield, VA 22161   |   | 12b. DISTRIBUTION CODE   |                                      |
| 13. ABSTRACT (Maximum 200 words)<br>A lightning protection research and support program was instituted by NREL to help minimize lightning damage to wind turbines in the United States. This paper provides the results of a field test program, an evaluation of protection on selected turbines, and a literature search as well as the dissemination of the accumulated information.  |   |  |                                      |
| 14. SUBJECT TERMS<br>wind turbine; power system; wind farm; renewable energy; lightning; damage  |   | 15. NUMBER OF PAGES  | 16. PRICE CODE                       |
| 17. SECURITY CLASSIFICATION<br>OF REPORT<br>Unclassified   | 18. SECURITY CLASSIFICATION<br>OF THIS PAGE<br>Unclassified | 19. SECURITY CLASSIFICATION<br>OF ABSTRACT<br>Unclassified                 | 20. LIMITATION OF ABSTRACT<br><br>UL |