

# TurbSim User's Guide: Version 1.06.00

B.J. Jonkman, L. Kilcher

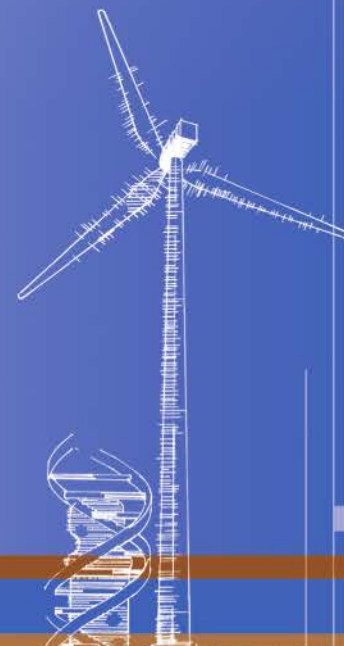
Revised September 19, 2012  
for TurbSim version 1.06.00

**DRAFT VERSION**

**Technical Report**

**NREL/TP-xxx-xxxx**

**September 2012**



NREL is operated for DOE by the Alliance for Sustainable Energy, LLC Contract No. DE-AC36-08-GO28308



# TurbSim User's Guide: Version 1.06.00

B.J. Jonkman, L. Kilcher

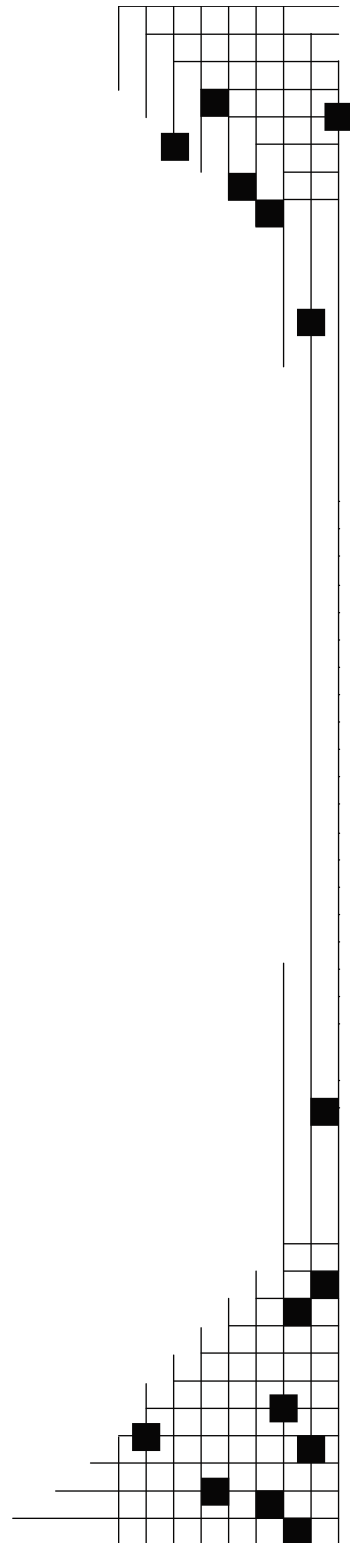
Prepared under Task Nos. WER8.2102, WA093101, and WE110331

**DRAFT VERSION**

*Technical Report*

NREL/TP-xxx-xxxx

September 2012



**National Renewable Energy Laboratory**  
1617 Cole Boulevard, Golden, Colorado 80401-3393  
303-275-3000 • [www.nrel.gov](http://www.nrel.gov)

Operated for the U.S. Department of Energy  
Office of Energy Efficiency and Renewable Energy  
by the Alliance for Sustainable Energy, LLC

Contract No. DE-AC36-08-GO28308

## NOTICE

The submitted manuscript has been offered by an employee of the Alliance for Sustainable Energy, LLC (ASE), a contractor of the US Government under Contract No. DE-AC36-08-GO28308. Accordingly, the US Government and ASE retain a nonexclusive royalty-free license to publish or reproduce the published form of this contribution, or allow others to do so, for US Government purposes.

This report was prepared as an account of work sponsored by an agency of the United States government. Neither the United States government nor any agency thereof, nor any of their employees, makes any warranty, express or implied, or assumes any legal liability or responsibility for the accuracy, completeness, or usefulness of any information, apparatus, product, or process disclosed, or represents that its use would not infringe privately owned rights. Reference herein to any specific commercial product, process, or service by trade name, trademark, manufacturer, or otherwise does not necessarily constitute or imply its endorsement, recommendation, or favoring by the United States government or any agency thereof. The views and opinions of authors expressed herein do not necessarily state or reflect those of the United States government or any agency thereof.

Available electronically at <http://www.osti.gov/bridge>

Available for a processing fee to U.S. Department of Energy and its contractors, in paper, from:

U.S. Department of Energy  
Office of Scientific and Technical Information  
P.O. Box 62  
Oak Ridge, TN 37831-0062  
phone: 865.576.8401  
fax: 865.576.5728  
email: <mailto:reports@adonis.osti.gov>

Available for sale to the public, in paper, from:

U.S. Department of Commerce  
National Technical Information Service  
5285 Port Royal Road  
Springfield, VA 22161  
phone: 800.553.6847  
fax: 703.605.6900  
email: [orders@ntis.fedworld.gov](mailto:orders@ntis.fedworld.gov)  
online ordering: <http://www.ntis.gov/ordering.htm>



Printed on paper containing at least 50% wastepaper, including 20% postconsumer waste

## **Acknowledgements**

TurbSim was written by Bonnie Jonkman at the National Wind Technology Center (NWTC). Funding for TurbSim came from the U.S. Department of Energy under contract No. DE-AC36-08-GO28308 to NREL.

Analysis of coherent events was performed by Neil Kelley, Bonnie Jonkman, and George Scott of the National Wind Technology Center, and Professor Jan Bialasiewicz, and Lisa Redmond of the University of Colorado at Denver.

The turbulence modeling scaling parameters for the GP\_LLJ and NWTCUP spectral models were developed by Neil Kelley and Bonnie Jonkman. Neil Kelley developed scaling parameters for the National Renewable Energy Laboratory wind farm models.

Levi Kilcher of the National Wind Technology Center added the NREL/UW Tidal Channel (TIDAL) spectral model to extend TurbSim's use for water turbulence.

## List of Abbreviations

ART	Advanced Research Turbine
BLAS	Basic Linear Algebra Subprograms
CoRA	Colorado Research Associates
CTKE	coherent turbulent kinetic energy
CXML	Compaq Extended Math Library
DNS	direct numerical simulation
ETM	Extreme Turbulence Model
EWM	Extreme Wind Model
FF	full field
FFT	Fast Fourier Transform
FFTPACK	FFT Package
HH	hub height
IEC	International Electrotechnical Commission
LAPACK	Linear Algebra Package
LES	large-eddy simulation
LIST	Long-Term Inflow and Structural Testing
LLLJP	Lamar Low-Level Jet Project
MHK	marine and hydrokinetic
NCAR	National Center for Atmospheric Research
NREL	National Renewable Energy Laboratory
NTM	Normal Turbulence Model
NWTC	National Wind Technology Center
pRNG	pseudorandom number generator
SONIC	sonic detection and ranging
TI	turbulence intensity
TKE	turbulent kinetic energy

# Table of Contents

Acknowledgements .....	iii
List of Abbreviations .....	iv
Table of Contents .....	v
List of Figures .....	vii
List of Tables .....	ix
Introduction.....	1
History .....	1
Retrieving Files from the Archive .....	2
Distributed Files .....	3
Certification Test .....	3
Compiling TurbSim.....	4
Using TurbSim .....	4
Input File.....	5
Runtime Options .....	6
Turbine/Model Specifications .....	8
Meteorological Boundary Conditions.....	12
Non-IEC Meteorological Boundary Conditions.....	17
Coherent Turbulence Scaling Parameters .....	23
Output Files.....	25
Summary Files.....	25
Hub-Height Binary Files.....	25
Hub-Height Formatted Files .....	26
Hub-Height AeroDyn Formatted Files .....	26
Full-Field TurbSim Binary Files .....	27
Full-Field Bladed-Style Binary Files.....	27
Tower Data Binary Files .....	27
Full-Field Formatted Files.....	28
Coherent Turbulence Time-Step Files .....	28
Spectral Models .....	30
IECKAI: The IEC Kaimal Model.....	30
IECVKM: The IEC Von Karman Isotropic Model.....	31
SMOOTH: The Risø Smooth-Terrain Model .....	31
NWTCUP: The NREL National Wind Technology Center Model .....	34
GP_LLJ: The NREL Great Plains Low-Level Jet Model.....	35
WF_UPW: The NREL Wind Farm, Upwind Model .....	36

WF_14D: The NREL Wind Farm, Downwind Model (14 Rotor Diameters).....	37
WF_07D: The NREL Wind Farm, Downwind Model (7 Rotor Diameters).....	38
TIDAL: The NREL/UW Tidal Channel Model .....	39
Spatial Coherence Models .....	39
Coherence for IEC Spectral Models .....	40
Coherence for Non-IEC Spectral Models .....	40
Wind (Velocity) Profiles .....	41
Power-Law Wind Profile .....	41
Logarithmic Wind Profile.....	41
Logarithmic Water Profile .....	42
IEC Wind Profile .....	42
Low-Level Jet Wind Profile .....	42
Coherent Structures .....	43
Adding and Scaling the Coherent Structures .....	44
Using Coherent Turbulence Time-Step Files with AeroDyn.....	45
Suggestions for Generating Coherent Turbulent Structures .....	47
Warnings .....	47
Limitations .....	48
Possible Future Enhancements .....	48
Caveats .....	48
Disclaimer.....	48
Feedback.....	49
References.....	50
Appendix A: Sample TurbSim Input File .....	53
Appendix B: TurbSim Quick-Start Guidelines for IEC Turbulence.....	54
Appendix C: Flow Charts .....	56
Appendix D: Full-Field TurbSim Binary File Format.....	64
Appendix E: Full-Field Bladed-Style Binary File Format.....	66
Appendix F: Tower Data Binary File Format.....	68
Appendix G: Velocity Spectra Comparison Plots.....	70
Appendix H: Sample AeroDyn Coherent Turbulence Parameter Input File .....	76

## List of Figures

Figure 1. TurbSim simulation method: a transformation from the frequency domain to time domain producing wind output compatible with AeroDyn; optional coherent structures are written to a separate file and superimposed in AeroDyn (they require a full-field background wind file) .....	1
Figure 2. Example TurbSim command line output.....	4
Figure 3. Coordinates of a TurbSim wind field with 15° horizontal and 8° vertical mean flow angles .....	5
Figure 4. Example of tower points below a rectangular grid.....	7
Figure 5. Example grid and rotor placements: the circles pictured here are the rotor diameters assumed by TurbSim; the actual rotor diameter(s) will be smaller than pictured .....	10
Figure 6. Example of TurbSim grids as implemented in AeroDyn: (a) The inertial frame coordinate systems and planes “marching” along positive X, regardless of flow angles, (b) wind field with both flow angles 0°, (c) the same wind field with $VFlowAng = 8^\circ$ and $HFlowAng = 15^\circ$ .....	11
Figure 7. Longitudinal wind-speed standard deviation and TI for IEC turbulence categories as functions of the mean hub-height wind speed, $V_{hub}$ .....	13
Figure 8. Coherent turbulent kinetic energy (CTKE) of an example simulation using KHTEST: the coherent structure placement in the middle of the time series is shown by the red lines .....	14
Figure 9. Default jet wind speed for $URef$ calculation: error bars indicate the range of random variate, $N$ ; dotted lines mark the tenth and ninetieth percentiles .....	16
Figure 10. Default jet height, $ZJetMax$ , without random variates (the random variation range is approximately $\pm 50$ m) .....	16
Figure 11. Diabatic friction velocity, $u_{*0}$ , normalized by $URef$ and calculated using $RefHt = 80$ m and $Z0 = 0.01$ m .....	19
Figure 12. Default $UStar$ as a function of diabatic friction velocity, $u_{*0}$ (left: SMOOTH, GP_LLJ, and NWTCCUP models, right: wind farm models).....	19
Figure 13. Default $u$ -component coherence parameters, $IncDec1$ , ( $a_u$ left, $b_u$ right) as a function of wind speed, using $RICH\_NO = 0$ and $HubHt = 80$ m (IEC values are plotted for comparison) .....	21
Figure 14. Default $v$ -component coherence parameters, $IncDec2$ , ( $a_v$ left, $b_v$ right) as a function of wind speed, using $RICH\_NO = 0$ and $HubHt = 80$ m (IEC does not define $v$ -component coherence parameters) .....	22
Figure 15. Default $w$ -component coherence parameters, $IncDec3$ , ( $a_w$ left, $b_w$ right) as a function of wind speed, using $RICH\_NO = 0$ and $HubHt = 80$ m (IEC does not define $w$ -component coherence parameters) .....	23
Figure 16. Coherent structure scaling (looking downwind): $CTLy$ is the tower location, $CTLz$ is the hub (height) location, and $DistSc1$ determines the size (m) relative to the rotor disk .....	25
Figure 17. Example TurbSim FF and HH wind files as implemented in AeroDyn. ....	29
Figure 18. SMOOTH-model stable/neutral turbulence as a function of $RICH\_NO$ : left: standard deviation normalized by $UStar$ , right: Relationships between components’ standard deviations.....	32
Figure 19. NWTCCUP-model stable/neutral turbulence as a function of $RICH\_NO$ : left: standard deviation normalized by $UStar$ , right: relationships between components’ standard deviations .....	34
Figure 20. GPLLJ-model stable/neutral turbulence as a function of local stability and shear velocities ....	36



Figure 21. WF_UPW-model stable/neutral turbulence as a function of <i>RICH_NO</i> : left: standard deviation normalized by <i>UStar</i> , right: relationships between components' standard deviations .....	37
Figure 22. WF_07D- and WF_14D-model stable/neutral turbulence as a function of <i>RICH_NO</i> : left: standard deviation normalized by <i>UStar</i> , right: ratios of standard deviations .....	38
Figure 24. Example wind-speed profiles generated in TurbSim for the GP_LLJ model using a 90-m hub-height wind speed of 12 m/s, and <i>RICH_NO</i> = 0.05 .....	42
Figure 25. Example jet wind profiles with a 12 m/s wind speed at 80 m and <i>RICH_NO</i> = 0.05.....	43
Figure 26. Coherent structures in a 10-minute period from the NWTC LIST dataset: the time series shows the 3-s mean CTKE (solid black line) crossing the dashed threshold line, which indicates the location of the coherent structures (indicated in blue) .....	44
Figure 27. Example time series from the NWTCUP model: the black line indicates the background wind file; the green shows the addition of events in a coherent time-step file (".cts") .....	45
Figure A-1. Sample TurbSim input file .....	53
Figure B-1. Sample TurbSim input file for IEC turbulence: parameters shown in blue should be changed based on the turbine configuration; parameters shown in red should be changed for each load case and simulation.....	55
Figure C-1. Overview of the TurbSim simulation method; blue lines indicate processes influenced by input-file parameters; black lines indicate internal variables and processes .....	56
Figure C-2. Parameters in the Runtime Options section of the input file.....	57
Figure C-3. Parameters in the Turbine/Model Specifications section of the TurbSim input file .....	58
Figure C-4. Parameters in the Meteorological Boundary Conditions section of the TurbSim input file (for IECKAI and IECVKM models only).....	59
Figure C-5. Parameters in the Meteorological Boundary Conditions section of the TurbSim input file (for models other than IECKAI and IECVKM).....	60
Figure C-6. Parameters in the Non-IEC Meteorological Boundary Conditions section of the TurbSim input file .....	61
Figure C-7. Default input values for the for the Meteorological Boundary Conditions and Non-IEC Meteorological Boundary Conditions sections of the TurbSim input file .....	62
Figure C-8. Parameters for coherent structures and the Coherent Turbulence Scaling Parameters section of the TurbSim input file; the SMOOTH model uses the GP_LLJ scaling.....	63
Figure G-1. Neutral velocity spectra for the 8 spectral models available in TurbSim, using a 15 m/s wind speed at 80 m; IECKAI and IECVKM use NTM category "B" and 61400-1 3 <sup>rd</sup> ed. scaling; the non-IEC models use <i>RICH_NO</i> = 0 and <i>UStar</i> = "default" .....	70
Figure G-2. Neutral velocity spectra for the 8 spectral models available in TurbSim, using a 15 m/s wind speed at 80 m; IECKAI and IECVKM use NTM category "B" and 61400-1 3 <sup>rd</sup> ed. scaling; the non-IEC models use <i>RICH_NO</i> = 0 and <i>UStar</i> = 1.1 m/s.....	71
Figure G-3. Stable velocity spectra using a 15 m/s wind speed at 80 m; the non-IEC models use <i>RICH_NO</i> = 0.05 and <i>UStar</i> = "default"; The IEC models, which are neutral ( <i>RICH_NO</i> = 0), were added for reference; they use NTM category "B" and 61400-1 3 <sup>rd</sup> ed. scaling .....	72
Figure G-4. Stable velocity spectra using a 15 m/s wind speed at 80 m; the non-IEC models use <i>RICH_NO</i> = 0.05 and <i>UStar</i> = 1.1 m/s; the IEC models, which are neutral ( <i>RICH_NO</i> = 0), were added for reference; they use NTM category "B" and 61400-1 3 <sup>rd</sup> ed. scaling .....	73
Figure G-5. Unstable velocity spectra using a 15 m/s wind speed at 80 m; the non-IEC models use <i>RICH_NO</i> = -0.05 and <i>UStar</i> = "default"; the IEC models, which are neutral ( <i>RICH_NO</i> = 0), were added for reference; they use NTM category "B" and 61400-1 3 <sup>rd</sup> ed. scaling .....	74

Figure G-6. Unstable velocity spectra using a 15 m/s wind speed at 80 m; the non-IEC models use  $RICH\_NO = -0.05$  and  $UStar = 1.1$  m/s; the IEC models, which are neutral ( $RICH\_NO = 0$ ), were added for reference; they use NTM category “B” and 61400-1 3<sup>rd</sup> ed. scaling ..... 75

Figure H-1. Sample AeroDyn coherent turbulence parameter input file ..... 76

## List of Tables

Table 1. Files in the TurbSim Archive ..... 3

Table 2. Definitions of TurbSim Wind-Component Coordinate Systems ..... 5

Table 3. Valid *Scale/IEC* Values ..... 9

Table 4. Valid TurbSim Spectral Models ..... 12

Table 5. Valid IEC Turbulence Models ..... 14

Table 6. Valid Wind Profile Types ..... 15

Table 7. Default Inputs for Meteorological Boundary Conditions ..... 17

Table 8. Valid *CTEventFile* Entries ..... 24

Table 9. Parameters in Hub-Height Binary and Formatted Files ..... 26

Table 10. Format of Hub-Height AeroDyn Files ..... 26

Table 11. Coherent Structure Peak CTKE Scaling ..... 46

Table D-1. Full-Field TurbSim Binary File Header Format ..... 64

Table D-2. FF TurbSim Binary File Grid Format ..... 65

Table E-1. Full-Field Bladed-Style Binary File Header Format ..... 66

Table E-2. Format of Grid Velocities in Full-Field Bladed-Style Binary File Format ..... 67

Table F-1: Format of Header in TurbSim Binary Tower-Data File ..... 68

Table F-2: Format of Grid Velocities in TurbSim Binary Tower-Data File ..... 68

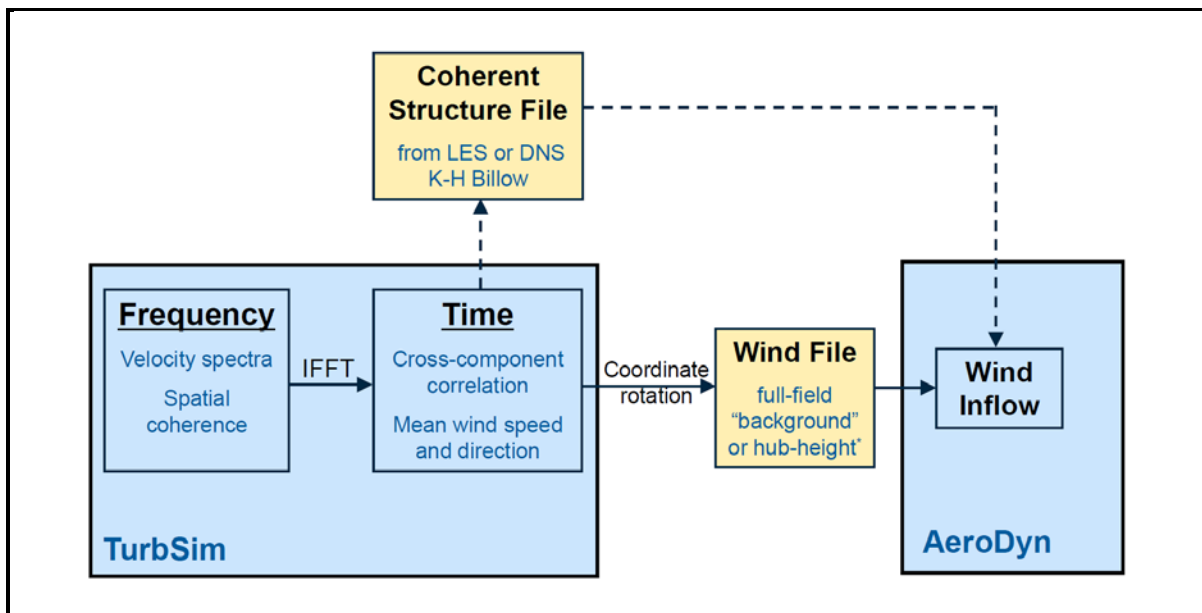
## Introduction

TurbSim is a stochastic, full-field, turbulent-wind simulator. It uses a statistical model (as opposed to a physics-based model) to numerically simulate time series of three-component wind-speed vectors at points in a two-dimensional vertical rectangular grid that is fixed in space. TurbSim output can be used as input into AeroDyn-based [1] codes such as FAST [2] or MSC.ADAMS® [3]. AeroDyn's InflowWind module uses Taylor's frozen turbulence hypothesis to obtain local wind speeds, interpolating the TurbSim-generated fields in both time and space.

Spectra of velocity components and spatial coherence are defined in the frequency domain, and an inverse Fourier transform produces time series. The underlying theory behind this method of simulating time series assumes a stationary process. To simulate non-stationary components, TurbSim—used with AeroDyn—can superimpose coherent turbulent structures onto the time series it generates. The basic simulation method is summarized in Figure 1.

## History

In 1988, Paul Veers of Sandia National Laboratories wrote a program called SNLWIND [4] that could generate full-field turbulent wind for the streamwise ( $u$ ) component only. In 1992, Neil Kelley of the National Renewable Energy Laboratory (NREL) added several spectral models to SNLWIND and modified it to generate the  $v$  and  $w$  components [5]. SNLWIND-3D was the result. During the next five years NREL researchers modified the program further, including adding the Kaimal and von Karman spectral models specified by the International Electrotechnical Commission (IEC). Gary Desrochers modified it to run on many different platforms by including C-preprocessor directives for conditional compilation. In 1997, Marshall



**Figure 1. TurbSim simulation method: a transformation from the frequency domain to time domain producing wind output compatible with AeroDyn; optional coherent structures are written to a separate file and superimposed in AeroDyn (they require a full-field background wind file)**

Buhl added the ability to generate binary files that are compatible with Garrad Hassan's "GH Bladed" turbine design code [6].

Both SNLWIND and SNLWIND-3D were written in FORTRAN 77 and required recompilation for different grid densities and run lengths. This made using and supporting the programs difficult.

In January 2000, Neil Kelley removed all of the spectral models except the two defined by the IEC, and Marshall Buhl modernized the remaining code by rewriting all but the Fast Fourier Transform (FFT) routines in Fortran 95 and eliminating the C-preprocessor directives. Buhl's changes included using dynamic-memory allocation for the big arrays, which eliminated the need to recompile for different grid sizes and run lengths. He modified the input and output file format, streamlined processes, and added the ability to generate hub-height files in AeroDyn format. Because the changes were substantial, Buhl renamed the program SNwind (Sandia/NREL Wind) [7].

In 2003, NREL researchers updated the code to add results from the Lamar Low-Level Jet Project (LLLJP) and from the National Wind Technology Center (NWTC) Long-Term Inflow and Structural Testing (LIST) project. Bonnie Jonkman also added the spectral models from SNLWIND-3D that were removed from SNwind, and she replaced the FORTRAN 77 FFT routines with more modern routines from the Compaq Extended Math Library (CXML). Jonkman made changes to the Cholesky factorization algorithm, which sped up the code and allowed for a significant reduction in the memory required to run the program. She eliminated the requirement that the grid be an even number of points in each direction, and allowed the grid height to be different from its width. After these enhancements were in place, the code was modified to generate coherent structures with realistic temporal and spatial scaling, and coherent turbulence time-step files became another output option. The code was then renamed TurbSim (turbulence simulator) because of its ability to generate coherent turbulence.

In 2005, Bonnie Jonkman replaced the CXML FFT routines with routines from FFTPACK [8] so that TurbSim could be compiled on the Intel® Visual Fortran compiler. This made the code run much faster and also made it more portable. In 2009, Jonkman updated algorithms in the code to enable users to create much larger grids than were possible in earlier versions.

In 2012, Levi Kilcher added a new spectral model (TIDAL) to extend TurbSim's use for marine and hydrokinetic (MHK) energy. This model simulates turbulence in the water, and is *not* intended to be used for wind simulation.

Neil Kelley has written a companion document, *Overview of the TurbSim Stochastic Inflow Turbulence Simulator* [9], which discusses the development of TurbSim and includes some of the theory behind that development.

## Retrieving Files from the Archive

The TurbSim archive can be downloaded from the NREL Web server page at <http://wind.nrel.gov/designcodes/>. The downloaded file will have a name like "TurbSim\_v150.exe." Create a TurbSim folder somewhere on your file system and put this file there. You can double click on it from Windows Explorer or type "TurbSim\_v150" (or the exact

file name) at a command prompt, using the TurbSim folder as the current directory. Running this executable file creates some files and folders. Please see Marshall Buhl’s paper *Installing NWTC Design Codes* [10] for information on how to set up TurbSim to run in any folder.

To be able to generate coherent structures with TurbSim, users will also need to download the coherent structures archive from NREL’s Web server page. The file is named “TSM\_structures.exe.” Create a folder on your file system and put this file there. Execute the program by double clicking on it or by typing “TSM\_structures” at a command prompt with the folder you created as the current directory. When executed, this archive creates the files and folders used to define coherent structures. It is necessary to type the name of the path to these folders in TurbSim and AeroDyn input files.

## Distributed Files

The archive contains the TurbSim executable program for both 32- and 64-bit Windows® platforms. See Table 1 for a complete list of the files included in the TurbSim archive.

## Certification Test

Before using TurbSim for the first time, run the certification testing program. It is a batch file called “CertTest.bat” and is located in the “Test” folder. To test the installation, edit

**Table 1. Files in the TurbSim Archive**

File(s)	Description
ArcFiles.txt	The list of files that are written to the archive
Archive.bat	The batch file that creates the archive
ChangeLog.txt	The list of changes to TurbSim
Disclaimer.txt	The software disclaimer
RunTurbSim.pl	A sample Perl script used to run TurbSim, using a different seed each time
TurbSim.exe	The TurbSim program for 32-bit Windows® platforms
TurbSim64.exe	The TurbSim program for 64-bit Windows® platforms
TurbSim.inp	A sample input file
TurbSim_Hydro.inp	A sample input file with parameters set for the TIDAL model (for MHK use only)
TurbSim.pdf	The user’s guide in PDF format
TurbSim_AD.ctp	A sample AeroDyn coherent turbulence parameter input file
TurbSimOverview.pdf	Kelley & Jonkman’s overview of TurbSim, in PDF format [10]
Source\*.*	The Fortran source code for TurbSim
Test\*.*	Files used to run and manage the certification tests and MATLAB® scripts for reading TurbSim data
Test\EventData\*.*	Files used to run the certification tests with coherent turbulence
Test\TstFiles\*.*	NREL results for the certification tests

“CertTest.bat” and set the environment variables found near the top of the file to settings that are compatible with your system. You probably will have to change only the “Editor” variable. Then open a command window, go to the Test folder, and type “CertTest” or—if you have MATLAB® [11] installed on your computer and would like to see plots of the data—type “CertTest MATLAB.”

When the certification testing program is run, TurbSim executes several times. The test procedure compares the new results to those stored in the “Test\TstFiles” folder, and it writes the differences between the output files to a file called “CertTest.out.” If you have specified the “MATLAB” option, MATLAB opens and plots many results. It might be necessary to close the MATLAB program before the test procedure can continue. Before finishing, the test procedure automatically opens the “CertTest.out” file with the editor you specified with the “Editor” variable. Scan through the file; the only differences should be the date and time stamps in the headers of the files and the CPU time in the summary files. If you recompiled TurbSim with another compiler, some slight differences could appear in the last digit of many of the numbers.

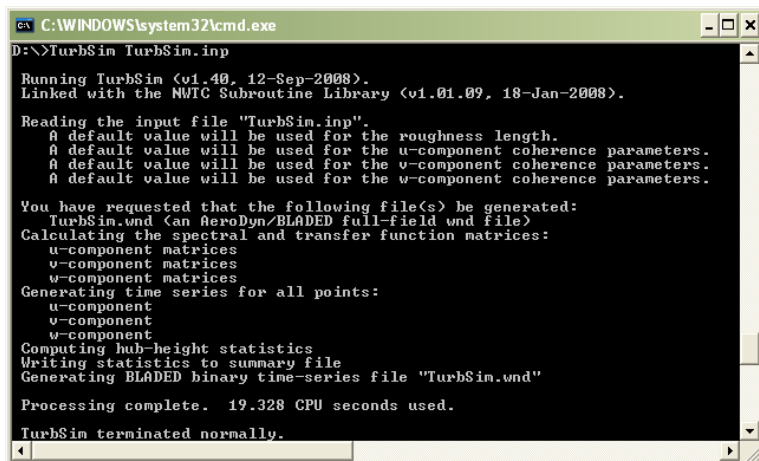
## Compiling TurbSim

It should not be necessary to compile TurbSim unless you want to make changes to the code or want to run TurbSim using a different operating system. The archive contains Fortran code specific to TurbSim. It also contains the Fortran FFTPACK version 4.1 [8], LAPACK version 3.0 [12], BLAS [13], [14], and RanLux [15] routines that TurbSim uses. Users must also download the NWTc Subroutine Library version 1.04.01, [16], which TurbSim uses. It can be found under Miscellaneous Software on the NREL Web server page at <http://wind.nrel.gov/designcodes/>.

The code has been written primarily for the Intel® Visual Fortran compiler. To port TurbSim to another platform or compiler, it might be necessary to make changes in the NWTc Subroutine Library’s SysVF.f90 file and possibly the BLAS LSAME() function. If you have access to an optimized BLAS library, you are encouraged to link your code with it instead of using the reference BLAS routines included in the TurbSim archive.

## Using TurbSim

To begin using TurbSim, a text input file is required. (Sample input files—which can be modified—are contained in the TurbSim archive and in Appendix A.) Next, to run TurbSim enter “turbsim [/h]



```
C:\WINDOWS\system32\cmd.exe
D:\>TurbSim TurbSim.inp

Running TurbSim (v1.40, 12-Sep-2008).
Linked with the NWTc Subroutine Library (v1.01.09, 18-Jan-2008).

Reading the input file "TurbSim.inp".
  A default value will be used for the roughness length.
  A default value will be used for the u-component coherence parameters.
  A default value will be used for the v-component coherence parameters.
  A default value will be used for the w-component coherence parameters.

You have requested that the following file(s) be generated:
  TurbSim.wnd (an AeroDyn/BLADED full-field wnd file)
Calculating the spectral and transfer function matrices:
  u-component matrices
  v-component matrices
  w-component matrices
Generating time series for all points:
  u-component
  v-component
  w-component
Computing hub-height statistics
Writing statistics to summary file
Generating BLADED binary time-series file "TurbSim.wnd"
Processing complete. 19.328 CPU seconds used.

TurbSim terminated normally.
```

Figure 2. Example TurbSim command line output

[<RootName.ext>]” at a command prompt; /h and <RootName.ext> are optional. The /h switch generates a help message, and <RootName.ext> is the name of the TurbSim input file. Following are two examples:

- `turbsim`  
 This starts TurbSim and opens the input file “turbsim.inp.” It is equivalent to entering “turbsim turbsim.inp.”
- `turbsim myroot.tsm`  
 This starts TurbSim and opens the input file “myroot.tsm.”

All output files have the specified root file name and different extensions.

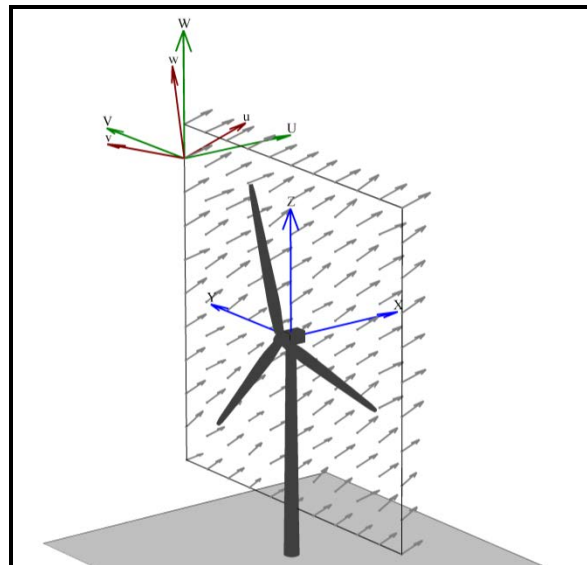
Wind components are defined in two separate coordinate systems as described in Table 2 and pictured in Figure 3. TurbSim computes winds in a coordinate system aligned with the direction of the mean velocity vector at each point in space. The velocities are rotated to the inertial reference frame coordinate system before they are written to output files. A quick-start guide for using the most basic turbulence is included in Appendix B.

## Input File

TurbSim reads a text input file to set the parameters required for the program to execute. The parameters are divided into several sections (discussed below). The heading for each parameter contains its name, a description, and the units for that parameter. The names of the parameters are provided for reference, but TurbSim does not read those names from the input file. Note that other programs or scripts that generate TurbSim input files, however, can and *do* use these parameter names.

**Table 2. Definitions of TurbSim Wind-Component Coordinate Systems**

Inertial Reference Frame	
$U$	Along positive $X$ (nominally downwind)
$V$	Along positive $Y$ (to the left when looking along $X$ )
$W$	Up, along positive $Z$ (opposite gravity)
Aligned with the Mean Wind	
$u$	Streamwise (longitudinal)
$v$	Transverse (crosswise)
$w$	Vertical



**Figure 3. Coordinates of a TurbSim wind field with 15° horizontal and 8° vertical mean flow angles**

TurbSim assumes that parameters are located on specific lines, so do not add or remove lines from the sample input files included in the archive. None of the parameters are case sensitive. The text of an example TurbSim input file is included in Appendix A of this guide.

## **Runtime Options**

The Runtime Options section initializes the pseudorandom number generator (pRNG) and tells TurbSim what type of output to generate. Appendix C contains a flow chart showing the function of the input parameters from this section. Users can choose any combination of output types listed in this section, but at least one output file must be generated to successfully run the code. The Output Files section of this guide provides more complete descriptions of these file types.

### ***RandSeed1: The First Random Seed [-]***

This input parameter is used in conjunction with the next parameter, *RandSeed2*; it tells TurbSim how to initialize the pRNG. This random seed must be an integer between  $-2147483648$  and  $2147483647$  (inclusive).

The random numbers generated by the pRNG are used to create random phases (one per frequency per grid point per wind component) for the velocity time series. When the pRNG is initialized in the same way (i.e., *RandSeed1* and *RandSeed2* are not changed), the user can reproduce the same random phases between runs, which is useful in comparing the effects of changes to other input parameters. Random numbers also are used to generate some default input values and the superimposed coherent structures for the non-IEC spectral models.

### ***RandSeed2: The Second Random Seed or pRNG to Use [-]***

This input parameter indicates which of three available pRNGs to use. This value is a second random seed or the strings “RNSNLW” or “RanLux.” Using RanLux is recommended because initial tests show that it seems to be the best behaved of the three generators.

If *RandSeed2* is a random seed, it must be an integer between  $-2147483648$  and  $2147483647$  (inclusive). TurbSim then uses the two seeds to initialize the intrinsic pRNG—which uses two separate congruential generators together to produce a period of about  $10^{18}$ . This intrinsic pRNG is based on an algorithm developed by Pierre L’ecuyer [17] and is identical to the one found in SNwind.

If *RandSeed2* is the string “RNSNLW,” TurbSim generates random numbers using the algorithm found in SNLWIND and SNLWIND-3D. It is initialized with only one seed.

If *RandSeed2* is the string “RanLux,” TurbSim uses Lüscher’s level 3 “Luxury Pseudorandom Numbers” [18], [19]. This pRNG is based on a subtract-and-borrow algorithm with a period on the order of about  $10^{171}$  and is modified by throwing numbers away to destroy correlations. This pRNG is initialized with only one seed.

### ***WrBHHTP: Write Binary Hub-Height Turbulence Parameters? [T/F]***

This parameter must be either “true” or “false.” Setting this output option to “true” generates a binary file with a “.bin” extension. The file contains time series of wind data and turbulence parameters from the center grid point at hub height (HH).



**WrFHHTP: Write Formatted Hub-Height Turbulence Parameters? [T/F]**

This “true” or “false” parameter is similar to the previous parameter, *WrBHHTP*. When set to “true,” it generates a file containing time series of wind data and turbulence parameters from the center grid point at hub height. This file is formatted (i.e., human-readable text) and has a “.dat” extension.

**WrADHH: Write AeroDyn hub-height files? [T/F]**

This “true” or “false” parameter provides an option to generate time series in the AeroDyn hub-height format. These files have an “.hh” extension.

**WrADFF: Write AeroDyn Full-Field Files? [T/F]**

This parameter must be either “true” or “false.” It provides the option to generate binary, full-field (FF) time series in a format designed to be read by AeroDyn. This format is unique to TurbSim and provides an encoding scheme designed to give maximum resolution. It contains all the information necessary to decode the time series in one file, but it is not compatible with GH Bladed. This file format will be supported in AeroDyn v12.60 and later versions. Continue to use the Bladed-compatible FF files (parameter *WrBLFF*) with all other AeroDyn versions. These files have a “.bts” extension.

**WrBLFF: Write Bladed-Style Full-Field Files? [T/F]**

Like the *WrADFF* parameter, the *WrBLFF* “true” or “false” parameter also provides the option to generate binary, full-field (FF) time series in a format designed to be read by AeroDyn. This format is compatible with GH Bladed, but in some cases the encoding scheme provides less resolution than the files generated by *WrADFF*. These files have a “.wnd” extension.

**WrADTWR: Generate AeroDyn Tower Points? [T/F]**

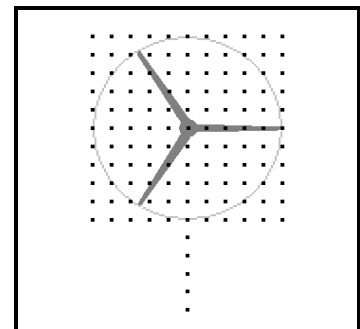
The *WrADTWR* “true” or “false” parameter determines whether TurbSim generates binary tower time series, which contain points in a line at the tower centerline from the bottom of the rectangular grid to the ground. Figure 4 shows an example of the location of tower points. If a user chooses to output FF time series in the format unique to TurbSim using *WrADFF* (“.bts” files), these tower points are added to the FF binary output file. Otherwise, a separate tower-points binary file is created using an encoding scheme similar to the Bladed-style FF file format used in the “.wnd” files (generated with parameter *WRBLFF*). This extra binary file for the tower points has a “.twr” extension.

**WrFMFFF: Write Formatted Full-Field Files? [T/F]**

This “true” or “false” output option determines whether TurbSim generates FF time series in SNLWIND-3D human-readable format. One file is generated for each wind component, and the three files have extensions “.u,” “.v,” and “.w,” respectively. Please note that AeroDyn cannot read these text files.

**WrACT: Write Coherent Turbulence Files? [T/F]**

This “true” or “false” parameter indicates whether coherent turbulence should be generated, creating time-step files in AeroDyn format. The coherent turbulence feature is not available with the IEC or TIDAL spectral models. For the other spectral models, the feature is available only when the gradient Richardson number (input



**Figure 4. Example of tower points below a rectangular grid**

parameter *RICH\_NO*) is greater than  $-0.05$ . The mean wind speed at the top of the coherent structure also must be greater than the mean wind speed at the bottom of the coherent structure. The Coherent Turbulence Scaling Parameters section of the input file discusses how to set the coherent structure location.

The coherent turbulence time-step files, which have a “.cts” extension, are intended to be superimposed on background FF turbulence files. As a result, TurbSim also creates binary FF time series (*WrBLFF* or *WrADFF*) when a coherent turbulence time-step file is requested. If no FF time series format has been specified, TurbSim creates a GH Bladed-style binary FF file (*WrBLFF* “.wnd” file). For more information on using these “.cts” files, see the Using Coherent Turbulence Time-Step Files with AeroDyn section in this guide.

### ***Clockwise: Does the Turbine Rotate Clockwise? [T/F]***

This true” or “false” parameter is a flag to indicate whether the turbine rotates in a clockwise direction when looking downwind. This feature determines the order in which the horizontal grid points of the Bladed-style FF files are written (the parameter *WrBLFF* must be “true”). Because AeroDyn also reads the Bladed-style FF files based on the direction of rotation, this flag does not affect the results when used with AeroDyn. This parameter probably is useful only for comparing FF results between Bladed and AeroDyn.

### ***ScaleIEC: Scale IEC Turbulence to Exact Standard Deviations? [0, 1, or 2]***

The *ScaleIEC* parameter is a switch to tell how to scale the time-domain velocity output of the IEC spectral models and is applicable to only the IECKAI and IECVKM spectral models. For numerical reasons, the turbulence intensity (TI) of the IEC spectral models—without this scaling—usually is slightly less than the specified value. Increasing the time series length and/or decreasing the size of the time step results in values closer to the specified TI. Different random seeds produce a Gaussian distribution of TI in the longitudinal wind component, due to the spatial coherence. To get the exact specified value of TI, the time series are multiplied by a scaling factor determined by the ratio of the target to the actual calculated standard deviation.

When *ScaleIEC* is set to “0,” no scaling takes place in the time domain. The result is the variation in TI discussed above. When the *ScaleIEC* switch has a value of “1,” the time series at each simulated point use the same scaling factor with a different factor for each wind component. Those three scaling factors (one each for *u*, *v*, and *w*) are determined so that the standard deviations in wind speed (and thus TI) at the hub point are the exact value specified for the *AnalysisTime*-length time series that is generated. The TI at the other simulated points will vary. When *ScaleIEC* is “2,” the time series at each simulated point in space is scaled independently (i.e., each point and each component has its own scaling factor) so that the TI is the exact specified value at *each* point. This scaling method alters the coherence between points. Table 3 summarizes the valid input values.

### **Turbine/Model Specifications**

The Turbine/Model Specifications section of the TurbSim input file determines the size and shape of the grid where time series is generated. It also determines the time/frequency content of the resulting time series and sets the mean flow angles. Appendix C contains a flow chart showing the function of the input parameters from this section.

**Table 3. Valid Scale/EC Values**

Input Value	Description
0	No scaling: time series will remain as generated.
1	Scaling by HH value: all time series will be modified, using the same scaling factor for each point (each component has separate scale). The hub point will have the exact specified TI; other points will not.
2	Independent scaling: all time series will be modified independently; scaling factors vary by point and component. Each point will have the exact specified TI.

***NumGrid\_Z: Number of Vertical Grid Points [-]***

This input parameter is the number of grid points to generate in the vertical direction. It must be an integer greater than 1. Unlike SNwind, which accepted only even numbers, TurbSim allows both even and odd grid-point sizes. TurbSim always generates a point at the hub, regardless of where the other grid points are located. (Note that this “extra” hub point is not contained in the binary FF files generated when *WrBLFF* or *WrADFF* are set.)

***NumGrid\_Y: Number of Horizontal Grid Points [-]***

This parameter indicates the number of grid points in the horizontal direction, and it must be an integer greater than 1. If *NumGrid\_Y* is an odd number, points fall along the undeflected tower centerline.

***TimeStep: Time Step [s]***

The *TimeStep* parameter is the time step in seconds (i.e.,  $\Delta t$ ). It is set to 0.05 seconds in the sample input files, and that value is recommended for most simulations. The time step determines the maximum frequency,  $f_{\max}$ , used in the inverse FFT:

$$f_{\max} = 1/\Delta t. \quad (1)$$

***AnalysisTime: Length of Analysis [s]***

The *AnalysisTime* parameter is the length in seconds of the data to be analyzed (i.e.,  $t_{\max}$ ). This number dictates the frequencies which are used to generate the output time series. The following equations relate *AnalysisTime* to the frequency,  $f$ , and the number of frequencies, *NumFreq*:

$$\Delta f = \frac{1}{AnalysisTime} \quad (2)$$

$$NumFreq = \frac{AnalysisTime}{TimeStep} \quad (3)$$

It is recommended that *AnalysisTime* be at least 600 seconds. To speed up the inverse FFT computations, TurbSim might add a few extra time steps to ensure that the number of analysis time steps is a product of small prime numbers. Extra time steps also are added if the length of the output time series is less than the *AnalysisTime* (see the discussion of the *UsableTime* parameter below).

**UsableTime: Usable Time Series Length [s]**

This parameter is the usable length (in seconds) of the data to output. This number differs slightly from the actual amount of data that TurbSim outputs. Because AeroDyn requires that there be data both upwind and downwind of the tower in case the turbine is yawed, it mandates that there be extra data in the FF files to shift the data enough to ensure that the turbine resides entirely within the wind-data domain. TurbSim always adds the amount of time equal to the grid width divided by the mean HH wind speed,  $\bar{u}_{hub}$ , to the requested amount of usable time:

$$OutputTime = UsableTime + \frac{GridWidth}{\bar{u}_{hub}} . \tag{4}$$

The analysis time must be at least as large as the output time:

$$AnalysisTime \geq OutputTime . \tag{5}$$

If necessary, TurbSim increases *AnalysisTime* to satisfy this relationship.

**HubHt: Turbine Hub Height [m]**

The *HubHt* parameter is hub height of the turbine for which the inflow is being generated. TurbSim uses the metric system so enter the value in meters. This parameter is used as a reference height for determining the grid location.

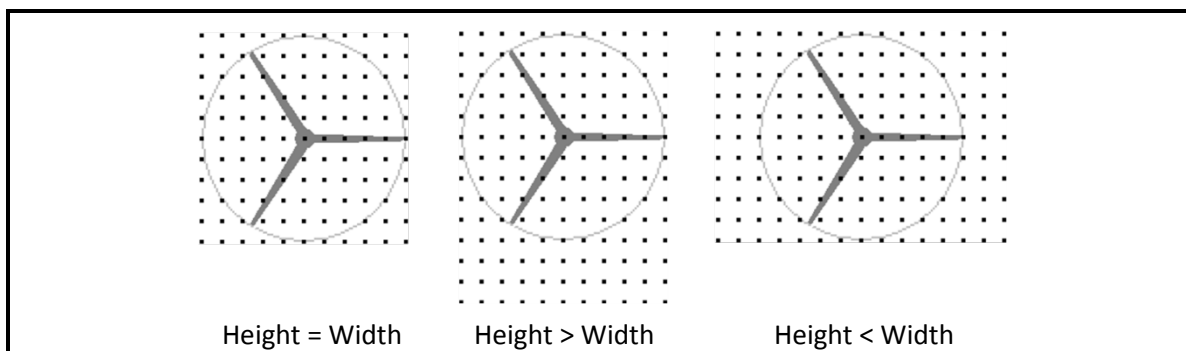
**GridHeight: Height of the Grid [m]**

This parameter is the distance (in meters) between the top and bottom of the grid. The top of the grid is assumed to be aligned with the top of the rotor disk (see Figure 5), and because all points of the grid must be above ground level,  $\frac{1}{2}GridHeight < HubHt$ .

When choosing a value for *GridHeight*, keep in mind that AeroDyn does not allow any part of the blade—including all system displacements—to lie outside the FF grid. The grid height must be large enough to encompass the entire rotor disk of FF files. See the parameter *GridWidth* for further discussion.

**GridWidth: Width of the Grid [m]**

This parameter is the width of the grid in meters. The rotor is assumed to be centered



**Figure 5. Example grid and rotor placements: the circles pictured here are the rotor diameters assumed by TurbSim; the actual rotor diameter(s) will be smaller than pictured**

horizontally on the grid. If you are generating FF files for AeroDyn, the grid width—like the height—must be large enough to ensure that no part of the blade lies outside the grid, even when the system is displaced.

TurbSim assumes that the diameter of the rotor disk is the smaller of the *GridHeight* and *GridWidth* values. Because AeroDyn must interpolate within the grid for any point at which it needs wind speeds (i.e., AeroDyn cannot extrapolate), *GridHeight* and *GridWidth* should be larger than the rotor diameter. In fact, AeroDyn warns users if the grid width and height are not at least 10% larger than the rotor diameter. For turbines that move a lot during simulation (e.g., floating wind turbines), the grid might have to be even larger.

As pictured in Figure 5, the hub is in the horizontal center of the grid, and the turbine hub height plus assumed rotor radius determines the top of the grid.

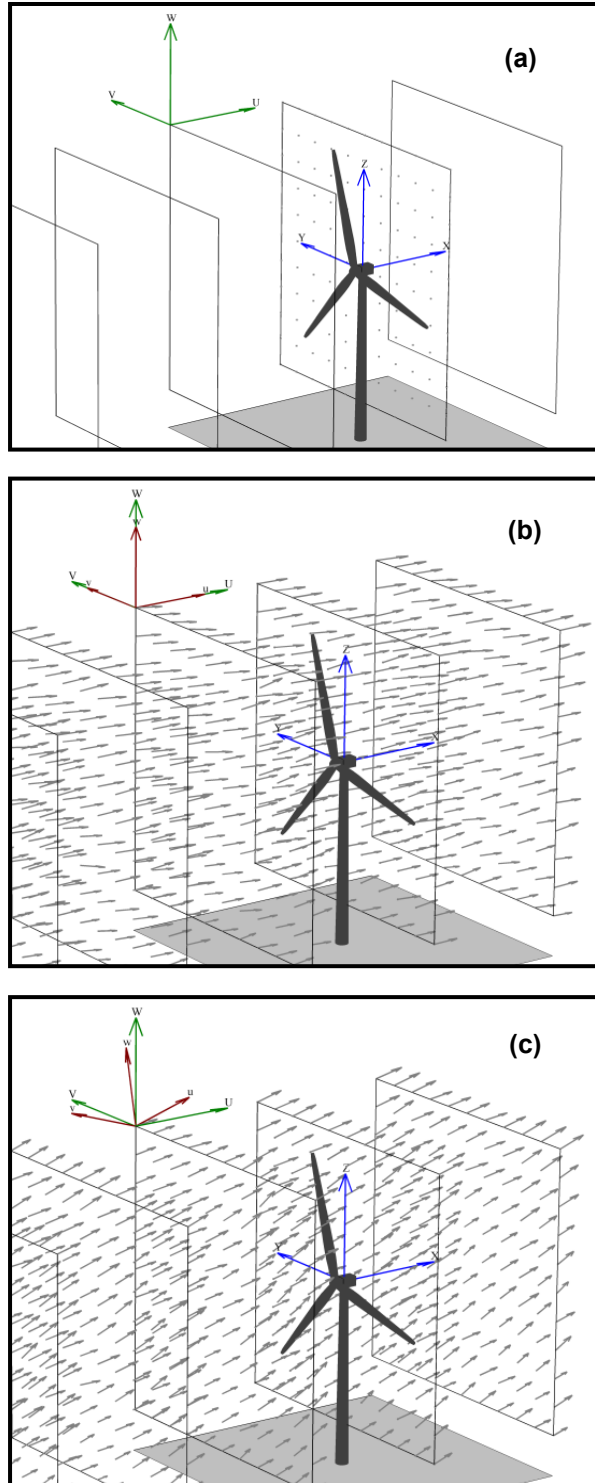
***VFlowAng*: Mean Vertical Flow Angle [°]**

This parameter is the mean vertical angle of the wind, which is constant across the entire grid. Enter the angle in degrees, and do not exceed 45° in magnitude. A positive value means that the wind is blowing uphill; a negative value indicates that the wind is blowing downhill. See *HFlowAng* and Figure 6 for more details.

***HFlowAng*: Mean Horizontal Flow Angle [°]**

This parameter is the mean horizontal (crosswise) angle of the wind in degrees. In all cases except the GP\_LLJ model, the horizontal flow angle is constant across the entire grid. For the GP\_LLJ model, which introduces direction shear with height, *HFlowAng* is the horizontal angle at hub height.

The mean flow angles *VFlowAng* and *HFlowAng* are used to rotate the wind from its alignment with the mean flow to the inertial reference frame. Users should be cautious,



**Figure 6. Example of TurbSim grids as implemented in AeroDyn: (a) The inertial frame coordinate systems and planes “marching” along positive X, regardless of flow angles, (b) wind field with both flow angles 0°, (c) the same wind field with *VFlowAng* = 8° and *HFlowAng* = 15°**

however, because AeroDyn—in its implementation of Taylor’s frozen turbulence hypothesis—marches FF grids through the turbine along the positive  $X$  axis at the mean hub-height wind speed, without regard to the flow angles (see Figure 6). This could give strange results if the mean flow angles are not small (for example, if  $HFlowAng = 180^\circ$ , the grids move through the turbine in the opposite direction the wind is blowing). We recommend using a yaw error in the turbine simulation rather than using the  $HFlowAng$  parameter and using only small angles (e.g., less than  $10^\circ$ ) for  $VFlowAng$ .

### Meteorological Boundary Conditions

The Meteorological Boundary Conditions section of the TurbSim input file sets the spectral model to simulate, determines the mean wind speeds, and sets the boundary conditions for the spectral models defined in the IEC standards. Appendix C contains flow charts showing the function of the input parameters from this section.

#### ***TurbModel: Turbulence Model [-]***

The *TurbModel* parameter tells TurbSim which spectral model it should use. Enter the six-character input value of the desired spectral model. Valid values are found in Table 4. For more information on these models, see the Spectral Models section in this document.

#### ***IECstandard: IEC Standard [-]***

This input parameter tells TurbSim which IEC standard to use. Enter “1” to use the scaling from the IEC 61400-1 [20] standard or enter “2” or “3” to use the scaling from the IEC 61400-2 (small wind turbine) [21] or -3 (offshore wind turbine) [22] standards. To use the scaling parameters from the second edition of the IEC 61400-1 standard [23], follow the input with the string “-ED2” (i.e., “1-ED2”). Likewise, to use the scaling parameters from IEC 61400-1, 3<sup>rd</sup> ed. [20], input the string “1-ED3”. If the 61400-1 edition number is not specified, TurbSim uses the scaling from the third edition of IEC 61400-1 for the Kaimal model and scaling from the standard’s second edition for the von Karman model (which is not defined in the newer edition). This input parameter is used only if the spectral model is IECKAI or IECVKM.

**Table 4. Valid TurbSim Spectral Models**

<b><i>TurbModel</i> Input Value</b>	<b>Description</b>
GP_LLJ	NREL Great Plains low-level jet
IECKAI	IEC Kaimal
IECVKM	IEC von Karman
NWTCUP	NREL National Wind Technology Center
SMOOTH	Risø smooth terrain
WF_07D	NREL wind farm: 7 rotor-diameters downwind
WF_14D	NREL wind farm: 14 rotor-diameters downwind
WF_UPW	NREL wind farm: upwind
TIDAL	Tidal channel turbulence model (water)

### ***IEC*turbc: IEC Turbulence [%]**

The *IEC*turbc parameter tells TurbSim what turbulence intensity you want to use with the IEC Kaimal or von Karman spectral models. Input values of “A,” “B,” or “C” correspond to the standard IEC categories of turbulence characteristics, with “A” being the most turbulent. Figure 7 contains the relationship between wind speed and standard deviation for the standard IEC categories and turbulence types. You can also specify the TI in percent instead of choosing the turbulence categories. In this case, the standard deviation of the longitudinal wind speed,  $\sigma_1$ , is calculated using the following equation:

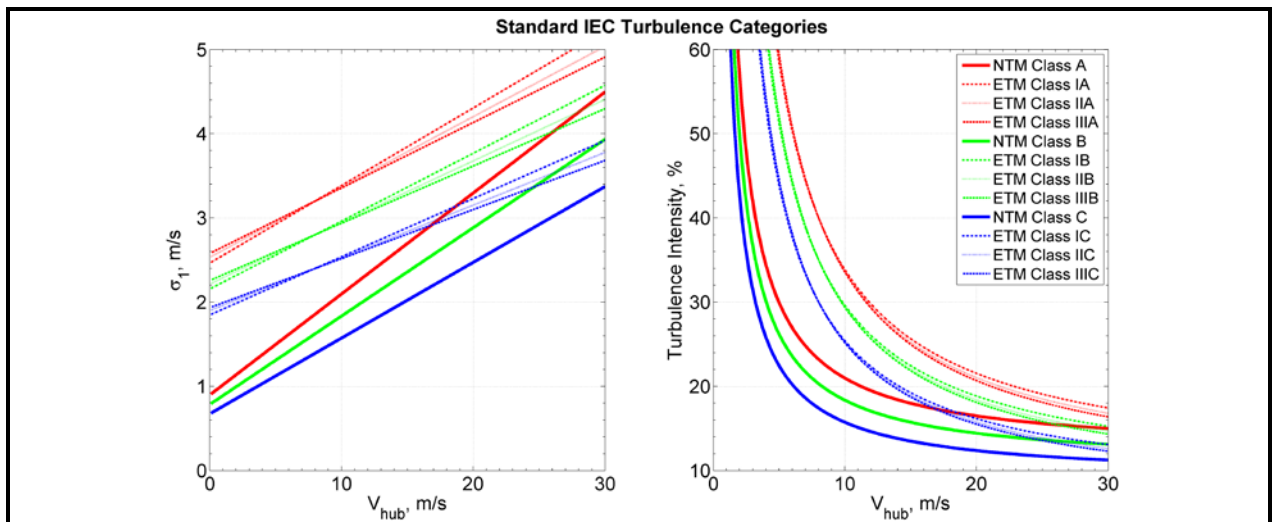
$$\sigma_1 = \frac{IEC_{turbc} -}{100} u_{hub} . \quad (6)$$

If you use the NWTcup spectral model and enter the string “KHTEST” for the *IEC*turbc parameter, TurbSim creates a test wind field that can be used to see the effects of a KH billow. With this test function, TurbSim overrides the inputs for Richardson number (0.02); power-law coefficient (0.3); and billow type, size, and location. An LES-type billow centered on the rotor disk is scaled so that the billow achieves a bandwidth of at least 25 Hz and so that the expected maximum coherent turbulent kinetic energy (CTKE), defined as

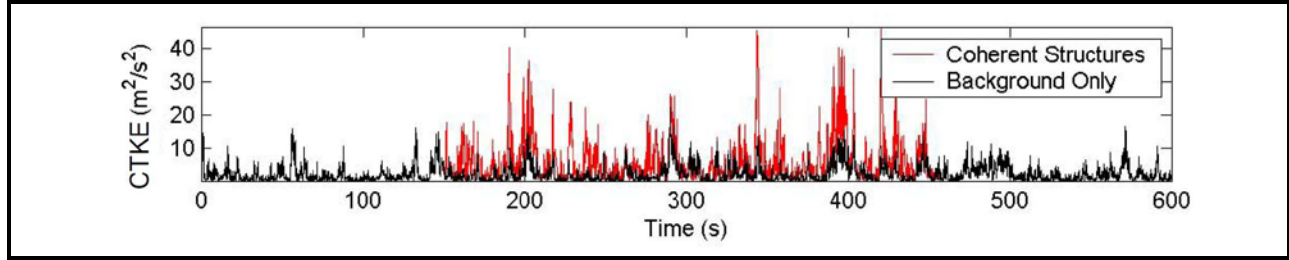
$$CTKE = \frac{1}{2} \sqrt{(u'w')^2 + (u'v')^2 + (v'w')^2} , \quad (7)$$

is at least  $30 \text{ m}^2/\text{s}^2$ . This billow lasts at least half of the usable length of the output time series, and starts a quarter of the way through the time series. An example of KHTEST is presented in Figure 8.

The *IEC*turbc parameter is not used for any other spectral model.



**Figure 7. Longitudinal wind-speed standard deviation and TI for IEC turbulence categories as functions of the mean hub-height wind speed,  $V_{hub}$**



**Figure 8. Coherent turbulent kinetic energy (CTKE) of an example simulation using KHTEST: the coherent structure placement in the middle of the time series is shown by the red lines**

***IEC\_WindType: IEC Turbulence Model [-]***

This parameter indicates which IEC wind model will be used. Valid entries, which are found in Table 5, include the Normal Turbulence Model (NTM), Extreme Turbulence Model (ETM), and Extreme Wind Speed Model (EWM) using the 10-minute average wind speed with a recurrence period of 1 year or 50 years. Note that the EWM scaling parameters in TurbSim are valid only for 10-minute simulations. The definitions of these models and of the wind turbine classes can be found in the IEC 61400-1 standard (3<sup>rd</sup> ed.) [20]. If the *IECturbc* parameter was specified as a percentage instead of as a standard turbulence category, the wind model must be “NTM.” This input is used only with the IEC spectral models.

***ETMc: Extreme Turbulence Model Parameter c [m/s]***

The *ETMc* input parameter is the value of the variable *c* in the equation for the longitudinal component standard deviation,  $\sigma_1$ , in the ETM (see Eq. 19 in section 6.3.2.3 of IEC 61400-1 3<sup>rd</sup> ed. [20]):

$$\sigma_1 = c I_{ref} \left( 0.072 \left( \frac{V_{ave}}{c} + 3 \right) \left( \frac{\bar{u}_{hub}}{c} - 4 \right) + 10 \right). \quad (8)$$

**Table 5. Valid IEC Turbulence Models**

<b><i>IEC_WindType</i></b>	<b>Description</b>
NTM	Normal Turbulence Model
1ETM	Class I Extreme Turbulence Model
2ETM	Class II Extreme Turbulence Model
3ETM	Class III Extreme Turbulence Model
1EWM1	Class I turbulent Extreme Wind Speed Model, 1-yr recurrence
2EWM1	Class II turbulent Extreme Wind Speed Model, 1-yr recurrence
3EWM1	Class III turbulent Extreme Wind Speed Model, 1-yr recurrence
1EWM50	Class I turbulent Extreme Wind Speed Model, 50-yr recurrence
2EWM50	Class II turbulent Extreme Wind Speed Model, 50-yr recurrence
3EWM50	Class III turbulent Extreme Wind Speed Model, 50-yr recurrence



The values for the variables  $I_{ref}$  and  $V_{ave}$ —defined respectively as the expected value of turbulence intensity and 20% of the reference wind-speed average—are determined by the wind turbine class. Enter a value for  $c$  in meters per second, or enter “default” for TurbSim to use  $c = 2$  m/s, as defined in the standard. This parameter is used only with the Extreme Turbulence Model (i.e., when  $IEC\_WindType = xETM$ ).

**WindProfileType: Type of Wind Profile [-]**

The *WindProfileType* parameter tells TurbSim how to calculate the mean wind profile. Valid entries are found in Table 6. Users can enter the string “default” here for TurbSim to pick a wind profile based on the spectral model. The GP\_LLJ model defaults to the JET profile and all others default to the IEC profile. Please see the Wind (Velocity) Profiles section of this guide for more details about the different wind profile types. The “H2L” velocity profile should always be used with, and only with, the TIDAL spectral model.

**RefHt: Reference Height [m]**

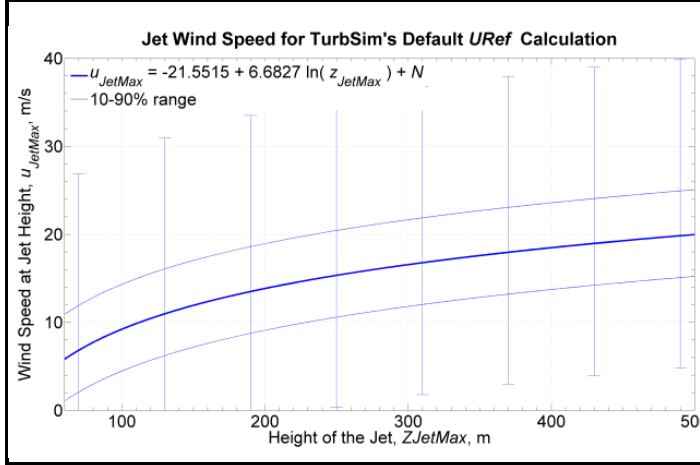
The *RefHt* parameter specifies the height (in meters) of the corresponding reference wind speed (parameter *URef*). This parameter enables users to specify the mean wind speed at a height other than the hub height. TurbSim uses this reference height and wind speed with the wind profile type to calculate the HH mean wind speed. The reference height also is used with *URef* and the surface roughness (parameter *Z0*) to compute default input values for parameters *UStar* and *ZI*.

**URef: Reference Wind Speed [m/s]**

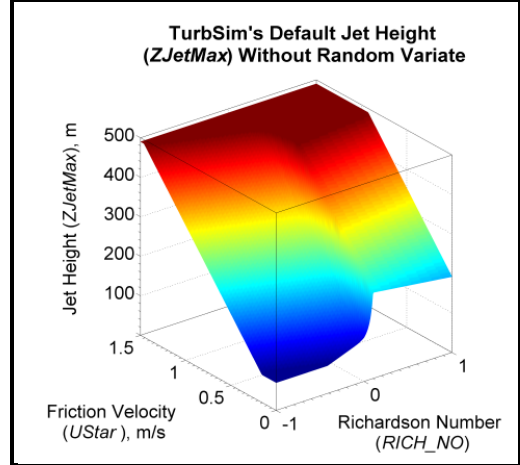
The *URef* parameter is the mean streamwise wind speed at the reference height. It is the mean value over the entire *AnalysisTime* length of the simulation of the *u*-component wind speed. It must be a positive value in units of meters per second. If you use “JET” for the *WindProfileType* parameter, you can enter the string “default” here for TurbSim to calculate a default wind speed in two steps: (1) TurbSim calculates the maximum speed of the jet wind profile,  $\bar{u}_{JetMax}$ , based on the jet height, *ZJetMax*, and a random variate (shown in Figure 9) then (2) it calculates the wind speed at *RefHt* using  $\bar{u}_{JetMax}$  along with parameters *ZJetMax*, *RICH\_NO*, and *UStar*. The calculations of the low-level jet wind speed profile are discussed further in the Wind (Velocity) Profiles section of this guide.

**Table 6. Valid Wind Profile Types**

<i>WindProfileType</i>	Description
PL	Power-law wind profile
LOG	Diabatic (logarithmic) wind profile; not valid with KHTEST
H2L	Logarithmic velocity profile for MHK models (TIDAL)
JET	Low-level jet wind profile, valid only with GP_LLJ model
IEC	Power-law profile on the rotor disk; logarithmic profile elsewhere
Default	Uses a default: JET for the GP_LLJ model; H2L for the TIDAL model; IEC for all other models



**Figure 9. Default jet wind speed for  $U_{Ref}$  calculation: error bars indicate the range of random variate,  $N$ ; dotted lines mark the tenth and ninetieth percentiles**



**Figure 10. Default jet height,  $Z_{JetMax}$ , without random variates (the random variation range is approximately  $\pm 50$  m)**

### **$Z_{JetMax}$ : Height of the Jet [m]**

The  $Z_{JetMax}$  parameter is the height in meters of the low-level jet. Enter the approximate height at which the low-level jet wind profile reaches its maximum wind speed, or enter the string “default” to have TurbSim calculate a jet height. The default height is a function of parameters  $RICH\_NO$  and  $U_{star}$  with a random component based on LLLJP measurements. The default height—without the random component—is plotted in Figure 10.  $Z_{JetMax}$ , which must be a value between 70 m and 490 m, is used to calculate the mean wind speed and direction profiles. It is used only when  $WindProfileType$  is “JET.”

### **$PL_{Exp}$ : Power-Law Exponent [-]**

The  $PL_{Exp}$  parameter is used to compute the mean  $u$ -component wind speeds across the rotor disk when  $WindProfileType$  is “IEC” or “PL.” It is the exponent used to define the power-law wind profile,

$$\bar{u}(z) = \bar{u}_{hub} \left( \frac{z}{HubHt} \right)^{PL_{Exp}}, \quad (9)$$

where  $z$  is the height above ground level. The exponent can be positive, negative, or zero (for no shear). Enter the string “default” to have TurbSim use a default value based on the specified spectral model, as shown in Table 7. If  $KHTEST$  is specified for parameter  $IEC_{turbc}$ , the  $PL_{Exp}$  parameter is overwritten to 0.3.

### **$Z_0$ : Surface Roughness Length [m]**

The surface roughness length,  $Z_0$ , is the last parameter in this section. This length—a measure of the roughness of the surface terrain—is the extrapolated height at which the mean wind speed becomes zero in a neutral atmosphere, assuming a logarithmic vertical wind profile:

$$\bar{u}(z) = U_{Ref} \frac{\ln(z/z_0)}{\ln(RefHt/z_0)}. \quad (10)$$

**Table 7. Default Inputs for Meteorological Boundary Conditions**

<i>TurbModel</i>	<i>PLExp</i>	<i>Z0</i> (m)
IECKAI, IECVKM	0.11 for EWM 0.14 for offshore (61400-3) NTM, 0.2 otherwise	0.03
SMOOTH	0.143	0.01
GP_LLJ	0.143	0.005
NWTCUP	0.08-0.15, increasing with <i>RICH_NO</i> , 0.3 for KHTEST option	0.021
WF_UPW	same as NWTCUP	0.018
WF_07D	0.13-0.18, increasing with <i>RICH_NO</i>	0.064
WF_14D	same as WF_07D	0.233

Enter the length in meters, or enter the string “default” to have TurbSim use a default value based on the specified spectral model. The default values are listed in Table 7. This parameter is not used for the TIDAL spectral model.

### Non-IEC Meteorological Boundary Conditions

If you have specified either the Kaimal or von Karman spectral model, TurbSim does not read this section of the input file. The other (non-IEC) spectral models require the additional meteorological boundary conditions contained in this section. All of the inputs in this section, with the exception of the gradient Richardson number, can be replaced with the string “default.” Appendix C contains flow charts showing the function of the input parameters from this section and how the default values are chosen.

#### **Latitude: Site Latitude [°]**

The first parameter in this section is the site latitude in degrees. The latitude is used only to calculate a Coriolis term in the default mixing layer depth (parameter *ZI*). The magnitude of the latitude must be between 5° and 90°; the default value is 45°.

#### **RICH\_NO: Gradient Richardson Number [-]**

The *RICH\_NO* parameter is the turbine-layer vertical stability given by the dimensionless gradient Richardson number, which is defined as

$$RICH\_NO = \frac{\frac{g}{\theta} \frac{\partial \bar{\theta}}{\partial z}}{\left( \frac{\partial \bar{u}}{\partial z} \right)^2}. \quad (11)$$

In this equation, *g* is the gravitational acceleration, *z* is the height above ground, and *u* is the wind speed. The variable  $\theta$  represents potential temperature, which is calculated using the mean absolute air temperature, *T*, and atmospheric pressure, *p*:

$$\theta = T \left( \frac{1000}{p} \right)^{0.286} . \quad (12)$$

The *RICH\_NO* parameter is used to calculate the velocity spectra and the JET and LOG wind profiles, scale coherent structures, and determine default values for many input parameters.

Enter zero for neutral conditions, a negative value for unstable conditions, or a positive number for stable atmospheric conditions. The GP\_LLJ and NWTCUP models limit this input to  $-1 \leq RICH\_NO \leq 1$ . If KHTEST is specified for parameter *IECturbc*, the *RICH\_NO* parameter is overwritten to 0.02. The *RICH\_NO* parameter does not accept the value “default.” The *RICH\_NO* parameter is not used for the TIDAL spectral model.

### ***UStar: Rotor-Disk Average Friction Velocity [m/s]***

The parameter *UStar* is the friction or shear velocity,  $u_*$ , averaged over the rotor disk:

$$\begin{aligned} UStar &= \overline{u_*} \\ &= \frac{1}{n_p} \sum_{i=1}^{n_p} \sqrt{|u'w'|_i} , \end{aligned} \quad (13)$$

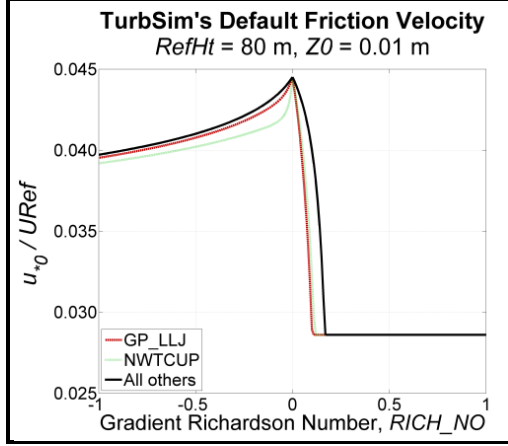
where the prime quantities indicate the fluctuating (zero-mean) longitudinal ( $u$ ) and vertical ( $w$ ) wind components at  $n_p$  measurement points on the rotor disk. The GP\_LLJ model, which scales the velocity spectra with *local* friction velocities ( $u_*$  values varying with height), assumes that *UStar* is the average friction velocity of three points on the  $u_*$  profile: one at the hub, one at the top of the rotor, and one at the bottom of the rotor.

*UStar* is used to scale the velocity spectra of non-IEC spectral models, to scale the JET and H2L mean velocity profiles, and to calculate the default values of many input parameters. Enter *UStar* in units of meters per second or enter “default” to have TurbSim calculate an appropriate value. The default value for the TIDAL model is  $UStar = 0.05 URef$ . For non-hydro spectral models (i.e., all but TIDAL), the default value is calculated using the diabatic  $u_{*0}$  (near the surface), which is predicted by Panofsky and Dutton’s modified logarithmic profile [24] using

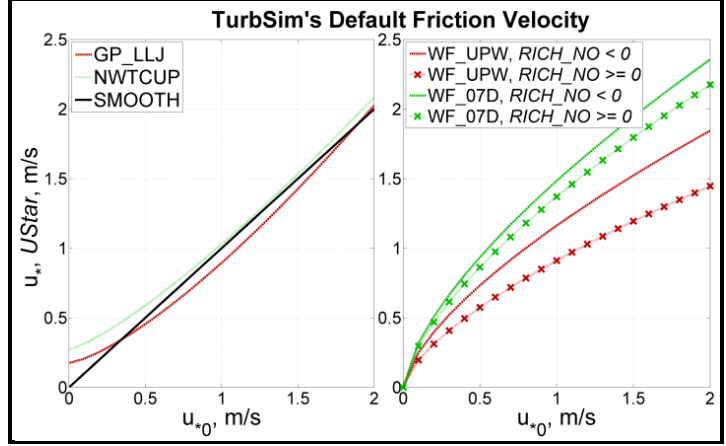
$$u_{*0} = \frac{0.4 URef}{\ln\left(\frac{RefHt}{Z0}\right) - \Psi_M(RICH\_NO)} , \quad (14)$$

where  $\Psi_M$  is a function that depends on the *RICH\_NO* stability parameter. The relationship between *RICH\_NO* and  $u_{*0}$ , normalized by *URef*, at *RefHt* = 80 m is plotted in Figure 11. The relationship between  $u_{*0}$  and the default *Ustar* is shown in Figure 12.

If “default” is entered for the reference wind speed, *Uref*, the string “default” *cannot* be entered for the *UStar* parameter, because the default values for the two parameters are interdependent.



**Figure 11. Diabatic friction velocity,  $u_{*0}$ , normalized by  $U_{Ref}$  and calculated using  $RefHt = 80$  m and  $Z0 = 0.01$  m**



**Figure 12. Default  $U_{Star}$  as a function of diabatic friction velocity,  $u_{*0}$  (left: SMOOTH, GP\_LLJ, and NWTcup models, right: wind farm models)**

### **ZI: Depth of the Mixing Layer [m]**

The parameter  $ZI$  is the depth of the mixing layer (in meters). This parameter scales the velocity spectra in unstable atmospheric conditions and is not used for stable atmospheric conditions. The default mixing layer depth is calculated using

$$ZI = \begin{cases} \frac{400U_{Ref}}{\log_{10}\left(\frac{RefHt}{Z0}\right)}, & U_{Star} < u_{*0} \\ \frac{U_{Star}}{12.0\omega \sin\left(\frac{\pi}{180}|Latitude|\right)}, & U_{Star} \geq u_{*0}, \end{cases} \quad (15)$$

where  $\omega = 7.292116 \times 10^{-5}$  rad/s is the Earth's angular speed of rotation. This equation combines the work of Dutton et al. [25] with the ESDU [26]. This parameter is not used for the TIDAL spectral model.

### **PC\_UW: Average $u'w'$ Reynolds Stress at the Hub [ $m^2/s^2$ ]**

The  $PC_{UW}$  parameter is the desired average  $u'w'$  Reynolds stress (in  $m^2/s^2$ ) at the simulated hub point. It is used in conjunction with the next two inputs, parameters  $PC_{UV}$  and  $PC_{VW}$ , to create some correlation between the wind-speed components.

TurbSim modifies the  $v$ - and  $w$ -component wind speeds (for non-IEC models only) by computing a linear combination of the time series of the three independent wind-speed components to obtain the mean Reynolds stresses  $PC_{UW}$ ,  $PC_{UV}$ , and  $PC_{VW}$  at the hub point. The linear combinations are computed for each point,  $j$ , using the equations

$$\begin{aligned} u'_{j,correlated} &= u'_{j,independent} \\ v'_{j,correlated} &= \alpha_{uv} u'_{j,independent} + v'_{j,independent} + \alpha_{vw} w'_{j,independent} \\ w'_{j,correlated} &= \alpha_{uw} u'_{j,independent} + w'_{j,independent} \end{aligned} \quad (16)$$

The three  $\alpha$  variables are coefficients chosen to generate the desired Reynolds stresses for the correlated wind components at the hub:

$$\begin{aligned} PC\_UW &= \overline{u'_{hub,correlated} w'_{hub,correlated}} \\ PC\_UV &= \overline{u'_{hub,correlated} v'_{hub,correlated}} \\ PC\_VW &= \overline{v'_{hub,correlated} w'_{hub,correlated}} \end{aligned} \quad (17)$$

Because this method affects the frequency domain somewhat, we have placed the following limit on the coefficients:  $|\alpha| \leq 1$ . This limit can cause the actual hub Reynolds stresses to differ from the desired values.

Enter the string “default” for TurbSim to compute an appropriate Reynolds stress for  $PC\_UW$ . The default value for the TIDAL model is  $PC\_UW = -UStar^2 (1 - HubHt/RefHt)$ . The default value for the SMOOTH model is the same as that for the WF\_UPW and WF\_07D models:  $PC\_UW = -UStar^2$ . The default value for the WF\_14D model has the same magnitude as the SMOOTH model, but is positive 1% of the time (randomly). The magnitudes of the defaults for the NWTCUP and GP\_LLJ models are functions of  $UStar$ ,  $RICH\_NO$ , height, mean hub-height wind speed, and shear across the rotor disk. The signs of the defaults are determined randomly, with the probability that  $PC\_UW$  is negative increasing with the magnitude of the default. Users can also enter the string “none” to set  $\alpha_{uw} = 0$  and disable the correlation between the  $u$  and  $w$  components.

### **$PC\_UV$ : Average $u'v'$ Reynolds Stress at the Hub [ $m^2/s^2$ ]**

The  $PC\_UV$  parameter is the desired average  $u'v'$  Reynolds stress (in  $m^2/s^2$ ) at the simulated hub point. It is used in conjunction with the parameters  $PC\_UW$  and  $PC\_VW$  to create cross-component correlation. See the discussion after parameter  $PC\_UW$  for details of the correlation.

To set  $\alpha_{uv} = 0$  and disable the correlation between the  $u$  and  $v$  components, enter the string “none.” Users also can enter the string “default” if you would like TurbSim to compute a default value for  $PC\_UV$ . The magnitudes of the defaults for site-specific models (GP\_LLJ, NWTCUP, WF\_UPW, WF\_07D, and WF\_14D) are functions of  $UStar$ ,  $RICH\_NO$ , height, mean hub-height wind speed, and shear across the rotor disk. The signs of the defaults are determined randomly. The default for the SMOOTH and TIDAL models is “none.”

### **$PC\_VW$ : Average $v'w'$ Reynolds Stress at the Hub [ $m^2/s^2$ ]**

The  $PC\_VW$  parameter is the desired average  $v'w'$  Reynolds stress (in  $m^2/s^2$ ) at the simulated hub point. It is used in conjunction with the parameters  $PC\_UW$  and  $PC\_UV$  to create cross-component correlation. See the discussion after parameter  $PC\_UW$  for details.

Users can enter the string “none” to set  $\alpha_{vw} = 0$  and disable the correlation between the  $v$  and  $w$  components. To have TurbSim compute a default value for  $PC\_VW$ , enter the string “default.” The magnitudes of the defaults for site-specific models are functions of  $UStar$ ,  $RICH\_NO$ , height, mean hub-height wind speed, and shear across the rotor disk. The signs of the defaults are determined randomly. The default for the SMOOTH and TIDAL models is “none.”

***IncDec1: Spatial Coherence for the u-Component Wind Speed [-, m<sup>-1</sup>]***

The *IncDec1* parameter defines the spatial coherence decrement,  $a$ , and offset parameter,  $b$ , for the  $u$ -component wind speed ( $K = u$ ). These two values are used to define the degree of spatial coherence between points on the grid using the definition

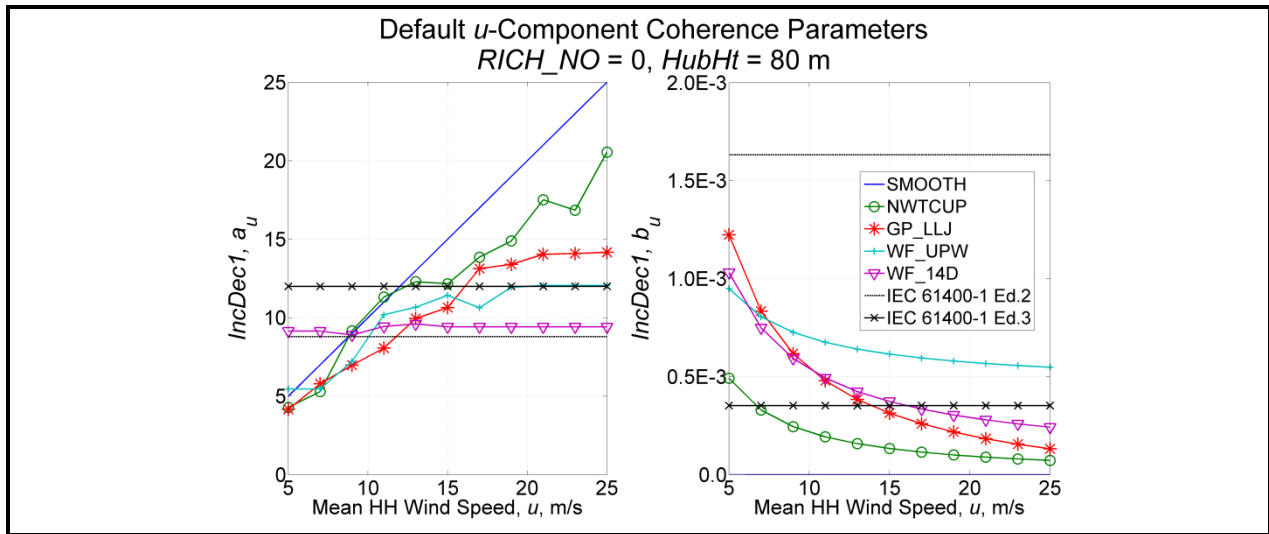
$$Coh_{i,j} = \exp \left( -a_K \left( \frac{r}{z_m} \right)^{CohExp} \sqrt{\left( \frac{f r}{u_m} \right)^2 + (b_K r)^2} \right), \quad (18)$$

where  $r$  is the distance between points  $i$  and  $j$ ,  $f$  is the cyclic frequency,  $CohExp$  is the coherence exponent input parameter, and  $z_m$  and  $u_m$  are the mean height and wind speed of points  $i$  and  $j$ . Please see the Spatial Coherence Models section of this document for more information.

The *IncDec1* decrement,  $a$ , must be a positive number. Users can enter “default” or both the  $a$  and  $b$  coherence parameters in quotation marks on the same line. For example, “10.0 0.1E-02” uses a coherence decrement of  $a = 10.0$  and an offset parameter of  $b = 0.1E-02 \text{ m}^{-1}$ . Omitting the quotation marks around the two input parameters causes TurbSim to use  $b = 0$ .

The default  $a$  parameter for the  $u$ -component is  $a_u = \bar{u}_{hub}$  for the SMOOTH and TIDAL models. The other non-IEC models base this default value on measured vertical coherence spectra from their respective datasets. The default  $a$  parameter for these models is a function of *HubHt* and *RICH\_NO* parameters, as well as the mean hub-height wind speed.

The default  $b$  parameter for the  $u$ -component is  $b_u = 0$  for the SMOOTH and TIDAL models. The other non-IEC models calculate the default  $b$  parameter as a function of mean hub-height wind speed. The GP\_LLJ and NWTcup models also use the *RICH\_NO* parameter to calculate the default  $b$ . Figure 13 shows the default parameters for neutral conditions (i.e., *RICH\_NO* = 0) using a value of 80 m for the *HubHt* parameter.



**Figure 13. Default  $u$ -component coherence parameters,  $IncDec1$ , ( $a_u$  left,  $b_u$  right) as a function of wind speed, using  $RICH\_NO = 0$  and  $HubHt = 80$  m (IEC values are plotted for comparison)**

### ***IncDec2: Spatial Coherence for the v-Component Wind Speed [-, m<sup>-1</sup>]***

The *IncDec2* parameter defines the spatial coherence decrement,  $a$ , and offset parameter,  $b$ , for the  $v$ -component wind speed using the coherence definition of Eq. (18) (with  $K = v$ ). Users can enter “default” for TurbSim to pick appropriate values for both  $a$  and  $b$ , or enter both  $a$  and  $b$  parameters in one set of quotation marks on the same line. See the discussion for *IncDec1* (above) for further details.

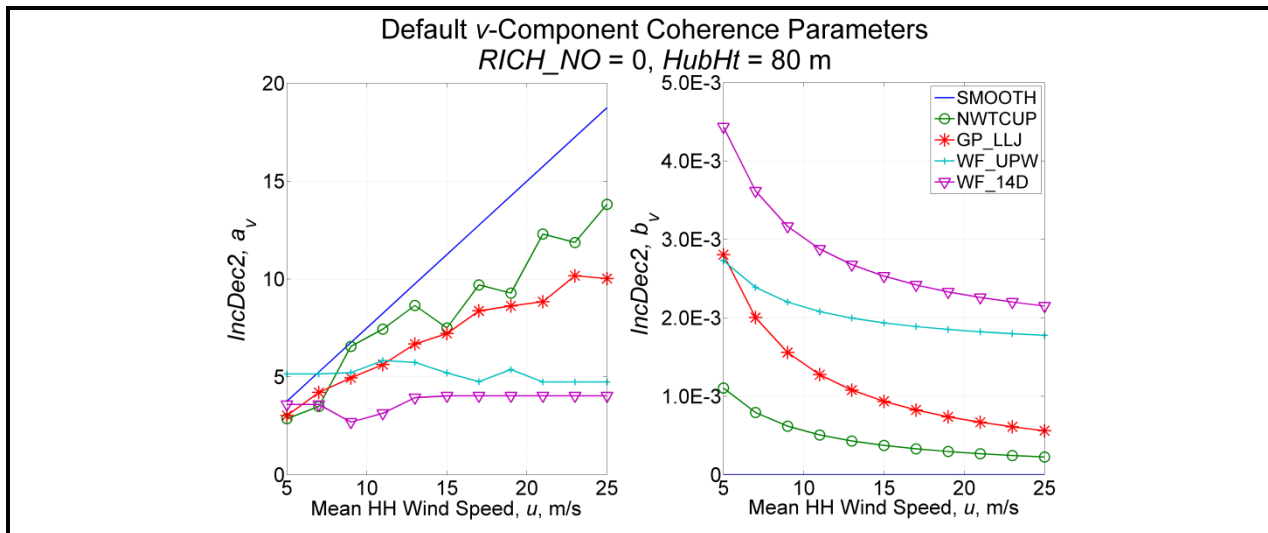
The default  $a$  parameter for the  $v$ -component is  $a_v = 0.75 \bar{u}_{hub}$  for the SMOOTH and TIDAL models. The other non-IEC models calculate the default value as a function of  $HubHt$  and  $RICH\_NO$  parameters, as well as the mean hub-height wind speed.

The default  $b$  parameter for the  $v$ -component is  $b_v = 0$  for the SMOOTH and TIDAL models. The other non-IEC models calculate the default  $b$  parameter as a function of mean hub-height wind speed. The GP\_LLJ and NWTcup models also use the  $RICH\_NO$  parameter to calculate the default  $b$ . Figure 14 shows the default parameters for neutral conditions using an 80-m  $HubHt$ .

### ***IncDec3: Spatial Coherence for the w-Component Wind Speed [-, m<sup>-1</sup>]***

The *IncDec3* parameter defines the spatial coherence decrement,  $a$ , and offset parameter,  $b$ , for the  $w$ -component wind speed using the coherence definition of Eq. (18) (with  $K = w$ ). Users can enter “default” for TurbSim to pick appropriate values for both  $a$  and  $b$ , or enter both  $a$  and  $b$  parameters in one set of quotes on the same line. See the discussion for *IncDec1* for further details.

The default  $a$  parameter for the  $w$ -component is  $a_w = 0.75 \bar{u}_{hub}$  for the SMOOTH and TIDAL models and  $a_w = 0.4 a_u$  for the three wind farm models (WF\_UPW, WF\_07D, and WF\_14D). The GP\_LLJ and NWTcup models calculate the default value as a function of the  $HubHt$  and



**Figure 14. Default  $v$ -component coherence parameters,  $IncDec2$ , ( $a_v$  left,  $b_v$  right) as a function of wind speed, using  $RICH\_NO = 0$  and  $HubHt = 80$  m (IEC does not define  $v$ -component coherence parameters)**



*RICH\_NO* parameters, as well as the mean hub-height wind speed.

The default  $b$  parameter for the  $w$ -component is  $b_w = 0$  for the SMOOTH and TIDAL models and  $b_w = 10b_u$  for the three wind farm models. The GP\_LLJ and NWTcup models calculate the default  $b$  parameter as a function of mean hub-height wind speed and the *RICH\_NO* parameter. Figure 15 shows the default parameters for neutral conditions using an 80-m *HubHt*.

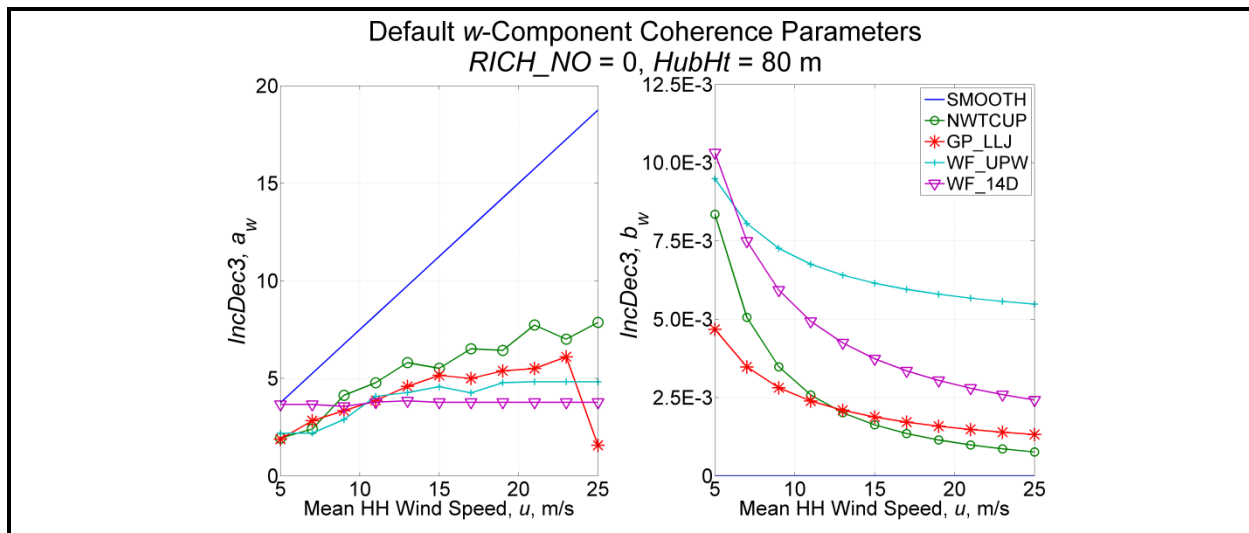
### **CohExp: Coherence Exponent [-]**

The *CohExp* parameter is the exponent in the coherence definition of Eq. (18). The same value of *CohExp* is used for all three wind components; enter a non-negative number or “default” to use the default value of 0.

### **Coherent Turbulence Scaling Parameters**

The coherent turbulence scaling parameters found in this section are used with non-IEC atmospheric (non-hydro) spectral models when the gradient Richardson number (*RICH\_NO*) is greater than  $-0.05$  and the option to create coherent turbulence time-step files has been selected (i.e., *WrACT* = true). Appendix C contains a flow chart showing the functions of the input parameters from this section.

TurbSim uses empirical values to calculate when and how coherent events—pieces (sections in time) of a Kelvin-Helmholtz (KH) billow simulated using either direct numerical simulation (DNS) or large-eddy simulation (LES)—should be added to the background turbulence. It creates a coherent turbulence time-step file that AeroDyn can read. The super-positioning of coherent events on the background turbulence occurs in AeroDyn in the inertial reference frame coordinate system that AeroDyn uses. The Coherent Structures section of this document discusses this topic further.



**Figure 15. Default  $w$ -component coherence parameters,  $IncDec3$ , ( $a_w$  left,  $b_w$  right) as a function of wind speed, using  $RICH\_NO = 0$  and  $HubHt = 80\text{ m}$  (IEC does not define  $w$ -component coherence parameters)**

**Table 8. Valid *CTEventFile* Entries**

<b>Input Value</b>	<b>Description</b>
DNS	Reads DNS event files ( <i>CTEventPath</i> \Events.dns)
LES	Reads LES event files ( <i>CTEventPath</i> \Events.les)
Random	Randomly chooses between LES and DNS (equal probability)

***CTEventPath*: Name of Coherent Turbulence Events path [-]**

The *CTEventPath* parameter is the name of the path that contains the coherent event definition files. Use quotation marks around the path name. This directory should contain files named “Events.les,” “Events.dns,” and “Events.xtm” as well as one or more files named “Eventxxxxx.dat” (with digits replacing the xxxxx). These event definition files and the associated binary data files that AeroDyn reads are provided in the coherent structure archive on the [TurbSim Web site](#) (in folder “EventData”).

***CTEventFile*: Type of Coherent Events [-]**

This parameter tells TurbSim which type of coherent event files to use. Valid entries are found in Table 8. In each individual simulation, all events are of the same type (either all LES or all DNS). TurbSim automatically uses LES events when KHTEST is specified for parameter *IECturbc*.

***Randomize*: Randomize Size and Location of KH Billow Pieces? [T/F]**

Set the *Randomize* parameter to “true” to randomize the size and location of the coherent structures in the rotor disk or to “false” to specify these values yourself. A value of “true” overrides the next three input parameters (*DistScl*, *CTLy*, and *CTLz*). Instead, the coherent structures are centered laterally and randomly chosen to cover either (1) the full rotor disk (75% of the time), (2) only the lower half of the disk (12.5% of the time), or (3) only the upper half (12.5% of the time).

***DistScl*: Disturbance Scale [-]**

The *DistScl* parameter is the disturbance scale, which determines the size of the coherent event data set relative to the rotor disk. It is the ratio of the height of the coherent dataset to the (assumed) rotor diameter. A value of 1.0 makes the coherent structures the height of the rotor disk; 0.5 makes them half the height of the rotor disk. If parameter *IECturbc* is KHTEST, TurbSim overrides *DistScl* with a value of 1.0. When *Randomize* is “true,” the value of this input is overridden (as discussed above).

***CTLy*: Lateral Location of Coherent Turbulence [-]**

This parameter laterally positions the coherent structures from the KH billow on the rotor disk. *CTLy* is the fractional location of the tower centerline from the right to left side (looking downwind) of the coherent event dataset. A value of 0.5 puts the tower centerline in the center of the billow. The coherent structures are periodic in the lateral direction so they cover the grid horizontally, regardless of the location of the tower centerline. Figure 16 shows coherent structure scaling with *CTLy* on the abscissa. If parameter *IECturbc* is KHTEST, TurbSim overrides *CTLy* with a value of 0.5. When *Randomize* is “true,” the value of this input is overridden (see the discussion of *Randomize*).

### **CTLz: Vertical Location of Coherent Turbulence [-]**

This parameter positions the coherent structures vertically on the rotor disk. *CTLz* is the fractional location of hub height from the bottom of the dataset. A value of 0.5 places the vertical center of the billow at hub height. The structures are constant above and below the top and bottom of the dataset. Figure 16 shows how the structures are scaled. If parameter *IECTurbc* is KHTEST, TurbSim overrides *CTLz* with a value of 0.5. When *Randomize* is “true,” the value of this input also is overridden (see the discussion of *Randomize*).

### **CTStartTime: Minimum Start Time for Coherent Turbulence [s]**

The *CTStartTime* parameter is used to determine where the first coherent structure will be placed in the time-step file. TurbSim ensures that the first event in the coherent time-step file does not occur before the time entered here (in seconds). This feature can be useful if you do not want a turbine to encounter coherent structures during the startup transient of a simulation.

## **Output Files**

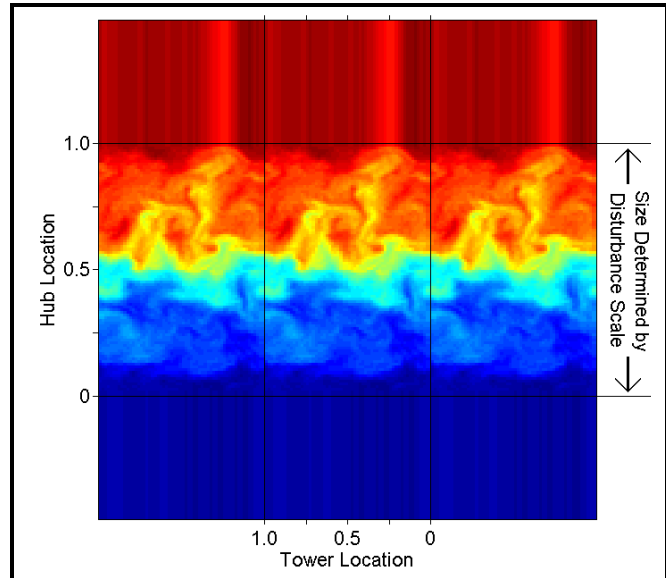
TurbSim can generate several different sets of output files. They have the root name of the TurbSim input file, and their extensions indicate what type of files they are. The Runtime Options section (above) describes how to tell TurbSim which sets to output.

### **Summary Files**

TurbSim generates a summary file for all runs. This summary file is a text file with a “.sum” extension. The first part of the file tells you what was specified in the input file. After that, TurbSim prints out many statistics for the run. These statistics are calculated using the entire *AnalysisTime* so if a shorter *UsableTime* was requested, the statistics of the output time series could be different than what is displayed in the summary file. Also keep in mind that the turbulence statistics are for the background turbulence only; they do not include effects of any coherent structures generated in coherent turbulence time-step files. If a coherent turbulence time-step file is generated, TurbSim prints the number of events and the total length of those events in the summary file. If Bladed-style FF files or separate tower output are requested, TurbSim adds another section that tells AeroDyn how to convert the normalized data to floating-point form.

### **Hub-Height Binary Files**

The hub-height binary files are in a machine-readable form designed to be read by GenPro, a postprocessor from the National Center for Atmospheric Research (NCAR). TurbSim gives these



**Figure 16. Coherent structure scaling (looking downwind): *CTLy* is the tower location, *CTLz* is the hub (height) location, and *DistScI* determines the size (m) relative to the rotor disk**

files a “.bin” extension. At each time step, TurbSim writes the values of a series of parameters in the binary file. The parameters are listed in Table 9 in the order in which they appear in the file. Each value is stored as a 4-byte floating-point (real) number. A MATLAB® script for reading these files is included in the TurbSim archive; it is named “Test\readHHbin.m.”

### Hub-Height Formatted Files

The hub-height formatted files contain essentially the same information as the hub-height binary files, but the parameters are written in columns in human-readable form. See Table 9 for the list of parameters. These files have a “.dat” extension.

### Hub-Height AeroDyn Formatted Files

These human-readable files are in a format compatible with AeroDyn. They have the “.hh” extension. See Table 10 for the file format; the *AeroDyn User’s Guide* [1] contains a detailed description of the parameters. The horizontal wind speed and wind direction are equivalent to the vector sum of the instantaneous  $U$ - and  $V$ -component time series from the hub-point, and the vertical wind speed is the corresponding  $W$ -component time series. TurbSim always sets the horizontal wind-shear, vertical linear wind-shear, and gust-speed parameters to zero in the AeroDyn hub-height files. The vertical power-law wind-shear exponent is constant for the entire time series. If the input wind-profile type (*WindProfileType*) is PL or IEC, the value in the AeroDyn HH file is the *PLExp* parameter; if *WindProfileType* is JET or LOG, the power law exponent is calculated based on the mean wind speeds at the top and bottom of the rotor disk:

**Table 9. Parameters in Hub-Height Binary and Formatted Files**

Column	Description
Time	Time from start of the simulation
U	$U$ -component wind speed
$u_h$	Horizontal wind speed [vectorial $U+V$ ]
$u_t$	Total wind speed [vectorial $U+V+W$ ]
V	$V$ -component wind speed
W	$W$ -component wind speed
$u'$	Fluctuating $u$ -component wind speed (the mean is removed)
$v'$	Fluctuating $v$ -component wind speed
$w'$	Fluctuating $w$ -component wind speed
$u'w'$	$u'w'$ Reynolds stress component
$u'v'$	$u'v'$ Reynolds stress component
$v'w'$	$v'w'$ Reynolds stress component
TKE	Turbulent kinetic energy
CTKE	Coherent turbulent kinetic energy

**Table 10. Format of Hub-Height AeroDyn Files**

Column	Description
Time	Time
HorSpd	Horizontal wind speed [vectorial $U+V$ ]
WndDir	Wind direction
VerSpd	Vertical wind speed ( $W$ component)
HorShr	Horizontal linear wind-shear parameter
VerShr	Vertical power-law wind-shear exponent
LnVShr	Vertical linear wind-shear parameter
GstSpd	Gust speed (not sheared by AeroDyn)

$$PLExp = \ln \left( \frac{\bar{u}(z_{top})}{u(z_{bottom})} \right) / \ln \left( \frac{z_{top}}{z_{bottom}} \right). \quad (19)$$

The column of plots on the right side of Figure 17 shows how AeroDyn uses the information in these HH files to produce wind speeds at any part of the volume surrounding the turbine.

### Full-Field TurbSim Binary Files

The FF TurbSim binary files are designed to be read by AeroDyn. They have a “.bts” extension. (The column of plots on the left side of Figure 17 shows how AeroDyn uses FF data.) TurbSim normalizes the time-series data (in the inertial reference frame coordinate system) and encodes them in 2-byte integers stored in these files. The first part of each file is a header that provides information about the grid and tells AeroDyn how to convert the integers to floating-point values. The wind speeds for the  $NumGrid\_Y \times NumGrid\_Z$  grids and the tower points (if specified) follow that. See Appendix D in this document for the file format. A MATLAB script for reading these files is included in the TurbSim archive; it is named “Test\readTSgrid.m.”

This binary format has been designed so that AeroDyn does not need to read any other file to properly convert the data to floating-point form. (In contrast, the FF Bladed-style binary files store scaling information in the summary file.) This format also provides the maximum resolution possible in two-byte integers.

### Full-Field Bladed-Style Binary Files

The FF Bladed-style binary files are designed to be read by both AeroDyn and GH Bladed. They have a “.wnd” extension. TurbSim normalizes the data (in the inertial reference frame coordinate system) and encodes them in 2-byte integers. The first part of the file is a header that provides information about the grid; the normalized wind speeds for the  $NumGrid\_Y \times NumGrid\_Z$  grid points follow that. See Appendix E in this guide for the file format. (The column of plots on the left side of Figure 17 shows how AeroDyn uses FF data.)

When generating these files, TurbSim adds a section to the end of the summary file that tells AeroDyn how to convert the data to floating-point form. To decode the data, AeroDyn must read both the summary file (with the “.sum” extension) and the binary FF file. TurbSim uses a newer file format than the format SNwind used. In general, this updated format retains more resolution in the normalized 2-byte integers than the previous encoding method did. A MATLAB script that reads these files is included in the TurbSim archive; it is named “Test\readBLgrid.m.”

### Tower Data Binary Files

The tower data binary files are similar to the FF Bladed-style binary files, except they contain data for points in a single line at the grid center—going from the bottom of the grid to the ground—using the same vertical resolution as the rest of the grid (see Figure 4). These files have a “.twr” extension. TurbSim normalizes the data (in the inertial reference frame coordinate system) and encodes them in 2-byte integers. The first part of the file is a header that provides information about the location of the tower points and size of the file; this header is followed by the wind speeds. When generating these files, TurbSim adds a section to the end of the summary file that indicates how to convert the data to floating-point form (this is the same section that is

generated for the FF Bladed-style “.wnd” binary files). See Appendix F in this guide for a more complete description of this binary format.

If a user requests FF binary files in TurbSim format (*WrADFF* = “true”), the tower points are normalized and stored as 2-byte integers along with the full-field grid data in the file with a “.bts” extension. In that case, a separate file with the “.twr” extension is not generated.

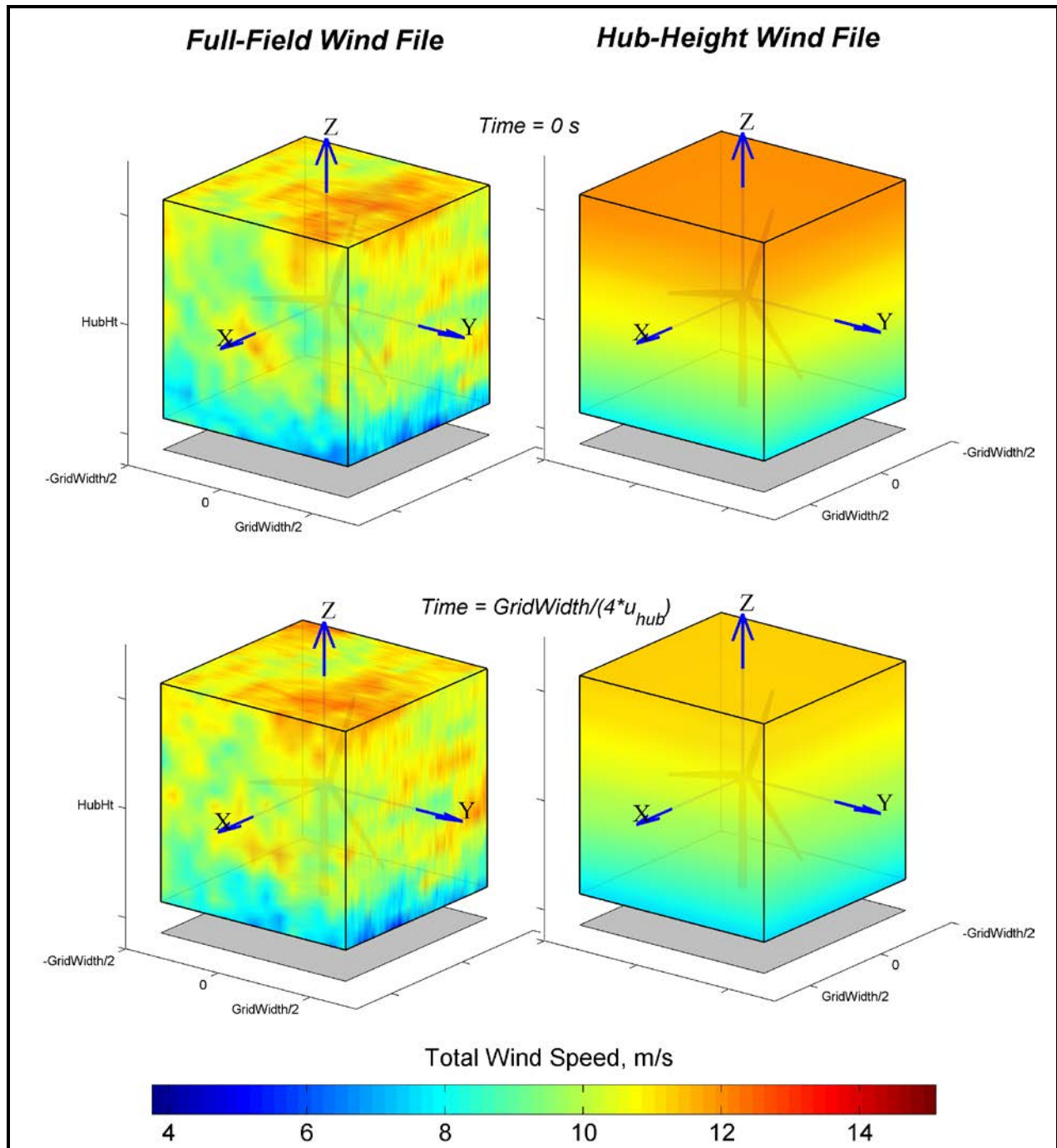
### **Full-Field Formatted Files**

The FF formatted files are the traditional SNLWIND-3D FF output. These three files are human readable (text), but use five times more storage than the binary files. Early versions of AeroDyn could read these files, but AeroDyn no longer supports this format. There is one file for each component, with “.u,” “.v,” and “.w” file extensions, respectively.

Each of the files begins with a header containing with some basic information about the simulation, and blocks of data follow. The first line in each block includes the time and the hub-height wind speed. Following that line is a table with the number of rows and columns being the number of grid points specified in the input file. The tables contain the wind speeds for the different grid points. Their orientation is as if you are looking upwind (i.e., *Y* increases from left to right, and *Z* increases from bottom to top), and all of the velocities are in the inertial reference frame coordinate system. A MATLAB script for reading these files is included in the TurbSim archive; it is named “Test/loadFFtxt.m.”

### **Coherent Turbulence Time-Step Files**

One of the unique features of TurbSim is its ability to add coherent turbulence events based on data obtained from numerical simulations of a Kelvin-Helmholtz billow. The data comes from two sources: a large-eddy simulation from NCAR and a direct numerical simulation from Colorado Research Associates (CoRA), both of Boulder, Colorado. Because the grid size of the coherent events is very large (roughly 92 x 92 points), these events are not added directly to the background turbulence in TurbSim. Instead, we create coherent turbulence time-step files, which have a “.cts” extension. These text files contain a header indicating how to scale the non-dimensional coherent structures; the header is followed by the times and file numbers of the subset of LES or DNS data that define the coherent events. AeroDyn reads this file along with the background wind file and adds the two wind fields together. This feature can be used only in programs that use AeroDyn v12.57 or later. See the Using Coherent Turbulence Time-Step Files with AeroDyn section of this document for more information.



**Figure 17. Example TurbSim FF and HH wind files as implemented in AeroDyn.**  
 The bottom left plot shows the FF grids after marching  $GridWidth/4$  meters (along positive X) from the position in the upper left plot; HH wind files (right column) do not march through the turbine. At each time step, the FF wind velocity at  $X = GridWidth/2, Y = 0, Z = HubHt$  is identical to the HH wind velocity at  $X = 0, Y = 0, Z = HubHt$ . Because TurbSim sets the horizontal shear to 0 in the HH files, the velocity does not change with either X or Y. Thus, the wind velocities in the FF and HH files are identical at  $X = GridWidth/2, Y = 0, Z = HubHt$  (where the X axis on the plots emerges from the wind volume).

## Spectral Models

TurbSim uses a modified version of the Sandia method [4] to generate time series based on spectral representation. Several different spectral models are available, including two IEC models, the Risø smooth-terrain model, and several NREL site-specific models (NWTCUP, GP\_LLJ, WF\_UPW, WF\_07D, and WF\_14D). This section describes the velocity spectra used in each of the models and discusses the measurements used to develop scaling for the site-specific models. Standard deviations,  $\sigma$ , have been calculated by integrating the velocity spectra,  $S$ :

$$\sigma^2 = \int_0^{\infty} S(f) df. \quad (20)$$

Plots comparing the velocity spectra of the different models are presented in Appendix G.

### IECKAI: The IEC Kaimal Model

The IEC Kaimal model is defined in IEC 61400-1 2<sup>nd</sup> ed. [23], and 3<sup>rd</sup> ed. [20] and assumes neutral atmospheric stability ( $RICH\_NO = 0$ ).<sup>1</sup> The spectra for the three wind components,  $K = u, v, w$ , are given by

$$S_K(f) = \frac{4\sigma_K^2 L_K / \bar{u}_{hub}}{\left(1 + 6f L_K / \bar{u}_{hub}\right)^{5/3}}, \quad (21)$$

where  $f$  is the cyclic frequency and  $L_K$  is an integral scale parameter. The IEC 61400-1 standard defines the integral scale parameter to be

$$L_K = \begin{cases} 8.10\Lambda_U, & K = u \\ 2.70\Lambda_U, & K = v \\ 0.66\Lambda_U, & K = w \end{cases}, \quad (22)$$

where the turbulence scale parameter,  $\Lambda_U$ , is

$$\Lambda_U = \begin{cases} 0.7 \cdot \min(30\text{m}, HubHt), & \text{Edition 2} \\ 0.7 \cdot \min(60\text{m}, HubHt), & \text{Edition 3} \end{cases}. \quad (23)$$

(Note that the function  $\min(x_1, x_2)$  in Eq. (23) indicates the minimum of  $x_1$  and  $x_2$ .) The relationships between the standard deviations are defined to be

---

<sup>1</sup> This model differs slightly from the original neutral spectra defined by Kaimal.



$$\begin{aligned}\sigma_v &= 0.8\sigma_u \\ \sigma_w &= 0.5\sigma_u.\end{aligned}\tag{24}$$

The velocity spectra (and standard deviations) of the IECKAI model are assumed to be invariant across the grid. In practice, a small amount of variation in the  $u$ -component standard deviation occurs due to the spatial coherence model.

### IECVKM: The IEC Von Karman Isotropic Model

This IEC model is defined in IEC 61400-1 2<sup>nd</sup> ed. [23] for isotropic turbulence and neutral atmospheric stability. The velocity spectra for the wind components are given by

$$S_u(f) = \frac{4\sigma_u^2 L/\bar{u}_{hub}}{\left(1 + 71\left(f L/\bar{u}_{hub}\right)^2\right)^{5/6}},\tag{25}$$

and

$$S_K(f) = \frac{2\sigma_K^2 L/\bar{u}_{hub}}{\left(1 + 71\left(f L/\bar{u}_{hub}\right)^2\right)^{1/6}} \left(1 + 189\left(f L/\bar{u}_{hub}\right)^2\right)\tag{26}$$

for  $K = v, w$ . In these equations,  $f$  is the cyclic frequency and  $L$  is an integral scale parameter.  $L$  is defined using the turbulence scale parameter,  $\Lambda_U$ , from Eq. (23):

$$L = 3.5\Lambda_U\tag{27}$$

The IEC standard defines the relationship between the standard deviations of the components to be

$$\sigma_v = \sigma_w = \sigma_u.\tag{28}$$

The velocity spectra (and standard deviations) of the IECVKM model are invariant across the grid. In practice, a small amount of variation in the  $u$ -component standard deviation occurs due to the spatial coherence model.

### SMOOTH: The Risø Smooth-Terrain Model

TurbSim also offers the Risø smooth-terrain model (SMOOTH), based on work by Højstrup et al. [27] and Olesen et al. [28]. This spectral model has separate equations for stable/neutral and for unstable flows. The SMOOTH model (as well as the site-specific models) defines the velocity spectra using local height and wind speed; this contrasts with the IEC models which use the wind speed and height of the hub to define the spectra at all points. The spectra from the SMOOTH model also form the basis for the spectra for all the site-specific models.

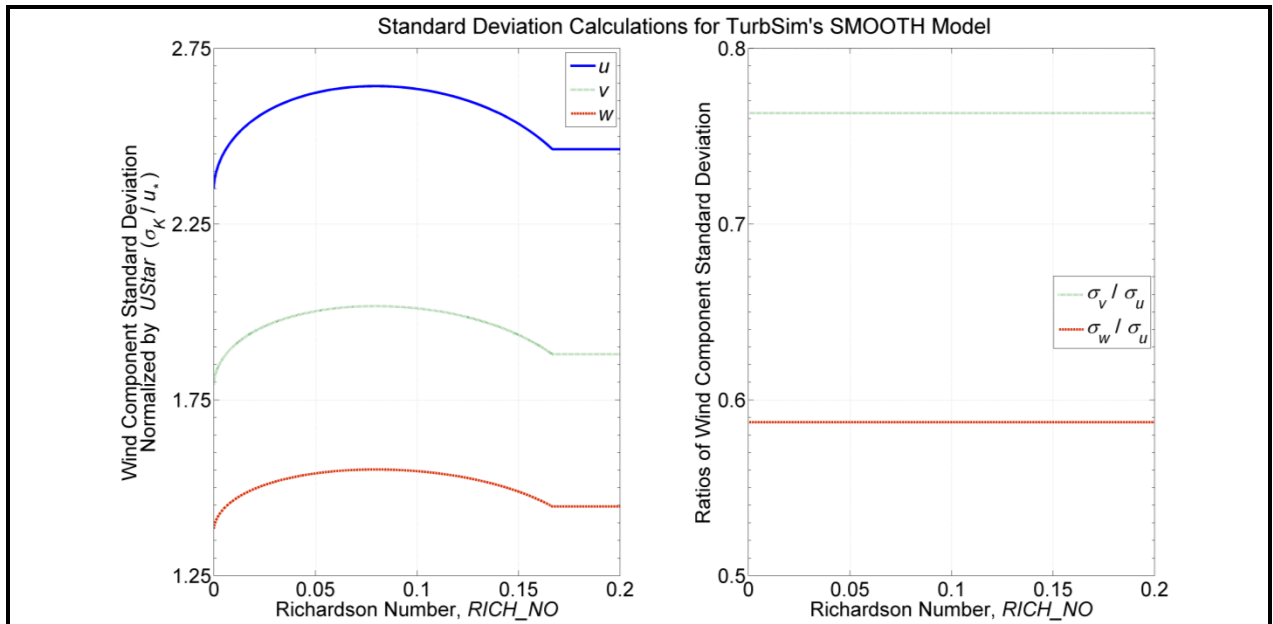
For stable and neutral conditions ( $RICH\_NO \geq 0$ ), the SMOOTH-model velocity spectra for the three wind components,  $K$ , are given by

$$S_K(f) = UStar^2 \frac{s_{1,K} \left( \frac{z}{u \phi_M} \right) \left( \frac{\phi_E}{\phi_M} \right)^{2/3}}{1.0 + s_{2,K} \left( \frac{fz}{u \phi_M} \right)^{5/3}}, \quad (29)$$

where  $f$  is the cyclic frequency,  $UStar$  is the friction velocity input parameter,  $\bar{u}$  is the mean wind speed at height  $z$ , and  $\phi_E$  and  $\phi_M$  are functions of the stability parameter,  $RICH\_NO$ . The two scales,  $s_1$  and  $s_2$ , are defined as follows for each component:

$$\langle s_{1,K}, s_{2,K} \rangle = \begin{cases} \langle 79.0, 263.0 \rangle & K = u \\ \langle 13.0, 32.0 \rangle & K = v \\ \langle 3.5, 8.6 \rangle & K = w \end{cases}. \quad (30)$$

The theoretical standard deviations of the wind components in stable and neutral conditions are plotted in Figure 18. These values are calculated assuming infinite, continuous spectra with no spatial coherence or time-domain cross-component correlation (i.e., the input mean hub Reynolds stresses,  $PC\_UW$ ,  $PC\_UV$ , and  $PC\_VW$ , are “none”). The standard deviations theoretically are constant across the rotor disk (using the same assumptions); in practice, however, they can appear to vary with height (depending on the input values used). This variance should decrease with increased record length. The relationships between the components’ standard deviations are



**Figure 18. SMOOTH-model stable/neutral turbulence as a function of  $RICH\_NO$ : left: standard deviation normalized by  $UStar$ , right: Relationships between components’ standard deviations**

$$\begin{aligned}\sigma_v &= 0.76\sigma_u \\ \sigma_w &= 0.59\sigma_u\end{aligned}\quad (31)$$

For unstable flows, ( $RICH\_NO < 0$ ), the SMOOTH spectra are modeled as the sum of low- and high-frequency spectral peaks:

$$S(f) = S_{low}(f) + S_{high}(f). \quad (32)$$

These two peaks are defined for the three wind components as follows:

$$S_u(f) = UStar^2 \left( \frac{0.5 \frac{ZI}{u} \left(\frac{ZI}{-L}\right)^{\frac{2}{3}}}{1 + 2.2 \left(\frac{fZI}{u}\right)^{\frac{5}{3}}} + \frac{105 \frac{z}{u(1+15\frac{z}{ZI})} \left(1 - \frac{z}{ZI}\right)^2}{\left(1 + 33 \frac{fz}{u(1+15\frac{z}{ZI})}\right)^{\frac{5}{3}} \left(1 + 15 \frac{z}{ZI}\right)^{\frac{2}{3}}} \right), \quad (33)$$

$$S_v(f) = UStar^2 \left( \frac{0.95 \frac{ZI}{u} \left(\frac{ZI}{-L}\right)^{\frac{2}{3}}}{\left(1 + 2 \frac{fZI}{u}\right)^{\frac{5}{3}}} + \frac{17 \frac{z}{u(1+2.8\frac{z}{ZI})} \left(1 - \frac{z}{ZI}\right)^2}{\left(1 + 9.5 \frac{fz}{u(1+2.8\frac{z}{ZI})}\right)^{\frac{5}{3}} \left(1 + 2.8 \frac{z}{ZI}\right)^{\frac{2}{3}}} \right), \quad (34)$$

and

$$S_w(f) = UStar^2 \left( \frac{0.95 \frac{ZI}{u} \left(\frac{ZI}{-L}\right)^{\frac{2}{3}}}{\left(1 + 2 \frac{fZI}{u}\right)^{\frac{5}{3}}} \left( \frac{\left(\frac{fz}{u}\right)^2 + \left(0.3 \frac{z}{ZI}\right)^2}{\left(\frac{fz}{u}\right)^2 + (0.15)^2} \right)^{\frac{1}{2}} + \frac{2 \frac{z}{u} \left(1 - \frac{z}{ZI}\right)^2}{1 + 5.3 \left(\frac{fz}{u}\right)^{\frac{5}{3}}} \right), \quad (35)$$

where  $f$  is the cyclic frequency,  $UStar$  and  $ZI$  are input parameters, and  $\bar{u}$  is the mean wind speed at height  $z$ .  $L$  is the Monin-Obukhov length parameter, which is a function of  $RICH\_NO$  and  $HubHt$ .

The standard deviations of the wind components in unstable atmospheric conditions vary with height, the mixing layer depth ( $ZI$ ), and  $L$ . Their approximate values are determined from the following equations:

$$\sigma_u^2 \approx UStar^2 \left( 0.62 \left(\frac{ZI}{-L}\right)^{\frac{2}{3}} + 4.77 \left(1 - \frac{z}{ZI}\right)^2 \left(1 + 15 \frac{z}{ZI}\right)^{-\frac{2}{3}} \right) \quad (36)$$

$$\sigma_v^2 \approx UStar^2 \left( 0.71 \left(\frac{ZI}{-L}\right)^{\frac{2}{3}} + 2.68 \left(1 - \frac{z}{ZI}\right)^2 \left(1 + 2.8 \frac{z}{ZI}\right)^{-\frac{2}{3}} \right) \quad (37)$$

$$\sigma_w^2 \approx UStar^2 \left( 0.71 \left(\frac{ZI}{-L}\right)^{\frac{2}{3}} + 1.46 \left(1 - \frac{z}{ZI}\right)^2 \right) \quad (38)$$

## NWTCUP: The NREL National Wind Technology Center Model

The NWTCUP model, based on measurements from the NWTC/LIST project, represents turbulent inflow characteristics at the NWTC, downwind of a major mountain range. In this project, three towers were installed 1.5 rotor diameters upwind of the 600-kW NWTC Advanced Research Turbine (ART). The central tower contained three-axis sonic anemometers at 15 m, 37 m, and 58 m above ground level; cup anemometers and wind vanes were located at 3 m, 37 m, and 58 m; and temperature measurements were obtained at 3 m, 15 m, 37 m, and 58 m. Two additional towers, which were located 21 m north and south of the central tower, contained three-axis sonic anemometers at 37 m. Neil Kelley et al. discuss this project and the instrumentation further [29].

The spectra for this model are based on the 40-Hz time series data collected by the five sonic anemometers. The default spatial coherence parameters generated for this model are based on vertical coherence measured by the sonic anemometers on the central tower.

For neutral and stable flows, the NWTCUP spectra are defined by adding scaled versions of the SMOOTH-model spectra:

$$S_K(f) = \sum_{i=1}^{NumPeaks_K} p_{i,K} S_{K,SMOOTH}(F_{i,K} f), \quad (39)$$

where  $NumPeaks_K = 2$  for all wind components  $K = u, v, w$  and the function  $S_{K,SMOOTH}$  is defined in Eq. (29). All of the  $p_{i,K}$  and  $F_{i,K}$  scaling factors are functions of  $RICH\_NO$ . Figure 19 shows the standard deviations for the three wind components and the ratios between the components' standard deviations.

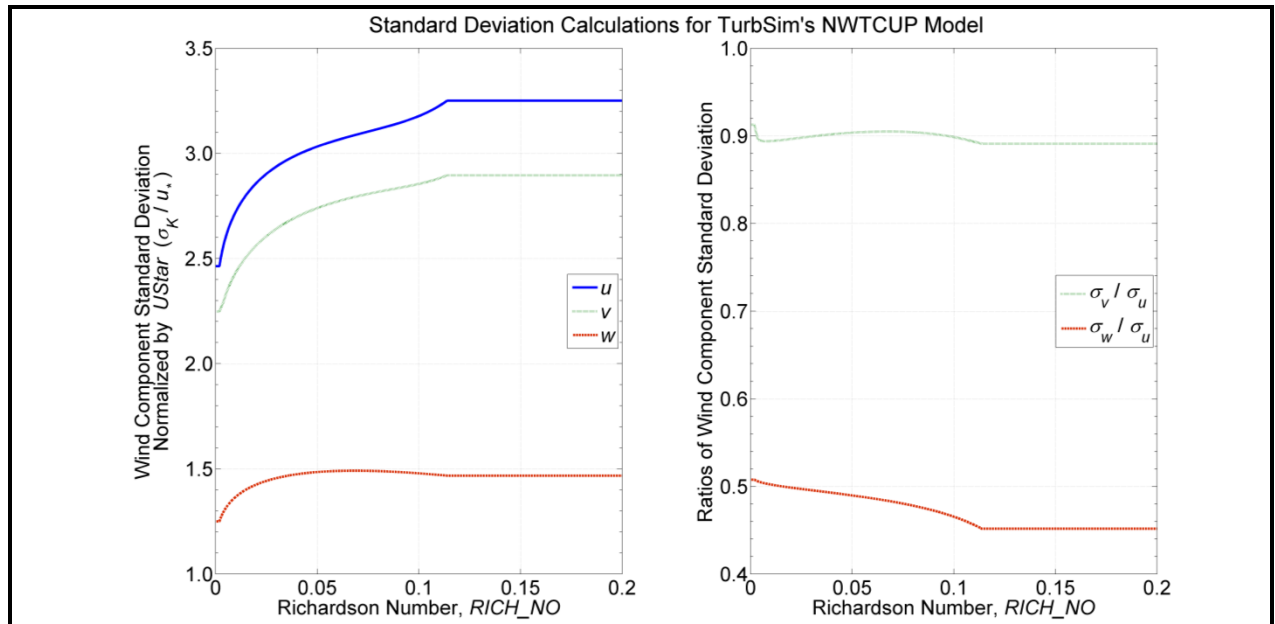


Figure 19. NWTCUP-model stable/neutral turbulence as a function of  $RICH\_NO$ : left: standard deviation normalized by  $UStar$ , right: relationships between components' standard deviations

For unstable flows, the NWTcup model modifies the SMOOTH-model low- and high-frequency peaks from Eq. (33) through Eq. (35):

$$S_K(f) = p_{1,K} S_{K,low,SMOOTH}(F_{1,K} f) + p_{2,K} S_{K,high,SMOOTH}(F_{2,K} f). \quad (40)$$

The scaling factors  $p_{1,K}$ ,  $p_{2,K}$ ,  $F_{1,K}$ , and  $F_{2,K}$ , which are empirically derived from spectra calculated using NWTcup/LIST velocity measurements, are functions of the *RICH\_NO* and *UStar* parameters. The standard deviations are similar to those of the unstable SMOOTH-model, scaled by the  $p_{1,K}$  and  $p_{2,K}$  terms.

### GP\_LLJ: The NREL Great Plains Low-Level Jet Model

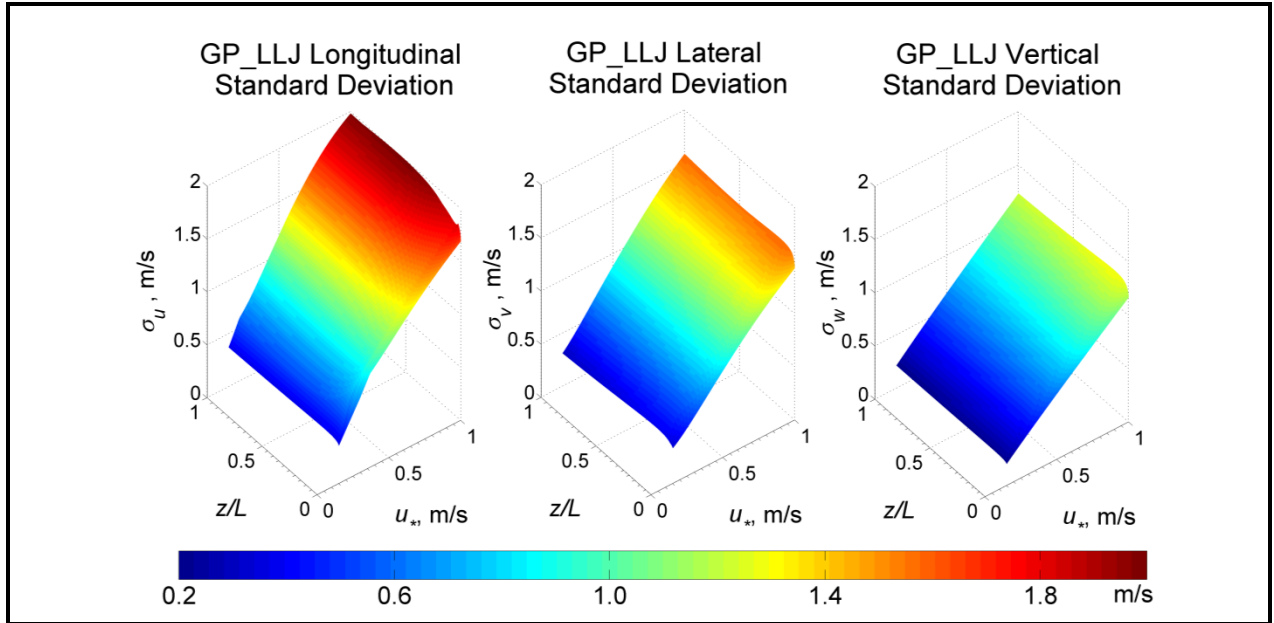
The Great Plains model (GP\_LLJ) is based on measurements from a 120-m tower and from an acoustic wind profiler (SODAR [sonic detection and ranging]) obtained during the Lamar Low-Level Jet Project in southeastern Colorado. The tower included three-axis sonic anemometers at 54 m, 67 m, 85 m, and 116 m above the ground; cup anemometers and direction vanes located at 3, 52, and 113 m; and temperature measurements obtained at 3 m, 52 m, 83 m, and 113 m. The SODAR provided measurements of wind speed and direction at 10-m vertical increments from 20 m to 500 m. The spectra and spatial coherence parameters defined in this model are based on 20-Hz time-series data collected at the sonic anemometers. Please refer to Neil Kelley et al. [30] for details of that project.

The GP\_LLJ model defines vertical profiles of stability and of shear velocity (i.e., stability and shear velocity are functions of height). The stability profile—related to *RICH\_NO*—is a local Monin-Obukhov stability parameter,  $z/L$ , and the shear velocity profile is a local  $u_*$  value. The values used for these profiles are placed in the TurbSim summary file. Both of these profiles are calculated based on height, wind speed, and *RICH\_NO*. The shear velocity profile also relies on *UStar* and  $u_{*0}$ , which is defined in Eq. (14).

The  $z/L$  and  $u_*$  profiles are used to scale the GP\_LLJ velocity spectra (in contrast, the other models use the *UStar* and *RICH\_NO* parameters, which are averaged values). For stable and neutral flows, the spectra are defined by adding peaks from the form of the SMOOTH-model spectra:

$$S_K(f) = \frac{u_*^2}{UStar^2} \sum_{i=1}^{NumPeaks_K} p_{i,K} S_{K,SMOOTH}(F_{i,K} f), \quad (41)$$

where the function  $S_{K,SMOOTH}$  is defined in Eq. (29), using the local stability parameter,  $z/L$ , to determine the values of functions  $\phi_E$  and  $\phi_M$  (instead of using *RICH\_NO* as the SMOOTH model does). The  $u$  and  $v$  components have two peaks ( $NumPeaks_K = 2$ ,  $K = u, v$ ), and the  $w$  component is modeled with only one peak ( $NumPeaks_w = 1$ ). The scaling factors  $p_{i,K}$  and  $F_{i,K}$  are functions of both  $z/L$  and  $u_*$ . The standard deviations for the three wind components are plotted in Figure 20. The ratios between the components satisfy the following inequalities:



**Figure 20. GPLLJ-model stable/neutral turbulence as a function of local stability and shear velocities**

$$0.70 \leq \frac{\sigma_v}{\sigma_u} \leq 0.98, \quad (42)$$

and

$$0.52 \leq \frac{\sigma_w}{\sigma_u} \leq 0.71. \quad (43)$$

By design, most of the LLLJP data was collected in the stable atmosphere. As a result, there was not enough data to create a model of the spectra in unstable flows. Instead, the GP\_LLJ spectra for unstable atmospheric conditions use the same equations as the SMOOTH model spectra in Eq. (33) through Eq. (35). The one difference is that the GP\_LLJ scales the spectra using the local  $u_*$  values instead of the  $UStar$  input parameter. The GP\_LLJ spectra for unstable flows are thus defined as

$$S_K(f) = \frac{u_*^2}{UStar^2} S_{K,SMOOTH}(f). \quad (44)$$

### **WF\_UPW: The NREL Wind Farm, Upwind Model**

The WF\_UPW wind-farm model is based on measurements taken from a 50-m tower upwind of a large wind plant in San Gorgonio Pass, California. The spectra were calculated using 50-Hz wind-speed measurements from a three-axis sonic anemometer located 23 m above the ground. The parameters for spatial coherence were calculated using measurements from 5-Hz cup anemometers and direction vanes located at 5 m, 10 m, 20 m and 50 m above ground level. Please refer to Kelley [5] for details of the model development and Kelley and Wright [31] for further details on the measurements.

For neutral and stable flows, the WF\_UPW spectra are defined by adding scaled versions of the SMOOTH-model spectra, using Eq. (39). All of the wind components use two spectral peaks ( $NumPeaks_K = 2, K = u, v, w$ ) and each of the scaling factors  $p_{i,K}$  and  $F_{i,K}$  are functions of  $RICH\_NO$ . Figure 21 shows the standard deviations for the three wind components and the ratios between the components' standard deviations.

For unstable flows, the WF\_UPW model modifies the SMOOTH-model low- and high-frequency peaks, using Eq. (40). The scaling factors  $p_{1,K}, p_{2,K}, F_{1,K},$  and  $F_{2,K}$  are functions of the  $RICH\_NO$  parameter. The resulting standard deviations are similar to those of the unstable SMOOTH model, but scaled by the  $p_{1,K}$  and  $p_{2,K}$  terms.

### WF\_14D: The NREL Wind Farm, Downwind Model (14 Rotor Diameters)

The WF\_14D wind-farm model is based on measurements taken on a 50-m tower downwind of a 41-row wind plant in San Geronio Pass, California. The tower was approximately 14-rotor-diameters downwind of the plant, which consisted of 23-m hub-height Micon 65/13 machines with 16-m rotor diameters.

The spectra were calculated using 50-Hz wind-speed measurements from a three-axis sonic anemometer located 23 m above the ground. The parameters for spatial coherence were calculated using measurements from 5-Hz cup anemometers and direction vanes located at 5 m, 10 m, 20 m, and 50 m above ground. The development of this model is described by Kelley [5], and the measurements are discussed further in Kelley and Wright [31].

For neutral and stable flows, the WF\_14D spectra are defined by adding scaled versions of the SMOOTH-model spectra, also using Eq. (39). All wind components use two spectral peaks

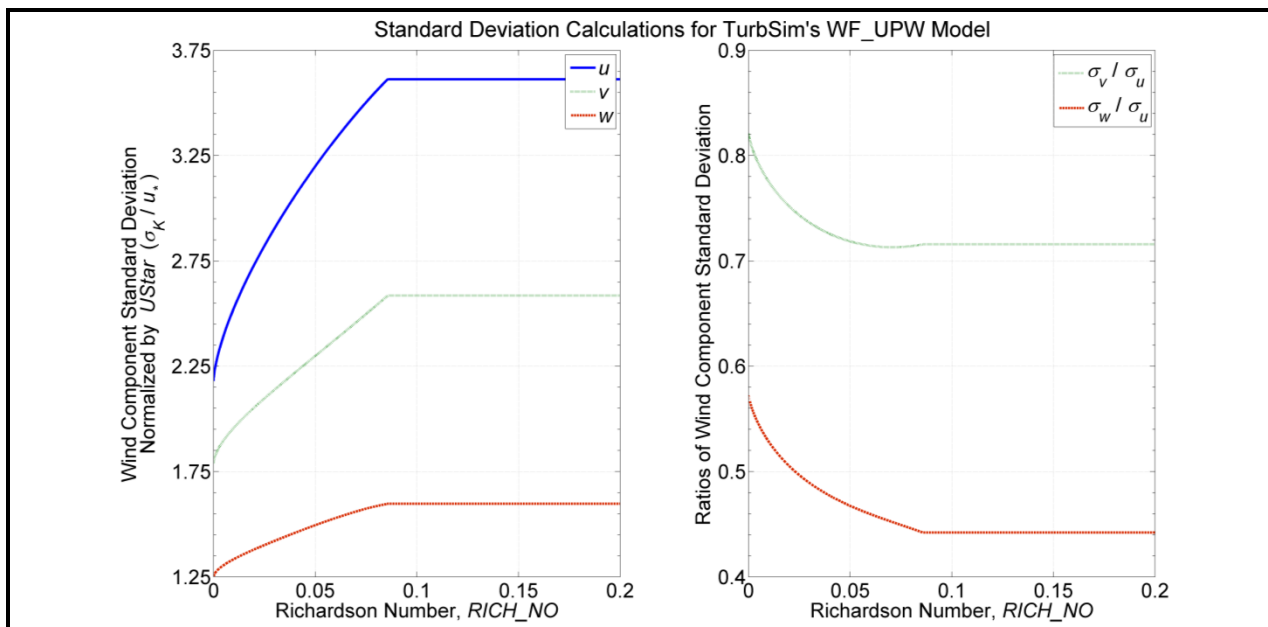


Figure 21. WF\_UPW-model stable/neutral turbulence as a function of  $RICH\_NO$ : left: standard deviation normalized by  $UStar$ , right: relationships between components' standard deviations

( $NumPeaks_K = 2, K = u, v, w$ ) and each of the scaling factors  $p_{i,K}$  and  $F_{i,K}$  are functions of  $RICH\_NO$ . Figure 22 shows the standard deviations for the three wind components and the ratios between the components' standard deviations.

For unstable flows, the WF\_14D model modifies the SMOOTH-model low- and high-frequency peaks listed in Eq. (33) through Eq. (35):

$$S_K(f) = p_{1,K} S_{K,low,SMOOTH}(F_{1,K} f) + \sum_{i=2}^{NumPeaks_K} p_{i,K} S_{K,high,SMOOTH}(F_{i,K} f). \quad (45)$$

The  $u$ - and  $w$ -component spectra have two peaks ( $NumPeaks_K = 2, K = u, w$ ). For the  $v$ -component spectra, Kelley found a third peak ( $NumPeaks_v = 3$ ), which he attributed to wakes from the wind turbines upstream. The scaling factors  $p_{i,K}$  and  $F_{i,K}, i = 1, 2, \dots, NumPeaks_K$ , are functions of the  $RICH\_NO$  parameter. The resulting standard deviations are similar to those of the unstable SMOOTH-model, scaled by the  $p_{i,K}$  terms.

### WF\_07D: The NREL Wind Farm, Downwind Model (7 Rotor Diameters)

The scaling for the WF\_07D wind-farm model is based on measurements taken at row 37 of a 41-row wind plant in San Geronio Pass, California for the SERI Thin-Airfoil Blade Atmospheric Performance Test [32]. The 16-Hz measurements were obtained from a three-axis sonic anemometer 23-m above the ground, on a tower approximately 7-rotor-diameters downwind of a row of operating Micon 65/13 wind turbines.

These measurements were used to calculate the scaling for coherent structures and default input parameters. The measurements used to form the scaling for the WF\_07D model, however, were

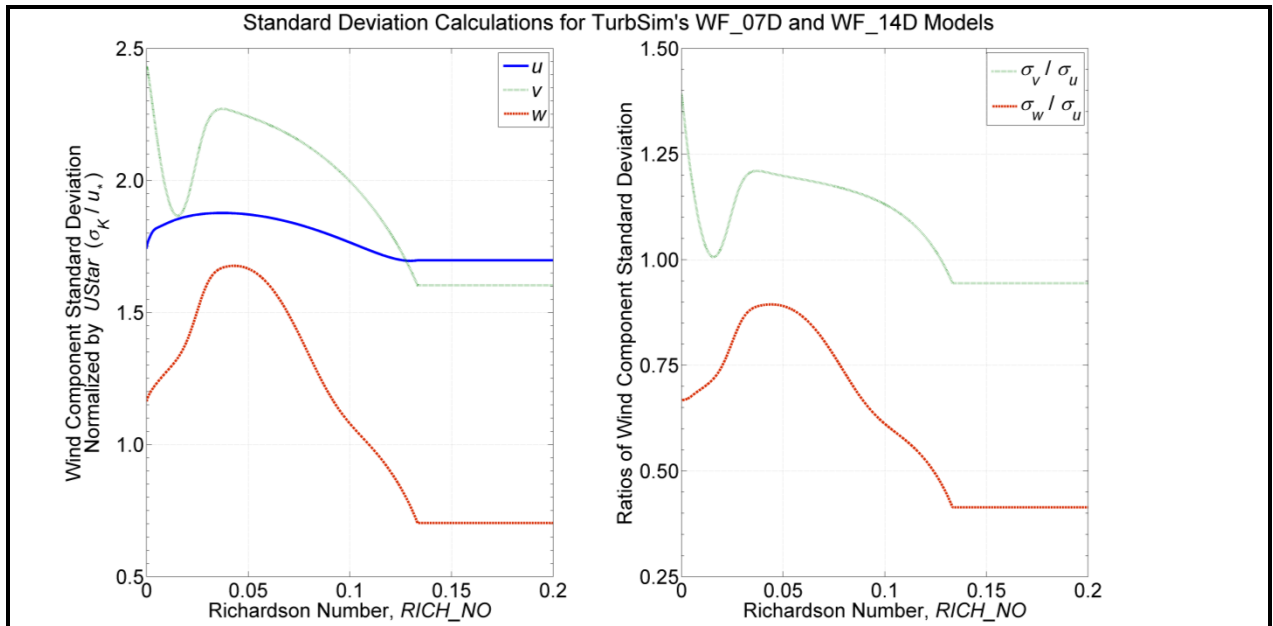


Figure 22. WF\_07D- and WF\_14D-model stable/neutral turbulence as a function of  $RICH\_NO$ : left: standard deviation normalized by  $U_{Star}$ , right: ratios of standard deviations



not sufficient to develop spectral scaling or spatial coherence. As a result, the WF\_07D model uses the same equations for the velocity spectra and spatial coherence as the WF\_14D model.

### TIDAL: The NREL/UW Tidal Channel Model

The TIDAL model for water turbulence is based on measurements taken near Marrowstone Island in Puget Sound Washington [33]. These measurements were taken in a tidally-mixed tidal boundary layer 4.6 meters above the bottom in 18 meters of water. The spectral form is essentially the same as the SMOOTH spectral model, but the spectral amplitude and shear are scaled directly based on this tidal channel's turbulent kinetic energy (TKE) and shear rather than implicitly from atmospheric boundary layer theory. In particular, the form is:

$$S_K(f) = \frac{\sigma_K^2 s_{1,K} \left( \frac{\partial u}{\partial z} \right)^{-1}}{1 + s_{2,K} \left( \frac{f}{\partial u / \partial z} \right)^{5/3}}, \quad (46)$$

where the empirically determined coefficients are (for frequency,  $f$ , in hertz and  $\partial u / \partial z$  in 1/second):

$$\langle s_{1,K}, s_{2,K} \rangle = \begin{cases} \langle 1.21, 4.30 \rangle & K = u \\ \langle 0.33, 0.50 \rangle & K = v \\ \langle 0.23, 0.26 \rangle & K = w \end{cases}. \quad (47)$$

The shear,  $\partial u / \partial z$ , is calculated internally from the specified mean velocity profile. In the case of a logarithmic velocity profile, the shear is proportional to  $u/z$  and this form is essentially the same as the SMOOTH spectral model. The component-TKE levels,  $\sigma_K^2$  are determined based on an exponential profile proportional to  $UStar^2$ :

$$\sigma_K^2 = UStar^2 \mu_K e^{-2z/RefHt}, \quad (48)$$

where,  $\mu_u = 4.5$ ,  $\mu_v = 2.25$ ,  $\mu_w = 0.9$ , are empirically determined coefficients from the Marrowstone Island site.  $RefHt$  is the reference height input parameter at which the input parameter  $Uref$  is specified. For simulating fully mixed tidally forced boundary layers,  $RefHt$  should be approximately equal to the water depth, and  $Uref$  the surface velocity. A simple way to match observed velocity and TKE ( $\sigma_K^2$ ) profiles is to make minor adjustments to  $Uref$  and  $RefHt$ .

The TurbSim archive includes a “TurbSim\_Hydro.inp” sample input file. The parameters set in “TurbSim\_Hydro.inp” are more appropriate to water turbulence and tidal channels than the “TurbSim.inp” file, which has default values appropriate for atmospheric turbulence. Note that many of the values in the input file are not used for the TIDAL spectral model (e.g.  $Z0$ ,  $RICH\_NO$ ,  $ZI$ , and all of the Coherent Turbulence Scaling Parameters)...

### Spatial Coherence Models

In general, the spatial coherence between points  $i$  and  $j$  is defined as

$$Coh_{i,j}(f) = \frac{|S_{ij}(f)|}{\sqrt{S_{ii}(f)S_{jj}(f)}}, \quad (49)$$

where  $f$  is the frequency,  $S_{ii}$  is the power spectral density as defined in the Spectral Models section, and  $S_{ij}$  is the cross-spectral density. This coherence adds correlation between the same wind components at two spatially separated points (e.g.,  $u_i$ - $u_j$  correlation, not  $u$ - $v$  correlation).

The coherence functions that are implemented in TurbSim are described below.

### Coherence for IEC Spectral Models

The coherence function for the  $u$ -component of the IEC spectral models is defined as

$$Coh_{i,j} = \exp \left( -a \sqrt{\left( \frac{f r}{\bar{u}_{hub}} \right)^2 + \left( 0.12 \frac{r}{L_c} \right)^2} \right), \quad (50)$$

where  $f$  is the frequency,  $r$  is the distance between points  $i$  and  $j$  on the grid,  $a$  is the coherence decrement,  $\bar{u}_{hub}$  is the mean hub-height wind speed, and  $L_c$  is a coherence scale parameter. For IEC 61400-1 2<sup>nd</sup> ed. [23], the parameters  $a$  and  $L_c$  are

$$\begin{aligned} a &= 8.8 \\ L_c &= 2.45 \min(30\text{m}, HubHt), \end{aligned} \quad (51)$$

where the function  $\min( )$  is the minimum of 30 meters and  $HubHt$ . For IEC 61400-1 3<sup>rd</sup> ed. [20], the parameters are

$$\begin{aligned} a &= 12 \\ L_c &= 5.67 \min(60\text{m}, HubHt). \end{aligned} \quad (52)$$

The IEC 61400-1 standard does not specify coherence for the  $v$  or  $w$  wind-speed components. In TurbSim, the coherence for the  $v$  and  $w$  components of the IEC spectral models is implemented using the identity

$$Coh_{i,j} = \begin{cases} 1 & i = j \\ 0 & i \neq j \end{cases}. \quad (53)$$

### Coherence for Non-IEC Spectral Models

The coherence function for all three of the wind components,  $K = u, v, w$ , for the non-IEC spectral models is defined as

$$Coh_{i,j,K} = \exp \left( -a_K \left( \frac{r}{z_m} \right)^{CohExp} \sqrt{\left( \frac{f r}{u_m} \right)^2 + (b_K r)^2} \right), \quad (54)$$

where  $r$  is the distance between points  $i$  and  $j$ ,  $z_m$  is the mean height of the two points, and  $\bar{u}_m$  is the mean of the wind speeds of the two points (over the entire simulation). The variables  $a$  and  $b$  are the input coherence decrement and offset parameter, respectively, which are defined by the values of the *IncDec1*, *IncDec2*, and *IncDec3* input parameters (for each of the components). Their default values are discussed in the Input File section of this document and are plotted in Figure 13 through Figure 15.

This coherence model is based on the form suggested by Thresher et al. [34] and implemented in the IEC coherence model. The  $\left(\frac{r}{z_m}\right)^{CohExp}$  term has been added to allow users to implement Solari's coherence definition [35]. Note that if  $b = 0$  and  $CohExp = 0$ , this equation also becomes the Davenport coherence model [36].

## Wind (Velocity) Profiles

TurbSim offers users a choice of mean wind (velocity) profiles. The velocity profiles determine the mean  $u$ -component velocity at each height for the length of the simulation. By definition, the mean  $v$ - and  $w$ -component velocities are zero. Wind-direction profiles determine the mean horizontal wind direction at each height. A wind-direction profile is calculated with the low-level jet wind-speed profile, but direction profiles are not calculated with the other velocity profiles.

When computing the mean velocity profile, TurbSim uses the inputs *URef* and *RefHt* as the reference point to calculate the mean velocity at *HubHt*,  $\bar{u}_{hub}$ . The velocities at other heights then are calculated using  $\bar{u}_{hub}$  and *HubHt* as the reference point. Figure 23 shows an example of four different types of mean velocity profiles that were generated using default boundary conditions and *RICH\_NO* = 0.05 with the GP\_LLJ model. For each of the velocity profiles plotted in the figure, *URef* = 12 m/s and *RefHt* = *HubHt* = 90 m.

### Power-Law Wind Profile

The power-law mean velocity profile uses the *PLExp* input parameter to calculate the average wind speed at height  $z$  using the equation

$$\bar{u}(z) = \bar{u}(z_{ref}) \left( \frac{z}{z_{ref}} \right)^{PLExp}, \quad (55)$$

where  $\bar{u}(z)$  is the mean wind speed at  $z$  and  $z_{ref}$  is a reference height above ground where the mean wind speed  $\bar{u}(z_{ref})$  is known.

### Logarithmic Wind Profile

The diabatic (logarithmic) wind profile calculates the average wind speed at height  $z$  using the equation

$$\bar{u}(z) = \bar{u}(z_{ref}) \frac{\ln(z/z_0) - \psi_m}{\ln(z_{ref}/z_0) - \psi_m}, \quad (56)$$

where  $\bar{u}(z)$  is the mean wind speed at  $z$ ,  $z_{ref}$  is a reference height above ground where the mean wind speed is known, and  $Z0$  is the input surface roughness. The function  $\psi_m$  varies with the *RICH\_NO* stability parameter. When *RICH\_NO* = 0 (as is the case with the IEC spectral models),  $\psi_m = 0$ .

### Logarithmic Water Profile

The “water” logarithmic mean velocity profile calculates the average flow speed at height  $z$  using the equation

$$\bar{u}(z) = \frac{UStar}{\kappa} \ln\left(\frac{z}{z_{ref}}\right) + URef, \quad (57)$$

where  $\kappa = 0.41$  is von Karmon’s constant. To specify this type of mean velocity profile use “H2L” (short for “H2O Log”) as the *WindProfileType* input parameter. This velocity profile should always and only be used with the TIDAL spectral model. Note that  $z_{ref}$  should be far from the inertial boundary layer. In general,  $z_{ref}$  should be greater than 10 meters and/or equal to the water depth of the tidal channel.

### IEC Wind Profile

The IEC wind profile was the only wind-speed profile available in SNwind and SNLWIND-3D. This profile uses the power-law wind profile for the wind speeds at heights on the rotor disk and the logarithmic profile for heights not on the rotor disk. For example, if *URef* is specified at a *RefHt* below the rotor disk, the logarithmic profile is used to calculate the *HubHt* mean wind speed. Then the power-law profile would be used with the *HubHt* wind speed to calculate winds across the rotor disk. This profile could cause a discontinuity in the wind profile at the bottom of the rotor disk (this discontinuity would be noticed with tower points and with grids where *GridWidth* < *GridHeight*).

### Low-Level Jet Wind Profile

The low-level jet wind profile is derived from LLLJP 10-minute SODAR measurements and is available with only the GP\_LLJ spectral model. This profile type is unique because it generates both wind-speed and wind-direction profiles. All other wind-profile models use a constant wind direction.

The low-level jet wind-speed profile is defined using Chebyshev polynomials,

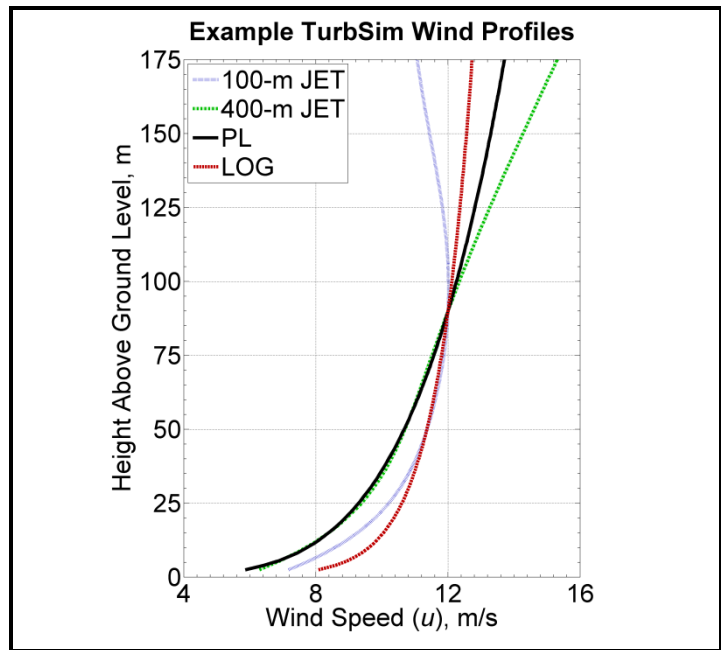


Figure 23. Example wind-speed profiles generated in TurbSim for the GP\_LLJ model using a 90-m hub-height wind speed of 12 m/s, and *RICH\_NO* = 0.05

$$\bar{u}(z) = \sum_{n=0}^{10} c_n \cdot T_n(z), \quad (58)$$

where  $z$  is the height above ground,  $\bar{u}(z)$  is the mean wind speed at height  $z$ ,  $T_n(z)$  is the  $n^{\text{th}}$  order Chebyshev polynomial, and  $c_n$  is a Chebyshev coefficient. The Chebyshev coefficients are derived from LLLJP data and are a linear combination of the jet wind speed,  $\bar{u}_{ZJetMax}$ , and input parameters  $RICH\_NO$  and  $UStar$ :

$$c_n = C_{1,n} \bar{u}_{ZJetMax} + C_{2,n} RICH\_NO + C_{3,n} UStar + C_{4,n}. \quad (59)$$

The coefficients,  $C_{i,n}$ ,  $i = 1, 2, 3, 4$ , are determined by the input parameter  $ZJetMax$ .

The low-level jet wind-direction profile, like the wind-speed profile, is a Chebyshev polynomial with coefficients derived from the same parameters in the LLLJP data. The wind-direction profile is a relative horizontal direction and is always zero at the hub height. The  $HFlowAng$  rotation is added to the relative direction provided from this profile.

Figure 24 plots example jet wind-speed and wind-direction profiles for three different jet heights. The profiles have been generated with  $RICH\_NO = 0.05$ , and an 80-m (hub-height) wind speed of 12 m/s. The  $UStar$  parameter is 0.411 m/s, which is the default for these GP\_LLJ conditions.

## Coherent Structures

For analysis purposes, coherent structures have been defined in terms of CTKE (see Eq. (7) for the CTKE definition). A coherent structure is an event where the 3-s mean CTKE meets a specified threshold value, determined by the mean background levels of a particular site. The event lasts from the time the threshold is first met until the 3-s mean CTKE falls below the threshold value. For the LLLJP data, the threshold chosen was  $2 \text{ m}^2/\text{s}^2$ , and for the LIST and wind-farm data, the threshold chosen was  $5 \text{ m}^2/\text{s}^2$ . Figure 25 gives an example of CTKE measured in the NWTC LIST experiment and shows the detected coherent structures.

The background flow that is produced in TurbSim (i.e., the wind speed data contained in the FF and HH output files) does contain coherent structures, using the definition above. These wind files, however, do not always generate as many coherent structures as observed in the

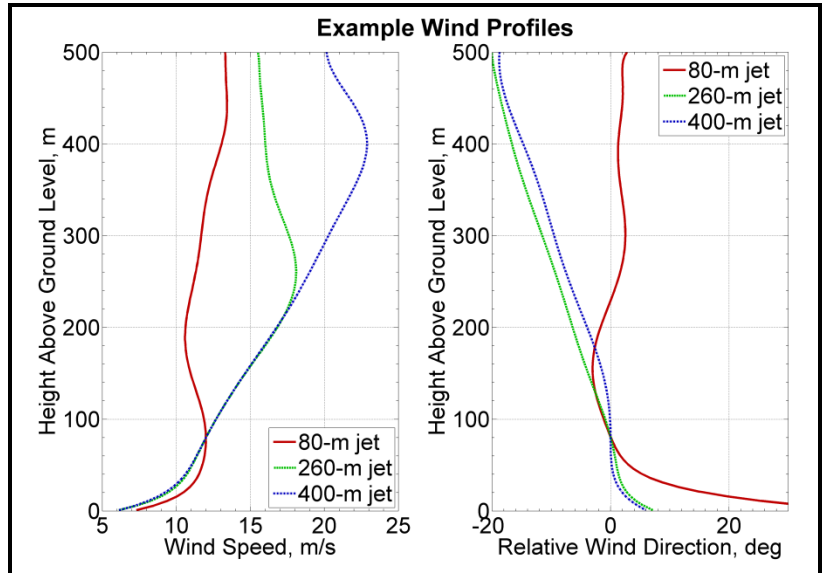


Figure 24. Example jet wind profiles with a 12 m/s wind speed at 80 m and  $RICH\_NO = 0.05$

atmosphere. To obtain more events with realistic spatial-temporal characteristics, sections (in time) of numerical simulations of a Kelvin-Helmholtz billow are added randomly to the background flow when the input parameter  $WrACT$  is “true.” TurbSim generates a coherent turbulence time-step file (“.cts”) with the information describing how to scale the billow and where the events should be added. These events then are superimposed on the background flow in AeroDyn.

An example of the superimposed structures is shown in Figure 26. The black line in the plot shows the 3-s mean CTKE of the background flow at one point on the grid; the green line shows the 3-s mean CTKE of the background with the addition of events in the “.cts” file at the same grid point. It should be noted that the “.cts” files can *decrease* the CTKE of the background as well as *increase* it.

### Adding and Scaling the Coherent Structures

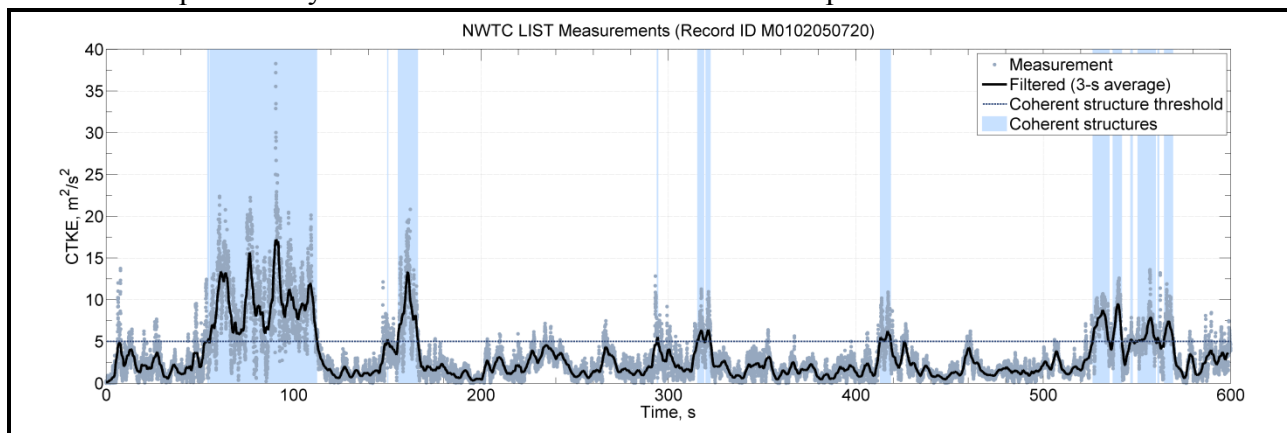
The Kelvin-Helmholtz billow has been broken up into several different pieces, which are a fixed non-dimensional size with non-dimensional velocities. Before adding these pieces to the background flow, they must be scaled in space (through the  $DistScl$  input parameter) and in time to determine the dimensional velocities. TurbSim randomly chooses the start times of the billow pieces from an exponential distribution; the choice of which piece of the billow is inserted at those places is determined from a uniform random distribution.

The coherent structure scaling for the site-specific spectral models has been determined from analysis of sonic anemometer measurements at each of the respective sites, which are described in the Spectral Models section of this guide. The SMOOTH model uses the same scaling as the GP\_LLJ model. Coherent structures are not added to the IEC spectral models.

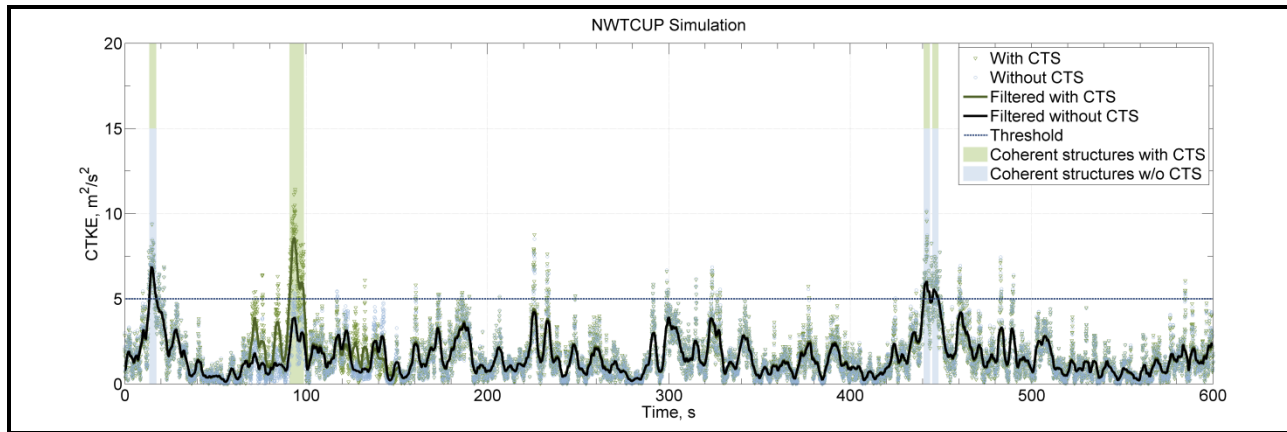
The three non-input parameters for scaling the non-dimensional pieces of the billow and adding them to the background time series are discussed below. A flow chart with these parameters is included in Appendix C.

### Interarrival Times

The interarrival time is the time from the start of one event to the start of the next event. These times are exponentially distributed random variables with rate parameters determined from the



**Figure 25. Coherent structures in a 10-minute period from the NWTC LIST dataset: the time series shows the 3-s mean CTKE (solid black line) crossing the dashed threshold line, which indicates the location of the coherent structures (indicated in blue)**



**Figure 26. Example time series from the NWTcup model: the black line indicates the background wind file; the green shows the addition of events in a coherent time-step file (“.cts”)**

analyzed datasets. For the GP\_LLJ and SMOOTH models, the random distribution is influenced by the height and wind speed,  $\bar{u}_{center}$ , at the center of the billow. For the NWTcup and the wind-farm models, the random distribution is influenced by  $\bar{u}_{center}$  and *RICH\_NO*.

### **Expected Length of Coherent Structures**

The length of coherent structures is the total amount of time that contains coherent structures in a given record. The expected lengths for each of the non-IEC spectral models are selected from a random distribution whose probability density function matches the data from their respective datasets.

TurbSim concatenates extra pieces of the billow to pieces that already have been added to the coherent structure file until the total length of the events is at least the expected length of the coherent structures from the datasets.

### **Peak Coherent Turbulent Kinetic Energy**

The velocities for the coherent events are scaled to achieve a specific peak value in CTKE in the set of events added to the background. The peak CTKE is a function of several different parameters, depending on the spectral model. These parameters include height, *z*; mean wind speed of the background flow at the center of the billow,  $\bar{u}_{center}$ ; shear across the billow (difference in mean wind speed between the top and bottom of the billow),  $\Delta\bar{u}$ ; standard deviation of vertical wind speed at the center of the billow,  $\sigma_{w_{center}}$ ; and input parameters *RICH\_NO* and *UStar*. Some models also include a random component. Table 11 shows which particular parameters are used for each of the non-IEC spectral models.

### **Using Coherent Turbulence Time-Step Files with AeroDyn**

To use the coherent time-step files that TurbSim generates (files with the “.cts” extension), a coherent turbulence parameter input file must be created for AeroDyn’s InflowWind module. This file must have a “.ctp” extension, and the name of this “.ctp” file must be entered on the *WindFile* parameter line in the AeroDyn input file (using v12.57 or later).

See Appendix H in this document for an example of the “.ctp” input file. Do not add or delete lines from the file because AeroDyn assumes parameters are on specific lines. The parameters in the file are discussed below.

**CTSp<sub>ath</sub>: Name of path to coherent turbulence binary data files [-]**

The *CTSp<sub>ath</sub>* parameter is the name of the path that contains the binary data files for the coherent structures, which you must get from the coherent structure archive on the [TurbSim Web site](#) (in folder x90\_i16). This directory must contain files called “Scales.les” and “Scales.dns,” which contain scaling parameters for the two event types, and are used to read and convert normalized 16-bit integer binary data to real numbers. There should also be three folders in this directory, named “u,” “v,” and “w” respectively, containing data for the three wind components. Each of these three directories contains files named something like “u\_i16\_xxxx.les.”

**CTTSfile: Name of TurbSim CTS file [-]**

The parameter *CTTSfile* is the name of the coherent time-step file generated by TurbSim. It has a “.cts” extension. This file name must be specified relative to the directory from which AeroDyn will be run.

**CTbackgr: Name of TurbSim background FF file [-]**

The parameter *CTbackgr* is the name of the background turbulence file. This should be the FF wind file with the “.wnd” or “.bts” extension that was generated at the same time the “.cts” file was created. This file name also must be specified relative to the directory from which AeroDyn will be run. AeroDyn automatically looks for the “.sum” summary file that goes with a binary “.wnd” file.

**CT\_DF\_Y: Decimation factor in the Y direction [-]**

The *CT\_DF\_Y* parameter is used for decimating the binary coherent turbulence data in the horizontal, *Y*, direction. Enter the horizontal decimation factor: A value of 1 uses every point in the *Y* direction, 2 uses every other point, etc. It is recommended that you always use the entire grid (i.e., *CT\_DF\_Y* = 1).

**Table 11. Coherent Structure Peak CTKE Scaling**

<i>TurbModel</i>	Predictors of Peak CTKE	Random Component?
GP_LLJ/SMOOTH	$RICH\_NO, \Delta \bar{u}, UStar, z$	Yes
NWTCUP	$RICH\_NO, \Delta \bar{u}, \sigma_{w_{center}}, \bar{u}_{center}$	Yes
WF_UPW	$RICH\_NO, \Delta \bar{u}, \sigma_{w_{center}}, \bar{u}_{center}$	No
WF_07D	$RICH\_NO, \Delta \bar{u}, \sigma_{w_{center}}, UStar$	Yes
WF_14D	$RICH\_NO, \Delta \bar{u}, \sigma_{w_{center}}, \bar{u}_{center}$	No



### ***CT\_DF\_Z: Decimation factor in the Z direction [-]***

The *CT\_DF\_Z* parameter is used for decimating the binary coherent turbulence data in the vertical, *Z*, direction. Enter the vertical decimation factor: A value of 1 uses every point in the *Z* direction, 2 uses every other point, etc. It is recommended that you always use the entire grid (i.e., *CT\_DF\_Z* = 1).

### **Suggestions for Generating Coherent Turbulent Structures**

Effort has been made in TurbSim to randomize the occurrence and scaling of coherent event structures that occur in natural, nocturnal boundary layer flows. Simulations that generate coherent turbulence time-step files have up to 10 degrees of stochastic freedom—in addition to the random phases associated with each frequency at each grid point and wind component—and are designed to give some feel of the expected variability in the atmosphere. Because of the degree of variability, using more than 30 different random seeds<sup>2</sup> for a specific set of boundary conditions is recommended.

To test the effects of a coherent structure (KH billow), we recommend using the “KHTEST” option in the *IECturbc* input parameter with the NWTCUP spectral model. This test function superimposes one intense coherent event in the middle of the output time series, reducing the number of stochastic degrees of freedom to no more than two (plus the random phases). The gradient Richardson number (*RICH\_NO*) and wind shear (*PLExp*) of the background flow are overwritten, and TurbSim uses fixed values to scale the LES-type event. This test function is designed to generate intense turbulence, and does not necessarily reflect the variability for given boundary conditions.

The choice of the gradient Richardson number and hub wind speed largely control the impact of coherent structures on turbine response. It is recommended that at least one series of runs be made at rated wind speed and a Richardson number between 0.02 and 0.05. Further discussion on the impact of coherent turbulent structures on wind turbines is found in [37].

### **Warnings**

- AeroDyn v12.57 or a later version is required to read TurbSim files correctly.
- If you compile AeroDyn, you must use the compiler option “/assume:byterecl” to read the TurbSim coherent structures binary files correctly. If you use ADAMS2AD [38], be sure to use v12.17 or later so that this compiler option is set.
- Hub-height time series from HH wind files and FF wind files do not have events happening at the same time because AeroDyn shifts the FF files (see Figure 17).
- Because of the way the FFT routine works, extra time must be added to the analysis time to get the FFT to run efficiently. Due to this plus the fact that the output time could be shorter than the analysis time, the mean wind speed for the portion of the run actually used could be different from what was specified in the input file.

---

<sup>2</sup> As a general rule of thumb, the number 30 is the dividing line between large and small sample statistics.

- The statistics calculated in the summary file are based on the complete time series generated (the analysis time plus any extra time added for the FFT calculations). Because the output time can be less than the analysis time, these statistics might differ from what can be calculated from the output files.
- Be cautious when using mean flow angle inputs with full-field grids for AeroDyn. AeroDyn marches FF grids through the turbine along the *X*-axis at the mean hub-height wind speed, regardless of the flow angles. This can give strange results if the mean flow angles are not small.

## Limitations

- The GP\_LLJ spectral model is estimated to be applicable up to a height of 230 m.
- The SMOOTH spectral model and the coherent turbulence time-step files are both currently estimated to be applicable up to a height of 120 m.
- The NWTCUP spectral model is estimated to be applicable up to heights of 120 m.
- The wind farm spectral models (WF\_UPW, WF\_07D, and WF\_14D) are valid only up to heights of about 50 m.

## Possible Future Enhancements

- Add options for user-defined spectra and/or user-defined coherence.
- Add the Mann model.
- Add other site-specific models if data becomes available.

## Caveats

NREL makes no guarantees about the usability or accuracy of TurbSim, which is essentially a beta code. NREL does not have the resources to provide full support for this program.

## Disclaimer

To view the software disclaimer, please visit the NREL Web site:  
<http://wind.nrel.gov/designcodes/disclaimer.html>.

## Feedback

If you have problems with TurbSim, please contact Bonnie Jonkman. We will respond to your needs if time and resources permit, but please do not expect an immediate response. Send comments or bug reports to:

Bonnie J. Jonkman  
NWTC/3811  
National Renewable Energy Laboratory  
15013 Denver West Parkway  
Golden, CO 80401-3393  
United States of America  
E-mail: [bonnie.jonkman@nrel.gov](mailto:bonnie.jonkman@nrel.gov)  
Phone: +1 (303) 384-6907  
Fax: +1 (303) 384-6901  
Web site: <http://wind.nrel.gov/designcodes>

## References

- [1] Laino, D. J.; Hansen, A.C. *User's Guide to the Wind Turbine Dynamics Aerodynamics Computer Software AeroDyn*. Salt Lake City, UT: Windward Engineering, LC, December 2002. <http://wind.nrel.gov/designcodes/simulators/aerodyn/>. Accessed August 25, 2009.
- [2] Jonkman, J. M.; Buhl Jr., M. L. *FAST User's Guide*. NREL/EL-500-29798. Golden, CO: National Renewable Energy Laboratory, August 2005. <http://wind.nrel.gov/designcodes/simulators/fast/>. Accessed August 25, 2009.
- [3] MSC Software. 2005. *MSC.ADAMS®*. MSC Software Corporation, Santa Ana, CA. <http://www.mssoftware.com/>. Accessed August 25, 2009.
- [4] Veers, P.S. *Three-Dimensional Wind Simulation*. SAND88-0152. Albuquerque, NM: Sandia National Laboratories, March 1988.
- [5] Kelley, N.D. *Full Vector (3-D) Inflow Simulation in Natural and Wind Farm Environments Using an Expanded Version of the SNLWIND (VEERS) Turbulence Code*. NREL/TP-442-5225. Golden, CO: National Renewable Energy Laboratory, November 1992.
- [6] Bossanyi, E.A. *GH Bladed Version 3.6 User Manual*. Document 282/BR/010 Issue 12. Garrad Hassan and Partners Limited, 2003.
- [7] Buhl, M.L. Jr. *SNwind User's Guide*. NREL/EL-500-30121. Golden, CO: National Renewable Energy Laboratory, October 2001.
- [8] Swarztrauber, P.N. *FFTPACK Version 4.1*. Boulder, CO: National Center for Atmospheric Research, November 1988. <http://www.scd.ucar.edu/softlib/FFTPACK.html>. Accessed August 25, 2009.
- [9] Kelley, N.D.; Jonkman, B.J. *Overview of the TurbSim Stochastic Inflow Turbulence Simulator Version 1.21*. NREL/TP-500-41137. National Renewable Energy Laboratory, Golden, CO, March 2007.
- [10] Buhl, Jr. M.L. *Installing NWTTC Design Codes on PCs Running Windows NT®*. NREL/EL-500-29384. Golden, CO: National Renewable Energy Laboratory, December 2000.
- [11] The MathWorks. 2008. *MATLAB®*. Natick, MA. <http://www.mathworks.com/>. Accessed August 25, 2009.
- [12] Anderson, E.; Bai, Z.; Bischof, C.; Blackford, S.; Demmel, J.; Dongarra, J.; Du Croz, J.; Greenbaum, A.; Hammarling, S.; McKenney, A.; Sorensen, D. *LAPACK User's Guide*, 3<sup>rd</sup> edition. Philadelphia, PA: Society for Industrial and Applied Mathematics, August 1999. <http://www.netlib.org/lapack>. Accessed August 25, 2009.
- [13] Lawson, C.L.; Hanson, R.J.; Kincaid, D.; Krogh, F.T. "Basic Linear Algebra Subprograms for FORTRAN usage." *ACM Trans. Math. Soft.*, Vol. 5, September 1979; pp. 308-323.

- [14] Dongarra, J.J.; Du Croz, J.; Hammarling, S.; and Hanson, R.J. "An extended set of FORTRAN Basic Linear Algebra Subprograms." *ACM Trans. Math. Soft.*, Vol. 14, March 1988; pp. 1-17.
- [15] Meissner, Loren P. (August 1995) "ranlux.f90." <http://flash.uchicago.edu/~tomek/htmls/refs/ranlux.f90.html>. Accessed October 19, 2005. Copy of document on file with the author.
- [16] Buhl, M.L., Jr. "NWTC Subroutine Library" *NWTC Design Codes*, [http://wind.nrel.gov/designcodes/miscellaneous/nwtc\\_subs](http://wind.nrel.gov/designcodes/miscellaneous/nwtc_subs). Last modified 18-Jan-2008; Accessed August 25, 2009.
- [17] L'ecuyer, P. "Efficient and Portable Combined Random Number Generators." *Communications of the ACM*, Vol. 31, June 1988; pp. 742-751.
- [18] Lüscher, M. "A portable high-quality random number generator for lattice field theory simulations." *Computer Physics Communications*, Vol. 79, February 1994; pp. 100-110.
- [19] James, F. "RANLUX: A Fortran implementation of the high-quality pseudorandom number generator of Lüscher." *Computer Physics Communications*, Vol. 79, February 1994; pp. 111-114.
- [20] IEC 61400-1 "Wind turbines-Part 1: Design requirements." 3<sup>rd</sup> edition. Geneva, Switzerland: International Electrotechnical Commission, August 2005.
- [21] IEC 61400-2 "Wind turbines-Part 2: Design requirements for small wind turbines." 2<sup>nd</sup> edition. Geneva, Switzerland: International Electrotechnical Commission, March 2006.
- [22] IEC 61400-3 "Wind turbines-Part 3: Design requirements for offshore wind turbines." Draft 1<sup>st</sup> edition. Geneva, Switzerland: International Electrotechnical Commission, January 2006.
- [23] IEC 61400-1 "Wind turbine generator systems-Part 1: Safety requirements." 2<sup>nd</sup> edition. Geneva, Switzerland: International Electrotechnical Commission, 1999.
- [24] Panofsky, H.A.; Dutton, J.A. *Atmospheric Turbulence: Models and Methods for Engineering Applications*. New York: Wiley-Interscience, 1984. 397 pp.
- [25] Dutton, J.A.; Panofsky, H.A.; Larko, D.; Shirer, H.N.; Stone, G.; Vilaro, M. *Statistics of wind fluctuations over complex terrain*. Report No. DOE/ET/20560-1. University Park, PA: Pennsylvania State University, Department of Meteorology, October 1979.
- [26] ESDU. Report No. 85020. *Characteristics of atmospheric turbulence near the ground, Part II: Single point data for strong winds (neutral atmosphere)*. London: Engineering Sciences Data Unit, April 1993.
- [27] Højstrup, J. "Velocity Spectra in the Unstable Planetary Boundary Layer." *Journal of the Atmospheric Sciences*, Vol. 39, October 1982; pp. 2239-2248.

- [28] Olesen, H.R.; Larsen, S.E.; Højstrup, J. “Modeling Velocity Spectra in the Lower Part of the Planetary Boundary Layer.” *Boundary-Layer Meteorology*, Vol. 29, July 1984; pp. 285-312.
- [29] Kelley, N.; Hand, M.; Larwood, S.; and McKenna, E. *The NREL Large-Scale Turbine Inflow and Response Experiment – Preliminary Results*. NREL/CP-500-30917. Golden, CO: National Renewable Energy Laboratory, January 2002.
- [30] Kelley, N.D.; Shirazi, M.; Jager, D.; Wilde, S.; Adams, J.; Buhl, M.; Sullivan, P.; Patton, E. *Lamar Low-Level Jet Project Interim Report*. NREL/TP-500-34593. Golden, CO: National Renewable Energy Laboratory, January 2004.
- [31] Kelley, N.D.; Wright, A.D. *A Comparison of Predicted and Observed Turbulence Wind Fields Present in Natural and Internal Wind Park Environments*. NREL/TP-257-4508. Golden, CO: National Renewable Energy Laboratory, October 1991.
- [32] Tangler, J.; Smith, B.; Jager, D.; Olsen, T. *SERI Thin-Airfoil Blade Atmospheric Performance Test: Final Results* NREL/TP-257-4076, Golden, CO: National Renewable Energy Laboratory, September 1990.
- [33] Thomson, J.; Polagye, B.; Durgesh, V.; Richmond, M.; “Measurements of Turbulence at Two Tidal Power Sites in Puget Sound, WA (USA)”, *Journal of Oceanic Engineering*, July 2012. doi: 10.1109/JOE.2012.2191656
- [34] Thresher, R.W.; Holley, W.E.; Smith, C.E.; Jafarey, N.; and Lin, S.-R. *Modeling the Response of Wind Turbines to Atmospheric Turbulence*. Report No. RL0/2227-81/2. Corvallis, OR: Oregon State University, Department of Mechanical Engineering, August 1981.
- [35] Solari, G. “Turbulence Modeling for Gust Loading,” *ASCE Journal of Structural Engineering*, Vol 113 (7), July 1987; pp. 1550-1569.
- [36] Davenport, A.G. “The Spectrum of Horizontal Gustiness Near the Ground in High Winds,”. *Quarterly Journal of the Royal Meteorological Society*, Vol. 87, 1961; pp. 194-211.
- [37] Kelley, N.D.; Jonkman, B.J.; Scott, G.N.; Bialasiewicz, J.T.; Redmond, L.S. *The Impact of Coherent Turbulence on Wind Turbine Aeroelastic Response and Its Simulation*. NREL/CP-500-38074. Golden, CO: National Renewable Energy Laboratory, August 2005.
- [38] Laino, D.J.; Hansen, A.C. *User’s Guide to the Computer Software Routines AeroDyn Interface for ADAMS®*. Salt Lake City, UT: Windward Engineering, LC, September 2001. <http://wind.nrel.gov/designcodes/simulators/adams2ad/>. Accessed August 25, 2009.

## Appendix A: Sample TurbSim Input File

```

TurbSim Input File. Valid for TurbSim v1.50, 4-Aug-2009

-----Runtime Options-----
2318573  RandSeed1  - First random seed (-2147483648 to 2147483647)
RANLUX   RandSeed2  - Second random seed for intrinsic pRNG, or other pRNG: "RanLux" or "RNSNLW"
False    WrBHHTP   - Output HH turbulence parameters in GenPro-binary form? (Generates RootName.bin)
False    WrFHHTP   - Output HH turbulence parameters in formatted form? (Generates RootName.dat)
False    WrADHH   - Output hub-height time-series data in AeroDyn form? (Generates RootName.hh)
False    WrADFF   - Output FF time-series data in TurbSim/AeroDyn form? (Generates Rootname.bts)
True     WrBLFF   - Output FF time-series data in BLADED/AeroDyn form? (Generates RootName.wnd)
False    WrADTWR   - Output tower time-series data? (Generates RootName.twr)
False    WrFMFFF   - Output FF time-series data in formatted (readable) form? (RootName.u, .v, .w)
True     WrACT    - Output coherent turbulence time steps in AeroDyn form? (Generates RootName.cts)
True     Clockwise - Clockwise rotation looking downwind? (Used only for FF binary files w/ BLADED)
0        ScaleIEC - Scale IEC turbulence models to exact target std deviation? [0=none;1=hub;2=all]

-----Turbine/Model Specifications-----
13       NumGrid_Z - Vertical grid-point matrix dimension
13       NumGrid_Y - Horizontal grid-point matrix dimension
0.05     TimeStep  - Time step [s]
630      AnalysisTime- Length of analysis time series [s] (program will add time if necessary)
630      UsableTime - Usable length of output time series [s] (program adds GridWidth/MeanHHWS seconds)
84.30    HubHt    - Hub height [m] (should be > 0.5*GridHeight)
80.00    GridHeight - Grid height [m]
80.00    GridWidth - Grid width [m] (should be >= 2*(RotorRadius+ShaftLength))
0        VFlowAng - Vertical mean flow (uptilt) angle [degrees]
0        HFlowAng - Horizontal mean flow (skew) angle [degrees]

-----Meteorological Boundary Conditions-----
"SMOOTH" TurbModel  - Turbulence model (IECKAI, IECVKM, GP_LLJ, NWTCP, SMOOTH, WF_UPW, WF_07D, WF_14D)
"1-ED2"  IECstandard - Number of the IEC standard (61400-x, x=1,2,3) with optional 61400-1 ed. number
"A"      IECturbc   - IEC turbulence characteristic ("A", "B", "C" or TI in %) or KHTEST
"NTM"    IEC_WindType- IEC turbulence type ("NTM", "xETM", "xEWM1", or "xEWM50" for x=class 1, 2, or 3)
default  ETMc      - IEC Extreme turbulence model "c" parameter [m/s] (or "default")
"IEC"    ProfileType - Wind profile type ("JET"=Low-level jet, "LOG", "PL"=power law, "IEC", "default")
84.30    RefHt    - Height of the reference wind speed [m]
18.2     URef     - Mean wind speed at the reference height [m/s]
450      ZJetMax  - Height of the low-level jet [m] (70-490 m or "default", only for "JET" profile)
default  PLExp    - Power law exponent (or "default")
default  Z0      - Surface roughness length [m] (or "default")

-----Non-IEC Meteorological Boundary Conditions-----
default  Latitude - Site latitude [degrees] (or "default")
0.05     RICH_NO  - Gradient Richardson number
default  UStar    - Friction or shear velocity [m/s] (or "default")
default  ZI      - Mixing layer depth [m] (or "default")
default  PC_UW   - Mean u'w' Reynolds stress (or "default")
default  PC_UV   - Mean u'v' Reynolds stress (or "default")
default  PC_VW   - Mean v'w' Reynolds stress (or "default")
default  InCDec1 - U-component coherence parameters ("a b" in quotes or "default")
default  InCDec2 - V-component coherence parameters ("a b" in quotes or "default")
default  InCDec3 - W-component coherence parameters ("a b" in quotes or "default")
default  CohExp  - Coherence exponent (or "default")

-----Coherent Turbulence Scaling Parameters-----
"M:\coh_events\eventdata" CTEventPath - Name of the path where event data files are located
"Random" CTEventFile - Type of event files ("LES", "DNS", or "RANDOM")
True     Randomize - Randomize the disturbance scale and locations? (true/false)
1.0     DistScl  - Disturbance scale (ratio of wave height to rotor disk).
0.5     CTly    - Fractional location of tower center from right to L of dataset looking downwind
0.5     CTLz    - Fractional location of hub height from the bottom of the dataset
30.0    CTStartTime - Minimum start time for coherent structures in RootName.cts [s]

=====
NOTE: Do not add or remove any lines in this file!
=====

```

Figure A-1. Sample TurbSim input file

## Appendix B: TurbSim Quick-Start Guidelines for IEC Turbulence

To generate IEC-type turbulence, many of the parameters in the TurbSim input file can be ignored. Figure B-1 shows a TurbSim input file set up to generate IEC 61400-1 3<sup>rd</sup> ed., category “B” turbulence for the NTM using the Kaimal model. It creates a FF Bladed-style “.wnd” file containing 630 seconds of usable data, using a time step of 0.05 s.

All of the unused parameters have been crossed out in Figure B-1. The parameters in black typically do not need to be changed. The input parameters that typically might have to be changed are mentioned below, along with suggestions for typical values. The Input File section of this guide describes the parameters in more detail. The parameters in *blue italics* in Figure B-1 should be changed based on the particular turbine for which the wind field is being generated:

- *ScaleIEC*: Change this parameter to the type of scaling desired. If you are unsure, use 0.
- *NumGrid\_Z*: The number of vertical grid points should be set so there is sufficient vertical grid resolution. A typical value is an odd integer that is close to the *GridHeight* divided by the mean chord of the turbine’s blades.
- *NumGrid\_Y*: The number of lateral grid points should be set so there is sufficient lateral grid resolution. A typical value is an odd integer that is close to the *GridWidth* divided by the mean chord of the turbine’s blades.
- *HubHt*: This is the hub height in meters of the turbine for which the turbulence is being generated.
- *GridHeight*: The grid height (in meters) typically is 10% larger than the turbine rotor diameter. It must be larger for turbines that have significant displacements.
- *GridWidth*: The grid width (in meters) typically is the same as *GridHeight*.
- *IECturbc*: The turbulence category should be “A,” “B,” or “C,” depending on the desired 61400-1 category. Category “A” is the most turbulent.
- *RefHt*: The reference height is the height (in meters) where the input wind speed is defined. It is typically the same as *HubHt*.

The parameters in **bold red** in Figure B-1 typically are changed for each case when running design load cases:

- *RandSeed1*: The random seed, which initializes the pseudo-random number generator, should be a different number for each simulation. For each case, several different seeds should be used, keeping *all* other input parameters constant.
- *IEC\_WindType*: This is the wind condition for the (turbulent) IEC load cases. It often is NTM. For other conditions, see Table 5 of this guide.
- *URef*: This is the reference wind speed (in meters per second) at the *RefHt*. It typically ranges from cut-in to cut-out in 2 m/s increments.



TurbSim Input File. Valid for TurbSim v1.50, 4-Aug-2009

```
-----Runtime Options-----
1234567 RandSeed1 - First random seed (-2147483648 to 2147483647)
RANLUX RandSeed2 - Second random seed for intrinsic pRNG, or other pRNG: "RanLux" or "RNSNLW"
False WrBHHTP - Output HH turbulence parameters in GenPro-binary form? (Generates RootName.bin)
False WrFHHTP - Output HH turbulence parameters in formatted form? (Generates RootName.dat)
False WrADHH - Output hub-height time-series data in AeroDyn form? (Generates RootName.hh)
False WrADFF - Output FF time-series data in TurbSim/AeroDyn form? (Generates Rootname.bts)
True WrBLFF - Output FF time-series data in BLADED/AeroDyn form? (Generates RootName.wnd)
False WrADTWR - Output tower time-series data? (Generates RootName.twr)
False WrFMTEFF - Output FF time-series data in formatted (readable) form? (RootName.u, .v, .w)
False WrACT - Output coherent turbulence time steps in AeroDyn form? (Generates RootName.cts)
True Clockwise - Clockwise rotation looking downwind? (Used only for FF binary files w/ BLADED)
0 ScaleIEC - Scale IEC turbulence models to exact target std deviation? [0=none;1=hub;2=all]

-----Turbine/Model Specifications-----
13 NumGrid_Z - Vertical grid-point matrix dimension
13 NumGrid_Y - Horizontal grid-point matrix dimension
0.05 TimeStep - Time step [s]
630 AnalysisTime - Length of analysis time series [s] (program will add time if necessary)
630 UsableTime - Usable length of output time series [s] (program adds GridWidth/MeanHHWS seconds)
84.30 HubHt - Hub height [m] (should be > 0.5*GridHeight)
80.00 GridHeight - Grid height [m]
80.00 GridWidth - Grid width [m] (should be >= 2*(RotorRadius+ShaftLength))
0 VFlowAng - Vertical mean flow (uptilt) angle [degrees]
0 HFlowAng - Horizontal mean flow (skew) angle [degrees]

-----Meteorological Boundary Conditions-----
"IECKAI" TurbModel - Turbulence model (IECKAI, IECVKM, GP_LLJ, NWTICUP, SMOOTH, WF_UPW, WF_07D, WF_14D)
"1-ED3" IECstandard - Number of the IEC standard (61400-x, x=1,2,3) with optional 61400-1 ed. #
"B" IECturbc - IEC turbulence characteristic ("A", "B", "C" or TI in %) or KHTEST
"NTM" IEC_WindType - IEC turbulence type ("NTM", "xETM", "xEWM1", or "xEWM50" for x=class 1, 2, or 3)
default ETMc - IEC Extreme turbulence model "c" parameter [m/s] (or "default")
"PL" ProfileType - Wind profile type ("JET"=Low-level jet, "LOG", "PL"=power law, "IEC", "default")
84.30 RefHt - Height of the reference wind speed [m]
18.2 URef - Mean wind speed at the reference height [m/s]
default ZJetMax - Height of the low-level jet [m] (70-490 m or "default", only for "JET" profile)
default PLExp - Power law exponent (or "default")
default Z0 - Surface roughness length [m] (or "default")

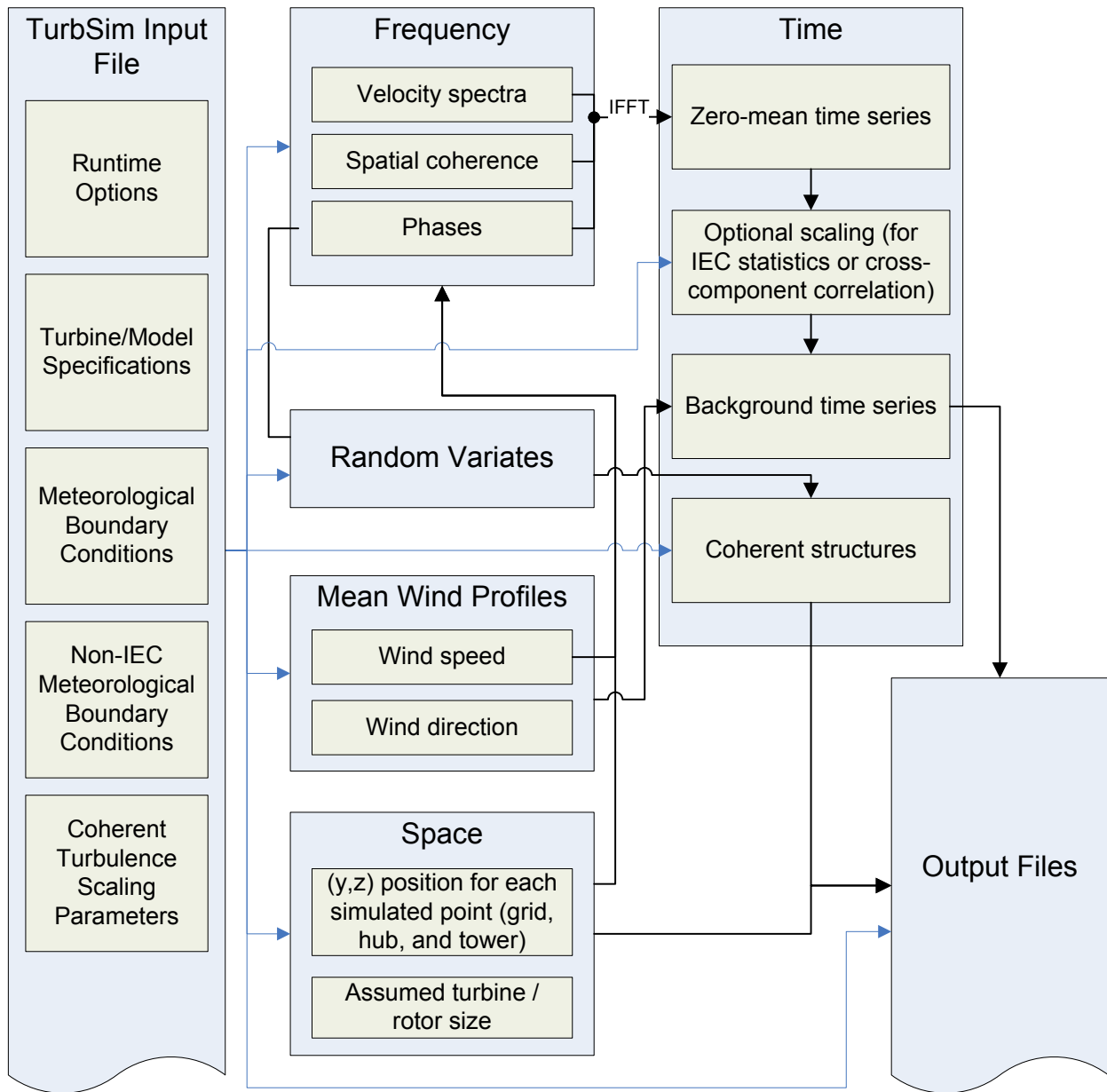
-----Non IEC Meteorological Boundary Conditions-----
default Latitude - Site latitude [degrees] (or "default")
0.00 RICH_NO - Gradient Richardson number
default UStar - Friction or shear velocity [m/s] (or "default")
default ZI - Mixing layer depth [m] (or "default")
default PC_UW - Mean u'w' Reynolds stress (or "default")
default PC_UV - Mean u'v' Reynolds stress (or "default")
default PC_VW - Mean v'w' Reynolds stress (or "default")
default InCDec1 - U component coherence parameters ("a b" in quotes or "default")
default InCDec2 - V component coherence parameters ("a b" in quotes or "default")
default InCDec3 - W component coherence parameters ("a b" in quotes or "default")
default CohExp - Coherence exponent (or "default")

-----Coherent Turbulence Scaling Parameters-----
"M:\eventdata" CTEventPath - Name of the path where event data files are located
"Random" CTEventFile - Type of event files ("LES", "DNS", or "RANDOM")
True Randomize - Randomize the disturbance scale and locations? (true/false)
-1.0 DistSel - Disturbance scale (ratio of wave height to rotor disk).
-0.5 CTly - Fractional location of tower center from R to L of dataset looking downwind
-0.5 CTlz - Fractional location of hub height from the bottom of the dataset.
30.0 CTStartTime - Minimum start time for coherent structures in RootName.cts [s]

=====
NOTE: Do not add or remove any lines in this file!
```

**Figure B-1. Sample TurbSim input file for IEC turbulence: parameters shown in blue should be changed based on the turbine configuration; parameters shown in red should be changed for each load case and simulation.**

## Appendix C: Flow Charts



**Figure C-1. Overview of the TurbSim simulation method; blue lines indicate processes influenced by input-file parameters; black lines indicate internal variables and processes**

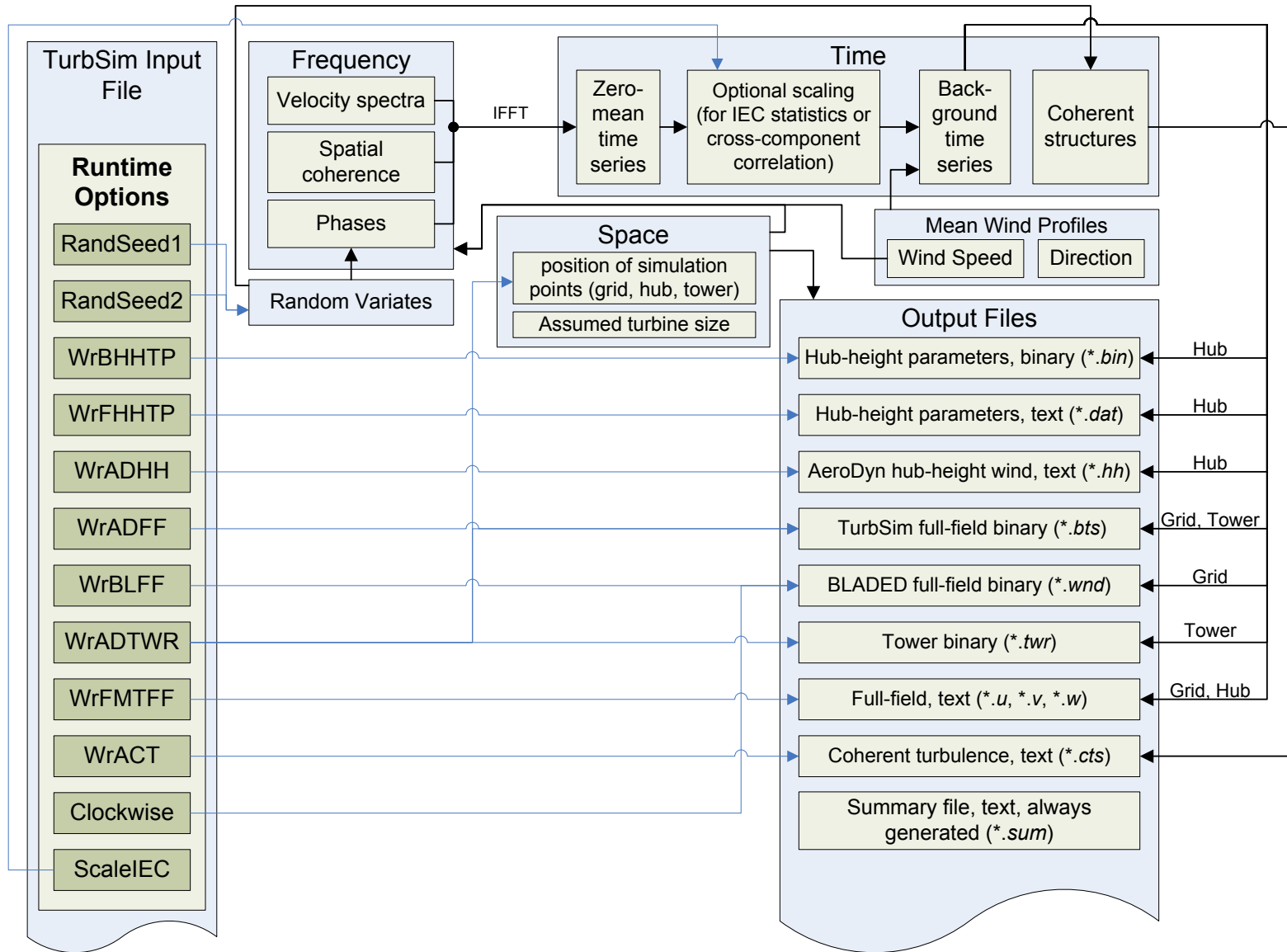


Figure C-2. Parameters in the Runtime Options section of the input file

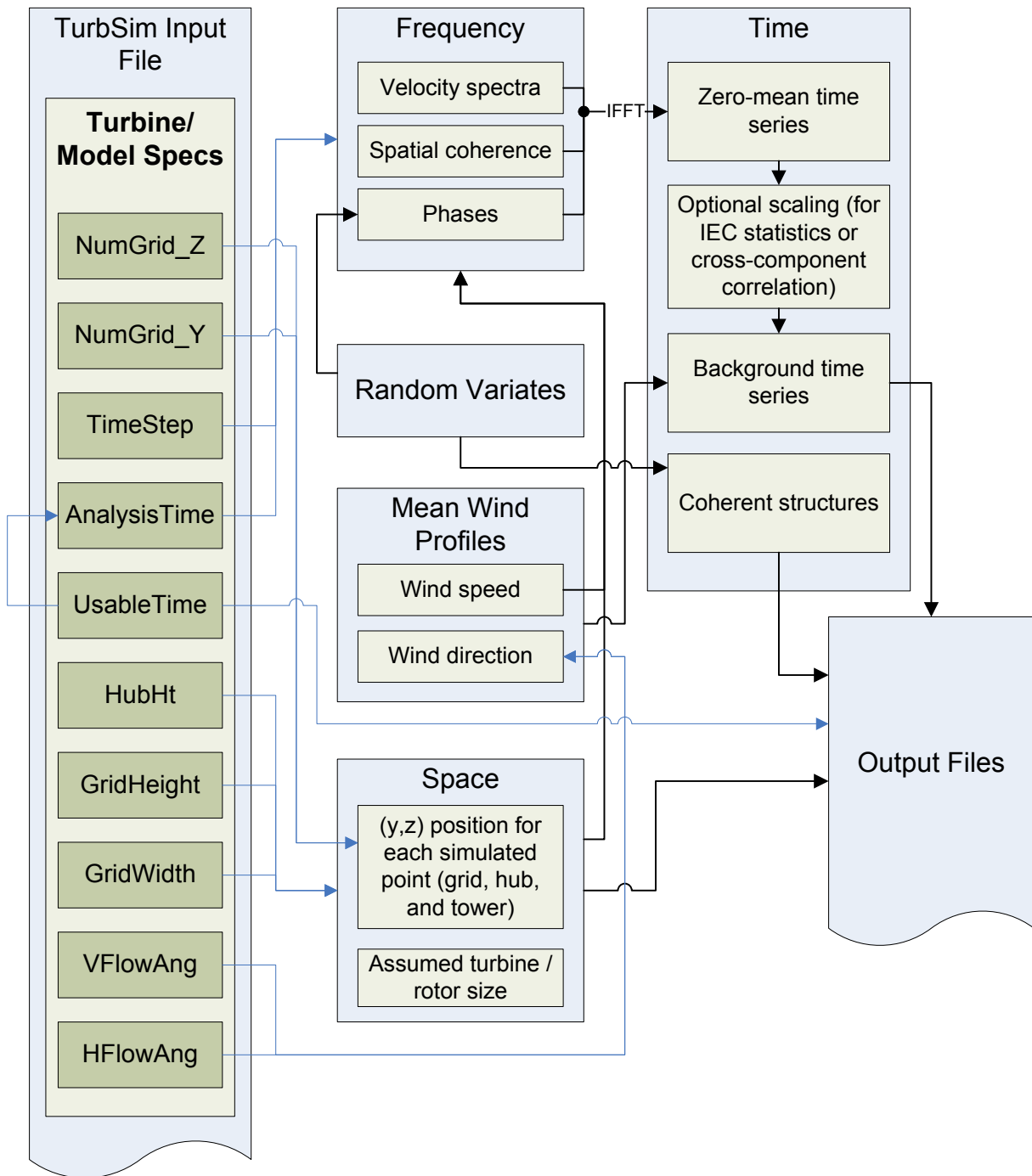


Figure C-3. Parameters in the Turbine/Model Specifications section of the TurbSim input file

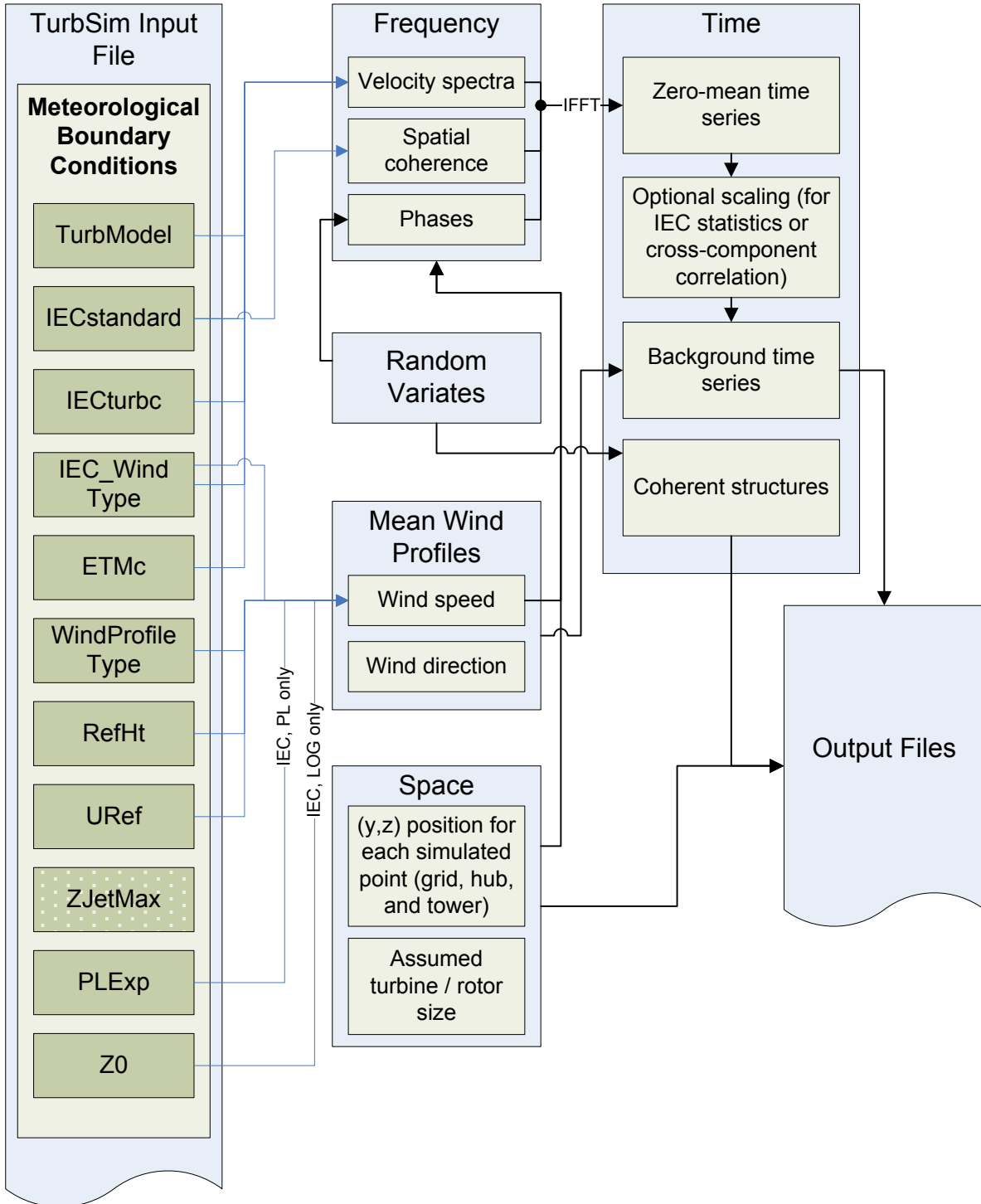


Figure C-4. Parameters in the Meteorological Boundary Conditions section of the TurbSim input file (for IECKAI and IECVKM models only)

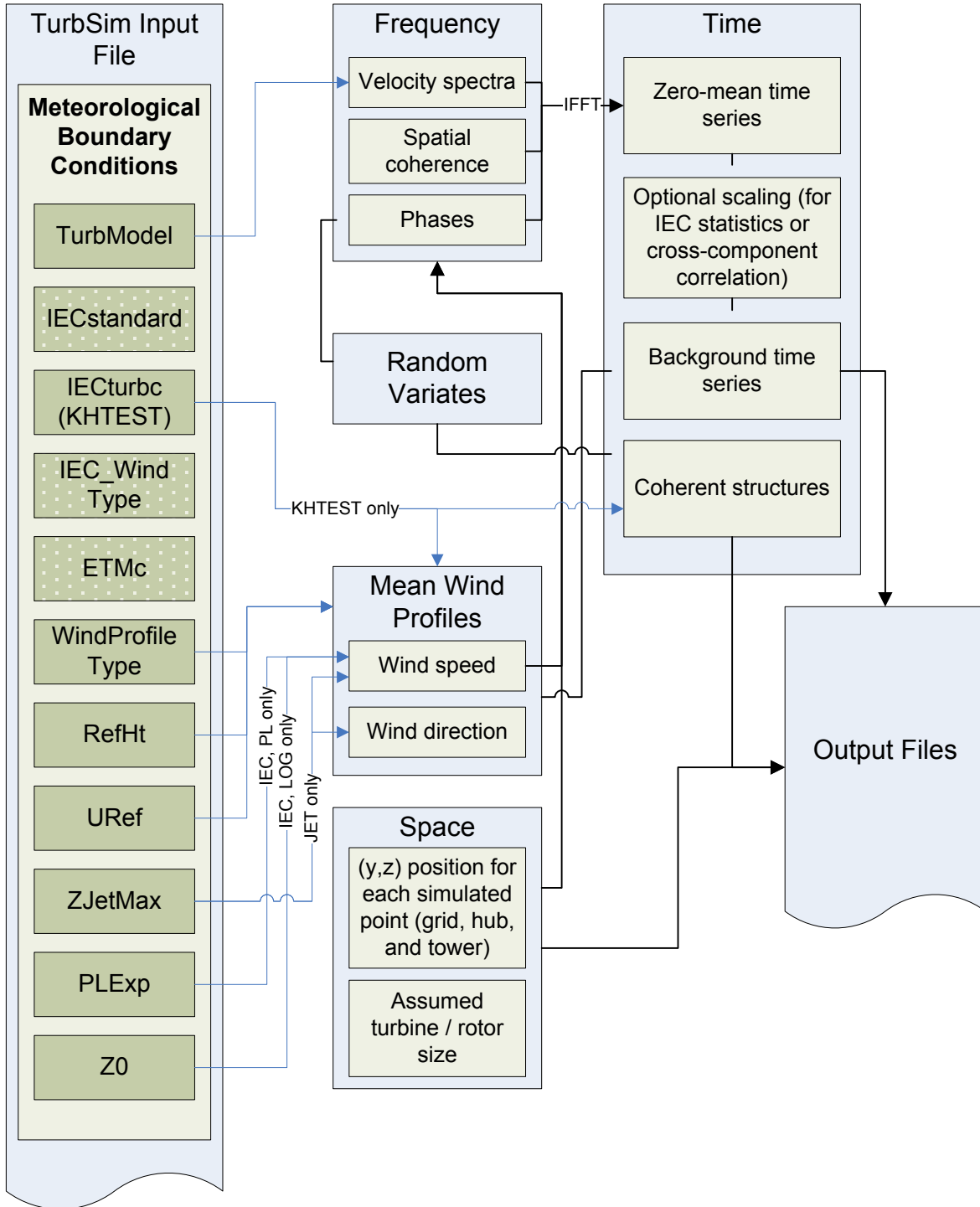


Figure C-5. Parameters in the Meteorological Boundary Conditions section of the TurbSim input file (for models other than IECKAI and IECVKM)

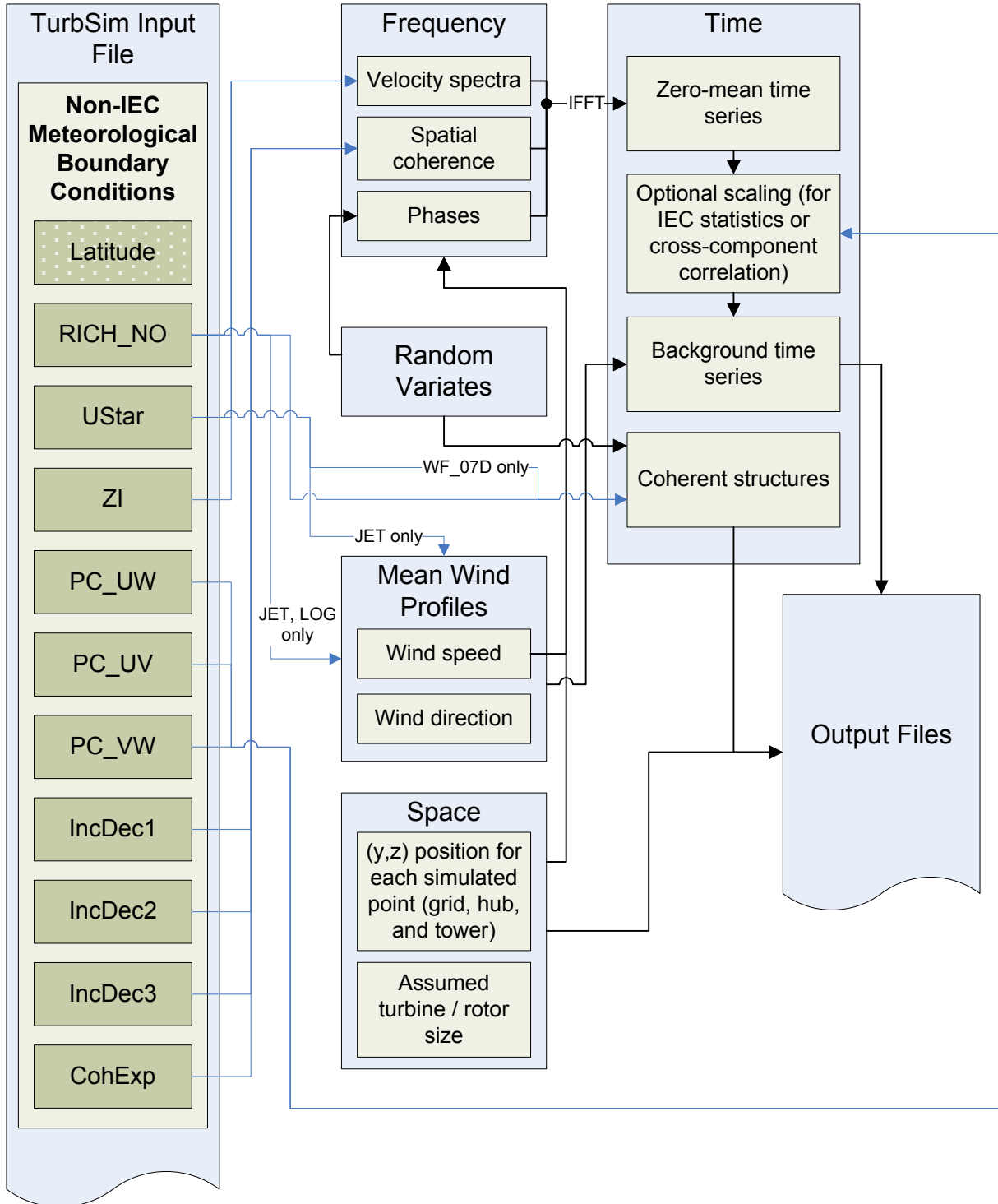


Figure C-6. Parameters in the Non-IEC Meteorological Boundary Conditions section of the TurbSim input file

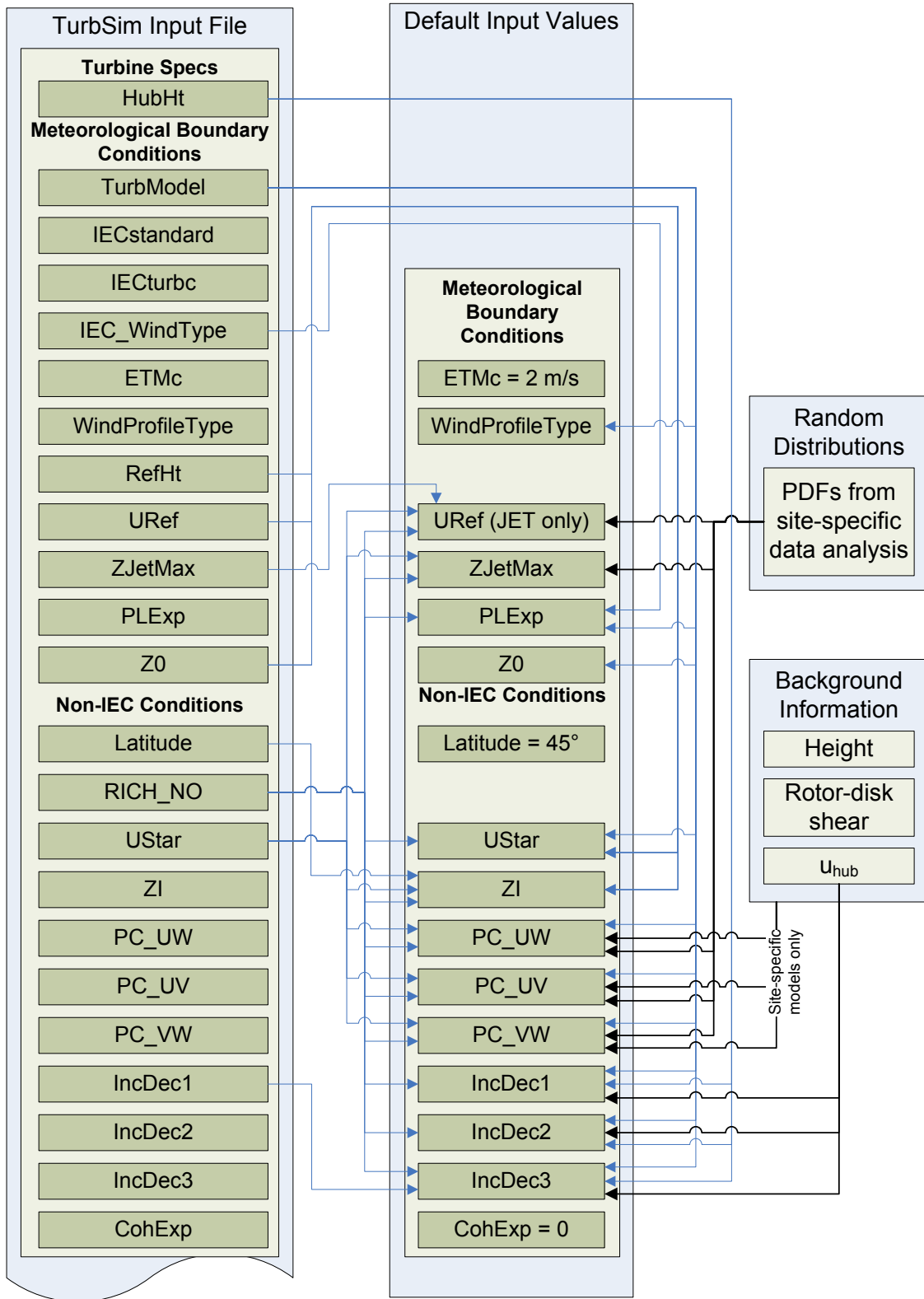
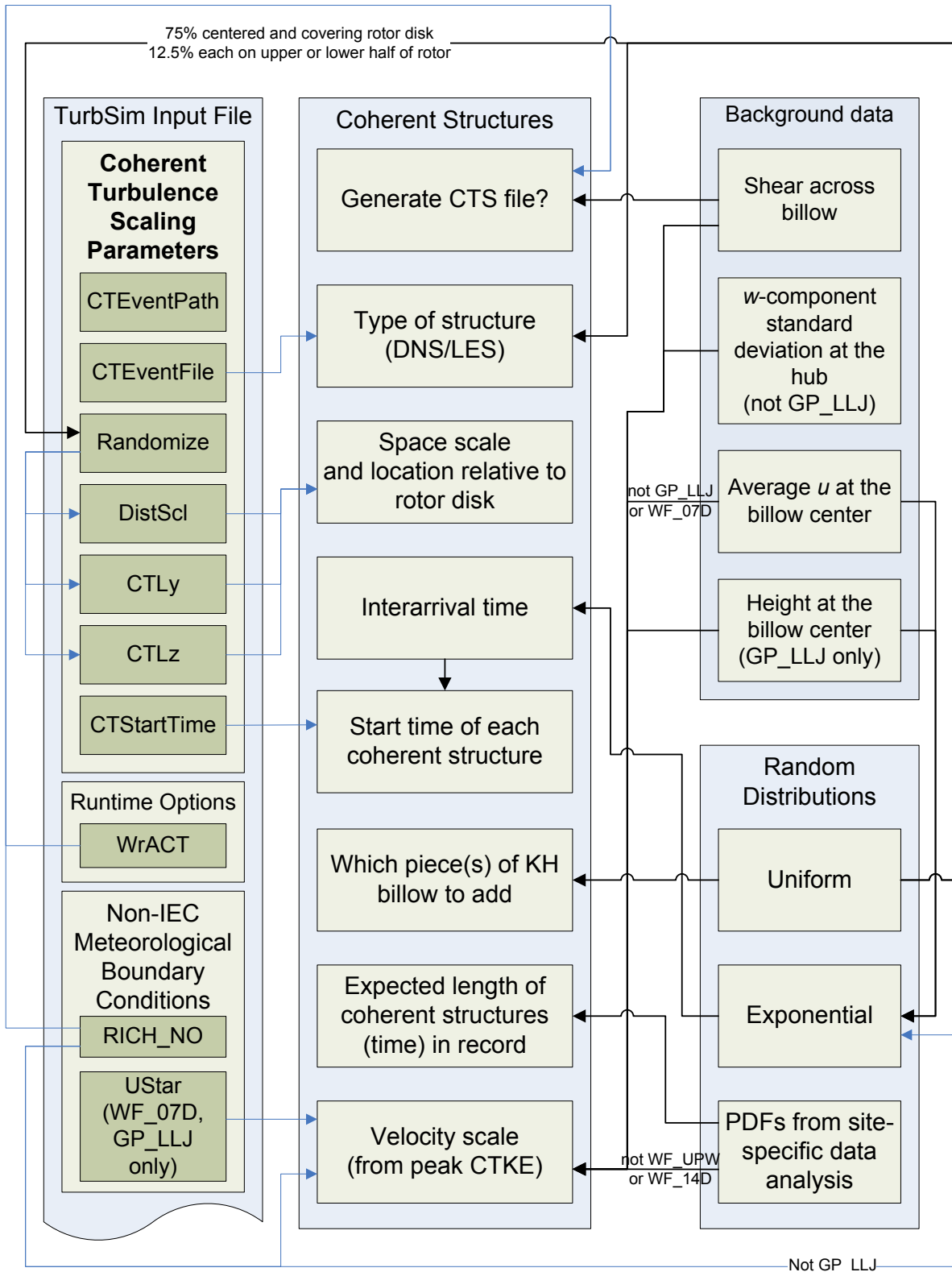


Figure C-7. Default input values for the for the Meteorological Boundary Conditions and Non-IEC Meteorological Boundary Conditions sections of the TurbSim input file





**Figure C-8. Parameters for coherent structures and the Coherent Turbulence Scaling Parameters section of the TurbSim input file; the SMOOTH model uses the GP\_LLJ scaling**

## Appendix D: Full-Field TurbSim Binary File Format

Table D-1. Full-Field TurbSim Binary File Header Format

Type (Bytes)	Parameter	Description
Integer (2)	$ID$	Identifies the file as a TurbSim binary file. $ID$ should have the value 7.
Integer (4)	$NumGrid\_Z$	The number of grid points in the vertical direction.
Integer (4)	$NumGrid\_Y$	The number of grid points in the horizontal direction.
Integer (4)	$n_{tower}$	The number of tower points below the grid.
Integer (4)	$n_t$	The number of time steps.
Real (4)	$dz$	The distance in meters between two adjacent points in the vertical direction.
Real (4)	$dy$	The distance in meters between two adjacent points in the horizontal direction.
Real (4)	$TimeStep$	The time in seconds between consecutive grids.
Real (4)	$u_{hub}$	The mean wind speed in m/s at hub height.
Real (4)	$HubHt$	The height in meters of the hub.
Real (4)	$Z_{bottom}$	The height in meters of the bottom of the grid.
<i>for i = 1, 2, 3</i>		
Real (4)	$V_{slope}(i)$	The slope used to scale the $i^{th}$ velocity component <sup>3</sup> from 4-byte reals into 2-byte integers.
Real (4)	$V_{intercept}(i)$	The intercept used to scale the $i^{th}$ velocity component <sup>3</sup> from 4-byte reals into 2-byte integers.
<i>end i</i>		
Integer (4)	$n_{characters}$	The number of characters in the ASCII string that gives the TurbSim version number, date, and time the file was generated. This number is no larger than 200.
<i>for i = 1, 2, ... n_characters</i>		
Integer (1)	$Character_i$	The ASCII integer representation of the $i^{th}$ character of the string that gives the TurbSim version number, date, and time the file was generated. $ACHAR(Character_i)$ gives the character.
<i>end i</i>		

<sup>3</sup> The three wind components are defined as  $U = 1$ ,  $V = 2$ , and  $W = 3$ .

**Table D-2. FF TurbSim Binary File Grid Format**

Type (Bytes)	Parameter	Description
<pre> for it = 1, 2, ... n<sub>t</sub>   for iz = 1, 2, ... NumGrid_Z     for iy = 1, 2, ... NumGrid_Y       for i = 1, 2, 3 </pre>	Integer (2)	$V_{grid\_norm}(i, iy, iz, it)$
<pre>       end i     end iy   end iz </pre>		The normalized $i^{th}$ velocity component <sup>4</sup> of the wind speed at time step, $it$ , and grid location ( $y(iy)$ , $z(iz)$ ).
<pre> for iz = 1, 2, ... n<sub>tower</sub>   for i = 1, 2, 3 </pre>	Integer (2)	$V_{tower\_norm}(i, iz, it)$
<pre>   end i end iz end it </pre>		The normalized $i^{th}$ -component <sup>4</sup> of the wind speed at time step, $it$ , and tower height, $Z_{tower}(iz)$ .

To convert the normalized wind in the FF TurbSim binary file to velocities in units of meters per second, use the following equations:

$$V_{grid}(i, iy, iz, it) = \frac{V_{grid\_norm}(i, iy, iz, it) - V_{intercept}(i)}{V_{slope}(i)} \quad (D-1)$$

$$V_{tower}(i, iz, it) = \frac{V_{tower\_norm}(i, iz, it) - V_{intercept}(i)}{V_{slope}(i)} \quad (D-2)$$

The corresponding lateral locations,  $Y$ , and vertical locations,  $Z$ , of the grid and/or tower points are given in units of meters by

$$\begin{aligned} Y_{grid}(iy) &= -0.5(NumGrid\_Y - 1)dy + (iy - 1)dy \\ Z_{grid}(iz) &= Z_{bottom} + (iz - 1)dz \end{aligned} \quad (D-3)$$

and

$$\begin{aligned} Y_{tower} &= 0 \\ Z_{tower}(iz) &= Z_{bottom} - (iz - 1)dz \end{aligned} \quad (D-4)$$

<sup>4</sup> The three wind components are defined as  $U = 1$ ,  $V = 2$ , and  $W = 3$ .

## Appendix E: Full-Field Bladed-Style Binary File Format

Table E-1. Full-Field Bladed-Style Binary File Header Format

Type (Bytes)	Parameter	Description
Integer (2)	<i>ID</i>	Identifies the file as a Bladed-style binary file. <i>ID</i> should have the value -99.
Integer (2)	<i>ID2</i>	<i>ID2</i> should have the value 4 to include the next 7 parameters.
Integer (4)	<i>nc</i>	The number of wind components. <i>nc</i> should be 3.
Real (4)	<i>Latitude</i>	This value is not used in AeroDyn.
Real (4)	<i>Z0</i>	The surface roughness. This value is not used in AeroDyn.
Real (4)	<i>Ztmp</i>	The height at the center of the grid, in meters.
Real (4)	$100 * TI(u)$	The turbulence intensity of the <i>u</i> component, in percent.
Real (4)	$100 * TI(v)$	The turbulence intensity of the <i>v</i> component, in percent.
Real (4)	$100 * TI(w)$	The turbulence intensity of the <i>w</i> component, in percent.
Real (4)	<i>dz</i>	The grid spacing in the vertical direction, in meters.
Real (4)	<i>dy</i>	The grid spacing in the lateral direction, in meters.
Real (4)	$u_{hub} * TimeStep$	The longitudinal grid resolution, in meters.
Integer (4)	<i>nt / 2</i>	Half the number of points in the longitudinal direction.
Real (4)	$u_{hub}$	The mean wind speed (in meters per second) at hub height.
Real (4)	<i>Unused</i>	The value 0. This parameter is not used in AeroDyn.
Real (4)	<i>Unused</i>	The value 0. This parameter is not used in AeroDyn.
Real (4)	<i>Unused</i>	The value 0. This parameter is not used in AeroDyn.
Integer (4)	<i>Unused</i>	The value 0. This parameter is not used in AeroDyn.
Integer (4)	<i>RandSeed1</i>	This value is not used in AeroDyn.
Integer (4)	<i>NumGrid_Z</i>	The number of grid points vertically.
Integer (4)	<i>NumGrid_Y</i>	The number of grid points laterally.
Integer (4)	<i>Unused</i>	The value 0. This parameter is not used in AeroDyn.
Integer (4)	<i>Unused</i>	The value 0. This parameter is not used in AeroDyn.
Integer (4)	<i>Unused</i>	The value 0. This parameter is not used in AeroDyn.
Integer (4)	<i>Unused</i>	The value 0. This parameter is not used in AeroDyn.
Integer (4)	<i>Unused</i>	The value 0. This parameter is not used in AeroDyn.
Integer (4)	<i>Unused</i>	The value 0. This parameter is not used in AeroDyn.

**Table E-2. Format of Grid Velocities in Full-Field Bladed-Style Binary File Format**

Type (Bytes)	Parameter	Description
<i>for it = 1, 2, ... nt</i>		
<i>for iz = 1, 2, ... NumGrid_Z</i>		
<i>for iy = 1, 2, ... NumGrid_Y</i>		
Integer (2)	$U_{grid\_norm}(iy, iz, it)$	The normalized $U$ component of the wind speed at time step, $it$ , and grid location ( $y(iy)$ , $z(iz)$ ).
Integer (2)	$V_{grid\_norm}(iy, iz, it)$	The normalized $V$ component of the wind speed at time step, $it$ , and grid location ( $y(iy)$ , $z(iz)$ ).
Integer (2)	$W_{grid\_norm}(iy, iz, it)$	The normalized $W$ component of the wind speed at time step, $it$ , and grid location ( $y(iy)$ , $z(iz)$ ).
<i>end iy</i>		
<i>end iz</i>		
<i>end it</i>		

To convert the normalized wind in the FF Bladed-style binary file to velocities in units of meters per second, use the following equations:

$$U_{grid}(iy, iz, it) = u_{hub} \left( \frac{TI(u)}{1000} U_{grid\_norm}(iy, iz, it) + 1 \right), \quad (E-1)$$

$$V_{grid}(iy, iz, it) = u_{hub} \left( \frac{TI(v)}{1000} V_{grid\_norm}(iy, iz, it) \right), \quad (E-2)$$

and

$$W_{grid}(iy, iz, it) = u_{hub} \left( \frac{TI(w)}{1000} W_{grid\_norm}(iy, iz, it) \right). \quad (E-3)$$

Here  $TI$  represents the turbulence intensity as a decimal, not a percentage.

The corresponding vertical locations,  $Z$ , of the grid points are given in units of meters by

$$Z_{grid}(iz) = -0.5(NumGrid\_Z - 1)dz + HubHt - HeightOffset + (iz - 1)dz \quad (E-4)$$

using values of  $HubHt$  and  $HeightOffset$  from the summary file. The lateral locations,  $Y$ , of the grid points depend on the input value  $Clockwise$  (read from the summary file) and are given by

$$Y_{grid}(iy) = \begin{cases} -0.5(NumGrid\_Y - 1)dy + (iy - 1)dy, & Clockwise = FALSE \\ 0.5(NumGrid\_Y - 1)dy - (iy - 1)dy, & Clockwise = TRUE \end{cases}. \quad (E-5)$$

## Appendix F: Tower Data Binary File Format

TurbSim tower files have a “.twr” extension. Each file contains a header of 4-byte real and integer values, followed by 2-byte integer time series of the three wind components at each point on the tower grid. The wind components at the tower points are normalized and stored in 2-byte binary integers, exactly the same way that Bladed-style full-field wind files are written. The tower files have the same vertical resolution as the full-field grid, with points going downward from the bottom of the full grid in a single line at the tower centerline.

**Table F-1: Format of Header in TurbSim Binary Tower-Data File**

Type (Bytes)	Parameter	Description
Real (4)	$dz$	Vertical grid resolution, in meters.
Real (4)	$u_{hub} * TimeStep$	Longitudinal grid resolution, in meters.
Real (4)	$Zmax$	The height of the highest tower point, in meters.
Real (4)	$nt$	The number of points in the longitudinal direction.
Real (4)	$nz$	The number of vertical tower points.
Real (4)	$u_{hub}$	The mean wind speed, in meters per second.
Real (4)	$100 * TI(u)$	The turbulence intensity of the $u$ component, in percent.
Real (4)	$100 * TI(v)$	The turbulence intensity of the $v$ component, in percent.
Real (4)	$100 * TI(w)$	The turbulence intensity of the $w$ component, in percent.

**Table F-2: Format of Grid Velocities in TurbSim Binary Tower-Data File**

Type (Bytes)	Parameter	Description
For each increasing time step ( $nt$ points), and starting at the top of the grid, going downward ( $nz$ points) the data are stored as:		
<i>for it = 1, 2, ... nt</i>		
<i>  for iz = 1, 2, ... nz</i>		
Integer (2)	$U_{tower\_norm}(iz, it)$	Normalized $U$ component of the wind speed at time step, $it$ , and height $z(iz)$ .
Integer (2)	$V_{tower\_norm}(iz, it)$	Normalized $V$ component of the wind speed at time step, $it$ , and height $z(iz)$ .
Integer (2)	$W_{tower\_norm}(iz, it)$	Normalized $W$ component of the wind speed at time step, $it$ , and height $z(iz)$ .
<i>  end iz</i>		
<i>end it</i>		

To convert the normalized wind in the tower data binary file to velocities in units of meters per second, use the following equations:

$$U_{tower}(iz, it) = u_{hub} \left( \frac{TI(u)}{1000} U_{tower\_norm}(iz, it) + 1 \right), \quad (F-1)$$

$$V_{tower}(iz, it) = u_{hub} \left( \frac{TI(v)}{1000} V_{tower\_norm}(iz, it) \right), \quad (F-2)$$

and

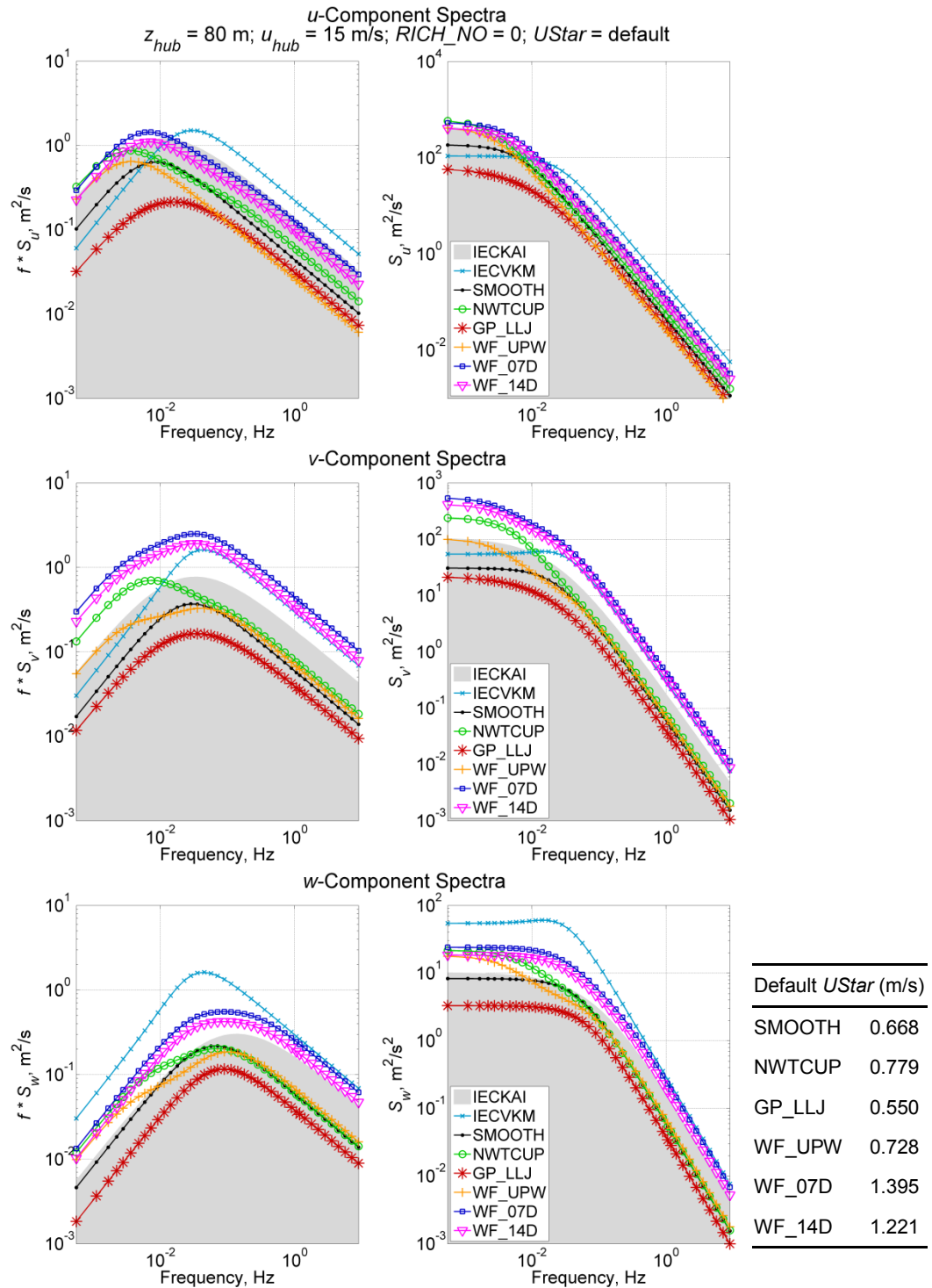
$$W_{tower}(iz, it) = u_{hub} \left( \frac{TI(w)}{1000} W_{tower\_norm}(iz, it) \right). \quad (F-3)$$

Here  $TI$  represents the turbulence intensity as a decimal, not a percentage.

The corresponding lateral locations,  $Y$ , and vertical locations,  $Z$ , of the tower points are given in units of meters using values of  $Z_{max}$  from the file header:

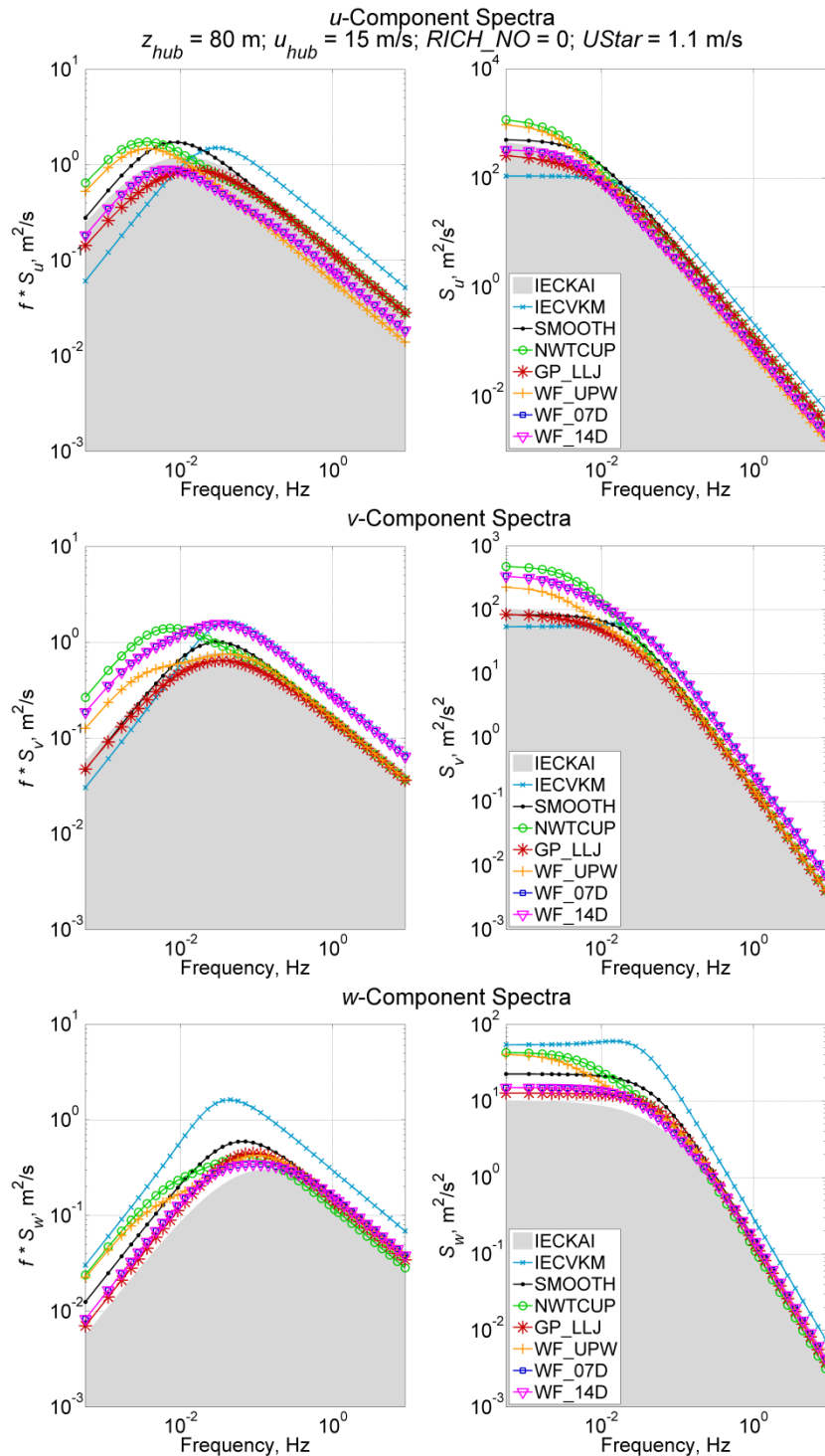
$$\begin{aligned} Y_{tower} &= 0 \\ Z_{tower}(iz) &= Z_{max} - (iz - 1) dz \end{aligned} \quad (F-4)$$

## Appendix G: Velocity Spectra Comparison Plots

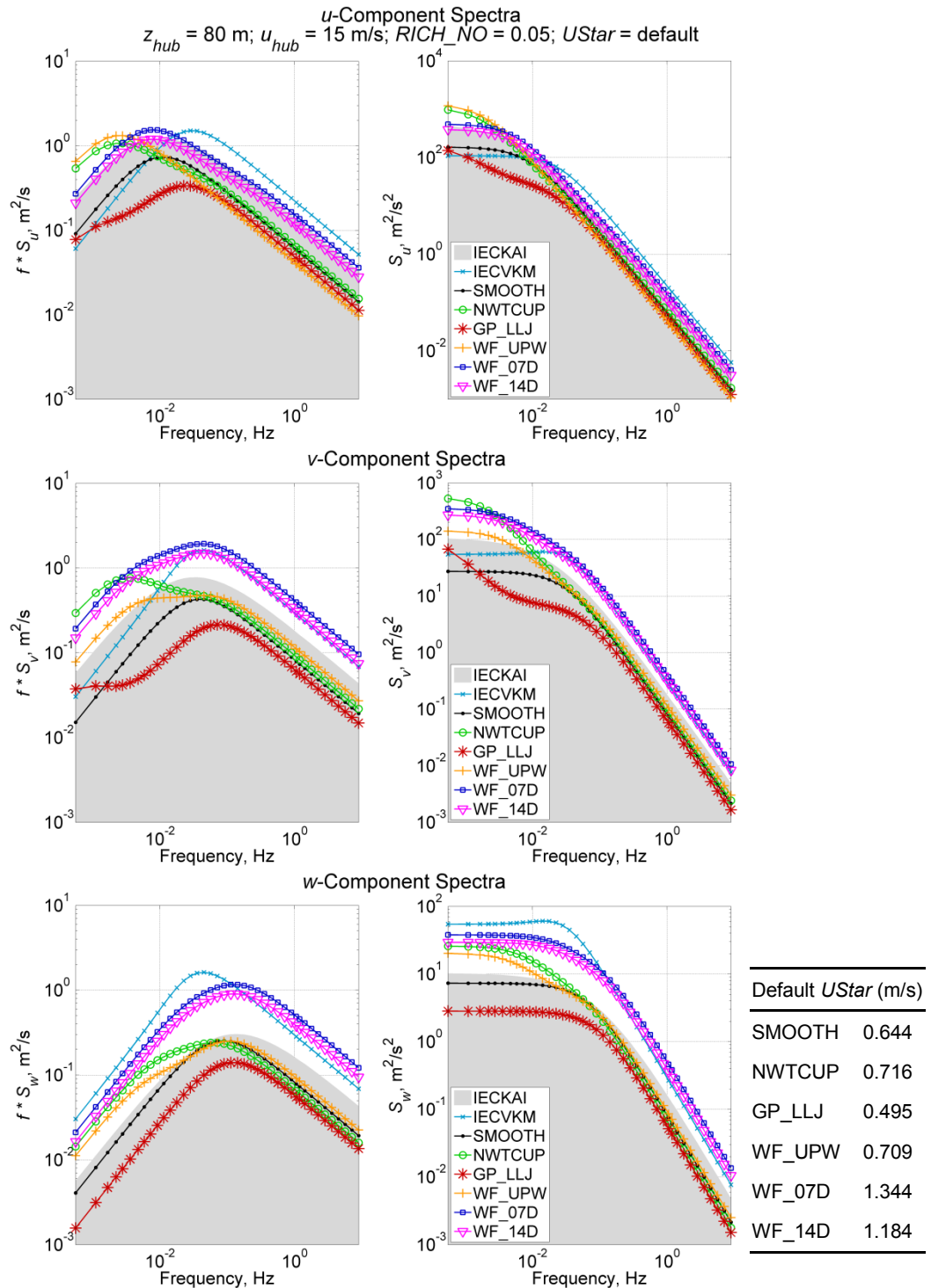


**Figure G-1. Neutral velocity spectra for the 8 spectral models available in TurbSim, using a 15 m/s wind speed at 80 m; IECKAI and IECVKM use NTM category “B” and 61400-1 3<sup>rd</sup> ed. scaling; the non-IEC models use *RICH\_NO* = 0 and *UStar* = “default”**

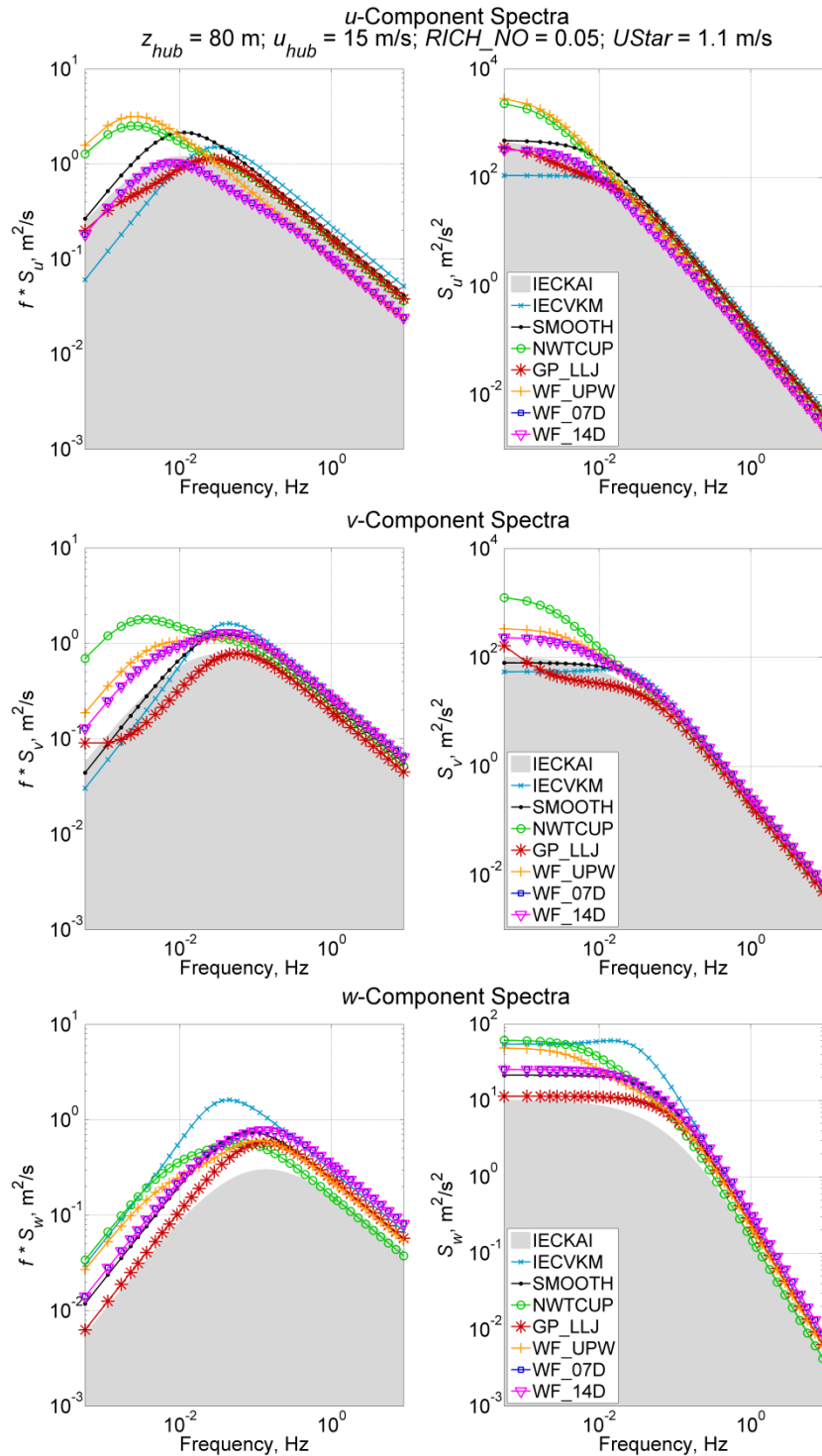




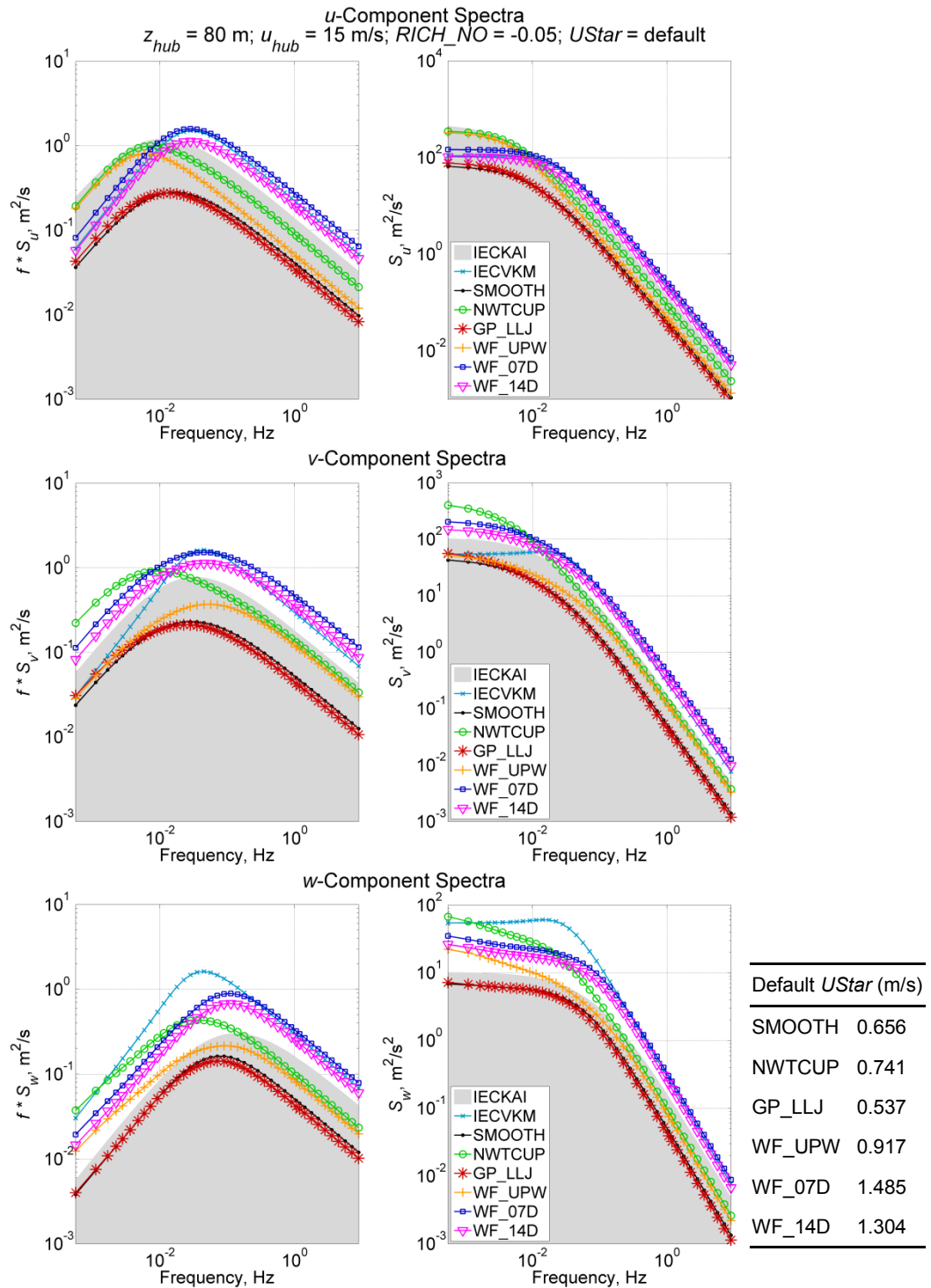
**Figure G-2. Neutral velocity spectra for the 8 spectral models available in TurbSim, using a 15 m/s wind speed at 80 m; IECKAI and IECVKM use NTM category “B” and 61400-1 3<sup>rd</sup> ed. scaling; the non-IEC models use *RICH\_NO* = 0 and *UStar* = 1.1 m/s**



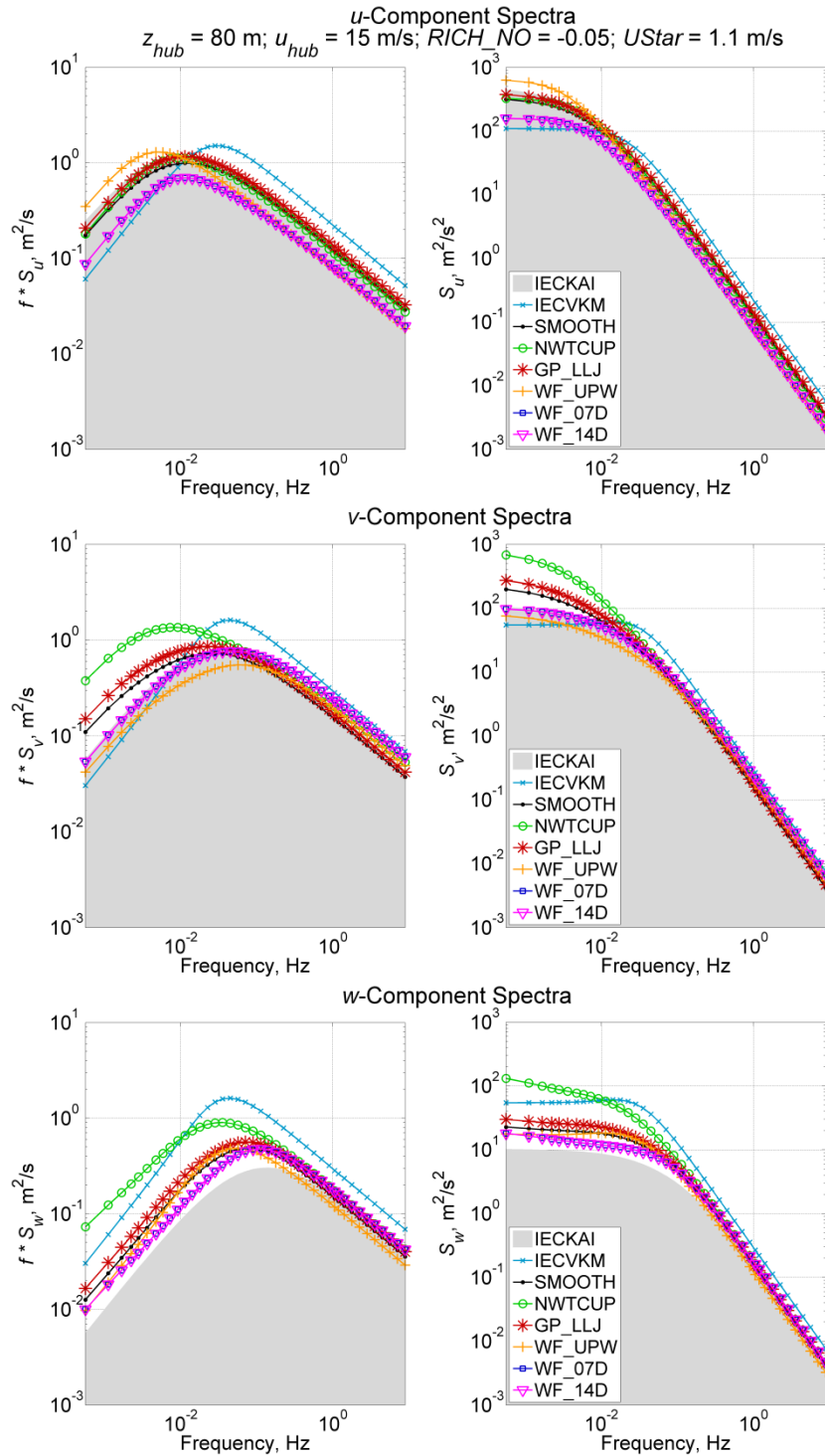
**Figure G-3. Stable velocity spectra using a 15 m/s wind speed at 80 m; the non-IEC models use  $RICH\_NO = 0.05$  and  $UStar = \text{“default”}$ ; The IEC models, which are neutral ( $RICH\_NO = 0$ ), were added for reference; they use NTM category “B” and 61400-1 3<sup>rd</sup> ed. scaling**



**Figure G-4. Stable velocity spectra using a 15 m/s wind speed at 80 m; the non-IEC models use RICH\_NO = 0.05 and UStar = 1.1 m/s; the IEC models, which are neutral (RICH\_NO = 0), were added for reference; they use NTM category "B" and 61400-1 3<sup>rd</sup> ed. scaling**



**Figure G-5. Unstable velocity spectra using a 15 m/s wind speed at 80 m; the non-IEC models use  $RICH\_NO = -0.05$  and  $UStar = \text{“default”}$ ; the IEC models, which are neutral ( $RICH\_NO = 0$ ), were added for reference; they use NTM category “B” and 61400-1 3<sup>rd</sup> ed. scaling**



**Figure G-6. Unstable velocity spectra using a 15 m/s wind speed at 80 m; the non-IEC models use  $RICH\_NO = -0.05$  and  $UStar = 1.1 \text{ m/s}$ ; the IEC models, which are neutral ( $RICH\_NO = 0$ ), were added for reference; they use NTM category “B” and 61400-1 3<sup>rd</sup> ed. scaling**

## Appendix H: Sample AeroDyn Coherent Turbulence Parameter Input File

```
Example Coherent Turbulence Parameter input file (TurbSim_AD.ctp). Valid with AeroDyn 12.57.
# Parameters that can vary from one turbine simulation to the next:
"H:\x90_i16" | CT_Spath - Path to coherent turbulence data files
"TurbSim.cts" | CT_Sfile - File containing time steps of the coherent turbulence event files
"TurbSim.wnd" | CT_Backgr - Name of file containing background wind data (quoted string)
  1           | CT_DF_Y - Decimation factor for wind data in the y direction
  1           | CT_DF_Z - Decimation factor for wind data in the z direction
```

```
=====
NOTE: Do not add or remove any lines in this file!
=====
```

For decimation factors, 1 = use every point, 2 = use every other point, etc.

Figure H-1. Sample AeroDyn coherent turbulence parameter input file

# REPORT DOCUMENTATION PAGE

*Form Approved*  
OMB No. 0704-0188

The public reporting burden for this collection of information is estimated to average 1 hour per response, including the time for reviewing instructions, searching existing data sources, gathering and maintaining the data needed, and completing and reviewing the collection of information. Send comments regarding this burden estimate or any other aspect of this collection of information, including suggestions for reducing the burden, to Department of Defense, Executive Services and Communications Directorate (0704-0188). Respondents should be aware that notwithstanding any other provision of law, no person shall be subject to any penalty for failing to comply with a collection of information if it does not display a currently valid OMB control number.

**PLEASE DO NOT RETURN YOUR FORM TO THE ABOVE ORGANIZATION.**

<b>1. REPORT DATE (DD-MM-YYYY)</b> September 2012		<b>2. REPORT TYPE</b> Technical report		<b>3. DATES COVERED (From - To)</b>		
<b>4. TITLE AND SUBTITLE</b> TurbSim User's Guide: Version 1.06.00				<b>5a. CONTRACT NUMBER</b> DE-AC36-08-GO28308		
				<b>5b. GRANT NUMBER</b>		
				<b>5c. PROGRAM ELEMENT NUMBER</b>		
<b>6. AUTHOR(S)</b> B.J. Jonkman, L. Kilcher				<b>5d. PROJECT NUMBER</b> NREL/TP-xxx-xxxx		
				<b>5e. TASK NUMBER</b> WER8.2102		
				<b>5f. WORK UNIT NUMBER</b>		
<b>7. PERFORMING ORGANIZATION NAME(S) AND ADDRESS(ES)</b> National Renewable Energy Laboratory 1617 Cole Blvd. Golden, CO 80401-3393				<b>8. PERFORMING ORGANIZATION REPORT NUMBER</b> NREL/TP-xxx-xxxx		
<b>9. SPONSORING/MONITORING AGENCY NAME(S) AND ADDRESS(ES)</b>				<b>10. SPONSOR/MONITOR'S ACRONYM(S)</b> NREL		
				<b>11. SPONSORING/MONITORING AGENCY REPORT NUMBER</b>		
<b>12. DISTRIBUTION AVAILABILITY STATEMENT</b> National Technical Information Service U.S. Department of Commerce 5285 Port Royal Road Springfield, VA 22161						
<b>13. SUPPLEMENTARY NOTES</b>						
<b>14. ABSTRACT (Maximum 200 Words)</b> The TurbSim stochastic inflow turbulence code was developed to provide a numerical simulation of a full-field flow that contains coherent turbulence structures that reflect the proper spatiotemporal turbulent velocity field relationships seen in instabilities associated with nocturnal boundary layer flows. This report provides a user's guide for the TurbSim code.						
<b>15. SUBJECT TERMS</b> wind turbine design code simulations; inflow turbulence code; TurbSim						
<b>16. SECURITY CLASSIFICATION OF:</b>			<b>17. LIMITATION OF ABSTRACT</b>	<b>18. NUMBER OF PAGES</b>	<b>19a. NAME OF RESPONSIBLE PERSON</b>	
. REPORT Unclassified	b. ABSTRACT Unclassified	c. THIS PAGE Unclassified			<b>19b. TELEPHONE NUMBER (Include area code)</b>	
			UL			

Standard Form 298 (Rev. 8/98)  
Prescribed by ANSI Std. Z39.18