



# Control System Stability for Converter-Dominated Grids

Shahil Shah, Vahan Gevorgian, Przemyslaw Koralewicz, and Robb Wallen

ESIG Spring Technical Workshop (April 28, 2020)

# Outline

- Stability problems in converter-dominated grids
- Impedance-based stability analysis
- A case study:
  - Reactive power oscillations in wind power plants.
- Effect of grid-forming resources on stability:
  - Grid-forming Type III wind turbines
  - Damping of inter-area modes.

# New Stability Problems: Control Interactions

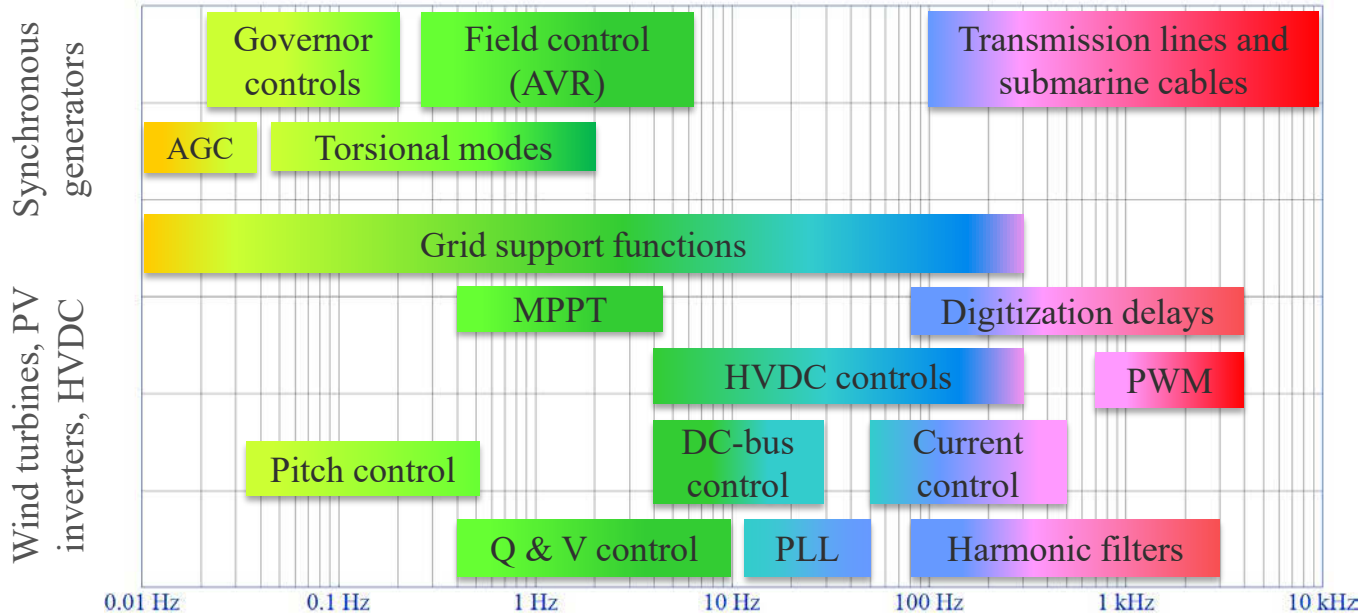

## Resonating variables:

- **Phasor (DC) variables:** *Frequency, voltage magnitude, active and reactive power flow*
- **Phase (AC) variables:** *Phase voltages and currents*

- Major challenges: (1) fast controls, (2) diversity of controls, (3) unavailability of dynamic models, (4) complex dynamics

*SSO in phasor variables is not the same as SSO in phase variables.*

# Impedance-Based Stability Analysis

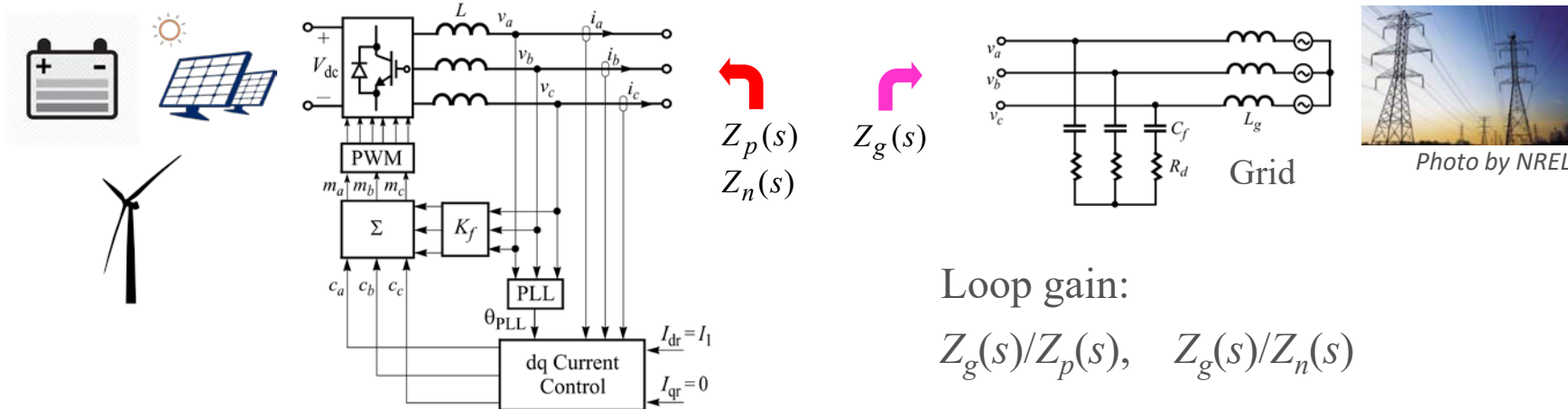

- Impedance responses of two subsystems are compared:
  - Magnitude response intersection points give frequencies of resonance modes.
  - Phase difference at intersection points gives damping.

# Positive-Sequence Impedance of a 4-MW Turbine



Photo by NREL

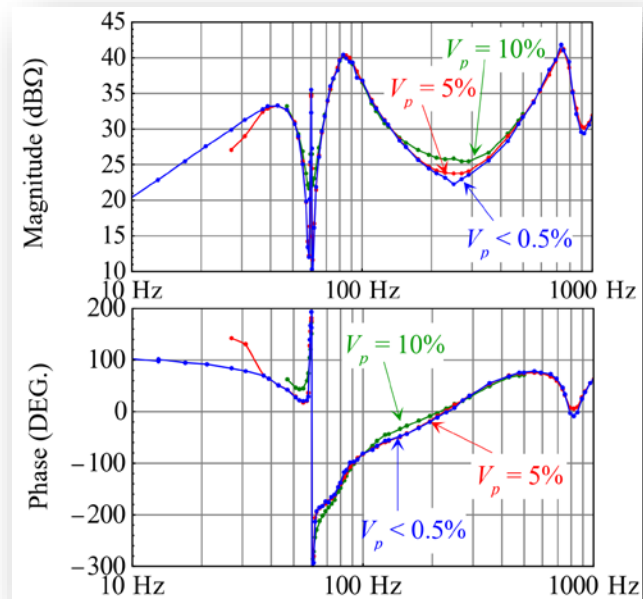

- Automated sequence impedance measurement by a 7-MW grid simulator for different operation conditions

# Adoption by Industry

## Root-cause finding; grid codes; control design

- TenneT (Germany)
  - Wind power plant owner needs to ensure stability and avoid resonance problems.
- ERCOT (United States)
  - Requires new wind projects to conduct SSR studies—impedance scans.
- State Grid (China)
  - CHIL simulation lab of CEPRI
  - Analysis of resonance for new wind power plants
  - Maintain library of impedance models.
- Grid integration studies by utilities.

## • Model validation

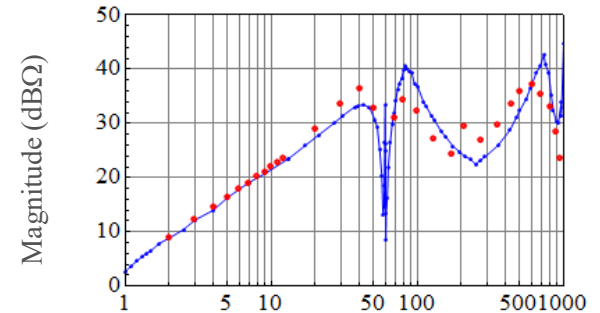

Blue: Measurements of 4-MW DFIG  
Red: PSCAD model from OEM

# Reactive Power Oscillations Between Wind Turbines

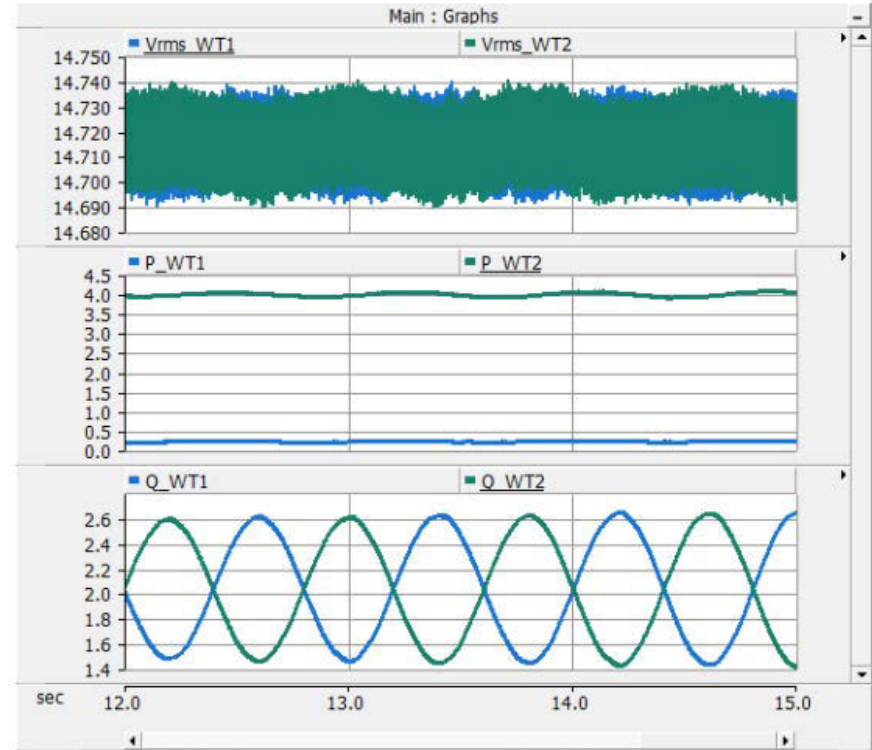
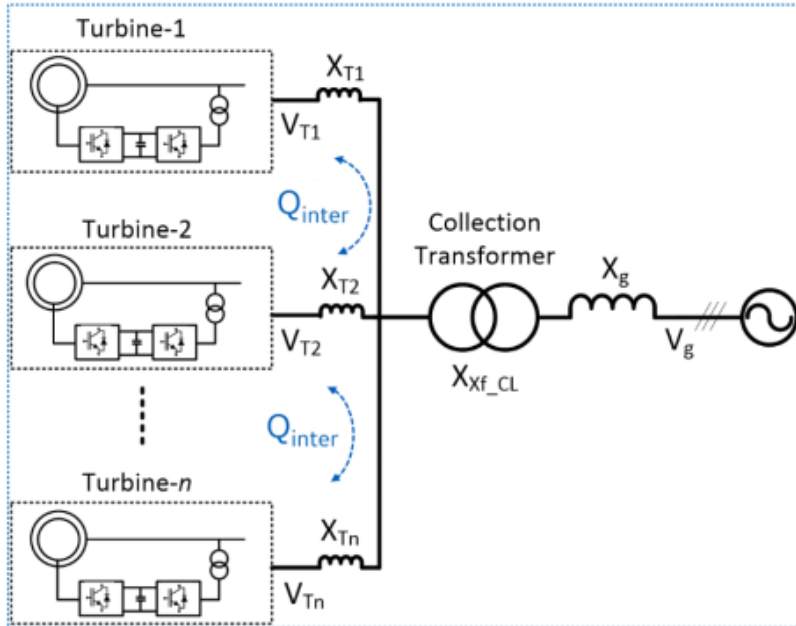

# Reactive Power Oscillations in Wind

- 4-MW wind turbine at NREL:
  - Turbine reactive power output had 1.2-Hz oscillations following a small (1%) step change in voltage.

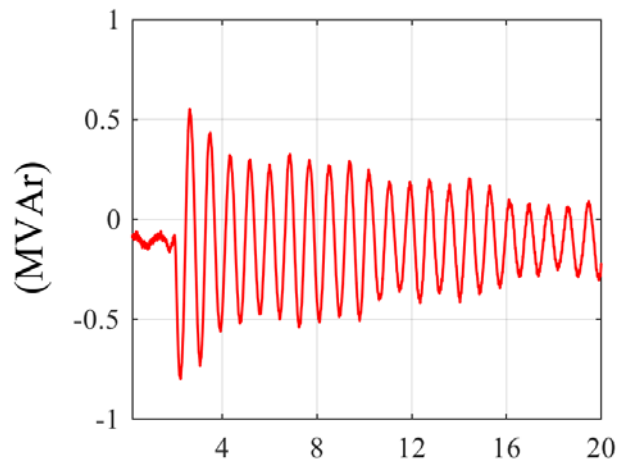

- Hornsea wind power plant in the United Kingdom:
  - Hornsea experienced reactive power oscillations before the major blackout event in the United Kingdom grid in August 2019.
  - The wind power plant reactive power output had 8.5-Hz oscillations following a small (2%) step change in voltage.



# Power Domain Impedance Theory

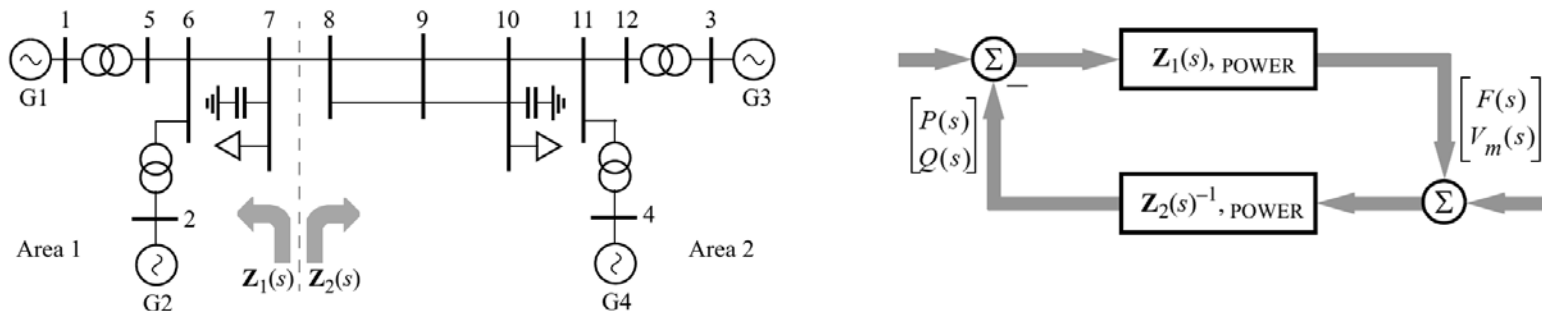

- Definition of power domain impedance:

$$\begin{bmatrix} F(s) \\ V_m(s) \end{bmatrix} = \begin{bmatrix} Z_{FP}(s) & Z_{FQ}(s) \\ Z_{VP}(s) & Z_{VQ}(s) \end{bmatrix} \begin{bmatrix} P(s) \\ Q(s) \end{bmatrix} \quad \begin{bmatrix} P(s) \\ Q(s) \end{bmatrix} = \begin{bmatrix} Y_{PF}(s) & Y_{PV}(s) \\ Y_{QF}(s) & Y_{QV}(s) \end{bmatrix} \begin{bmatrix} F(s) \\ V_m(s) \end{bmatrix}$$

# Power Domain Admittance of 4-MW Turbine

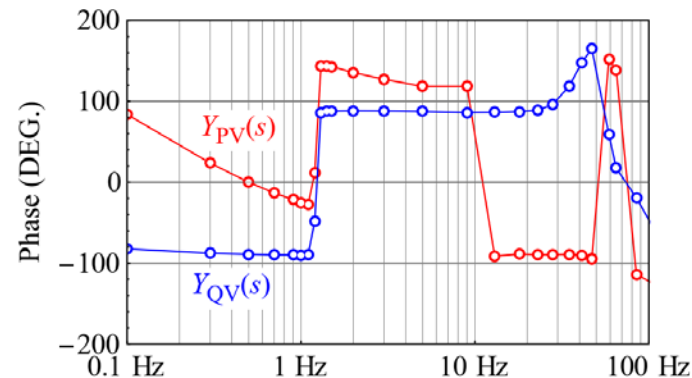
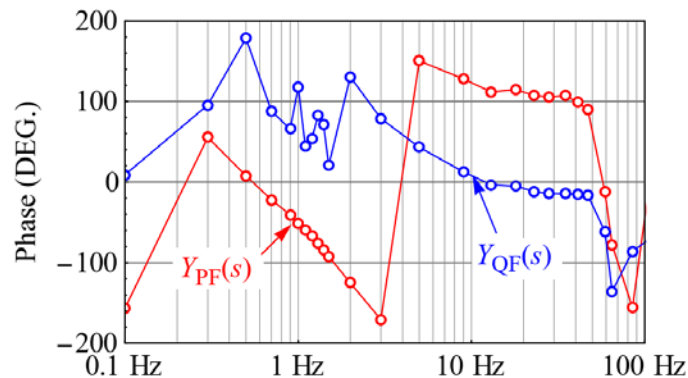
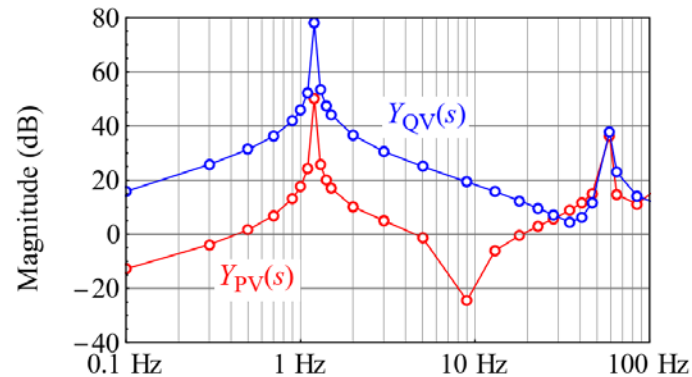
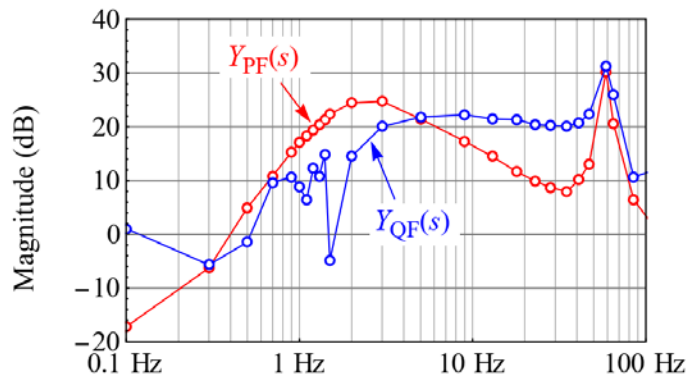

# Analysis of Reactive Power Dynamics

- Equivalent circuit:
  - Reactive power flow is interpreted as instantaneous current.
  - Voltage magnitude is interpreted as instantaneous voltage.

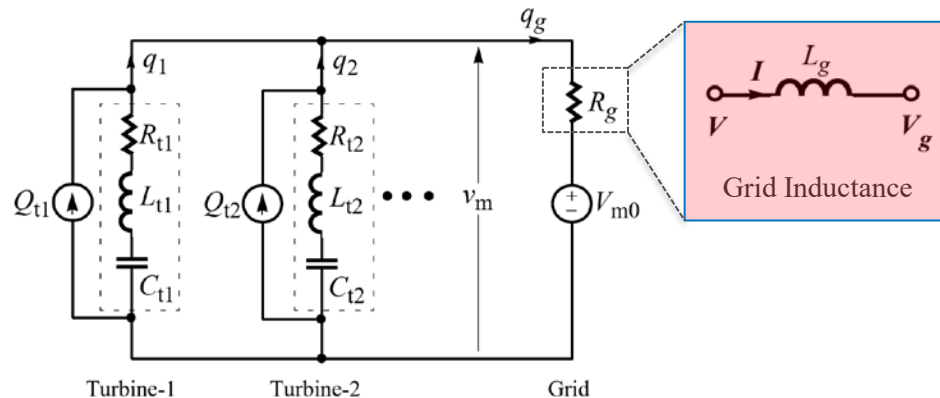

- Analysis results:
  - Inductive grid impedance acts as resistor.
  - Weak inductive grid will damp plant-to-grid reactive power oscillations.
  - Weak inductive grid will not damp turbine-to-turbine reactive power oscillations.

# Effect of Grid Strength on Reactive Power Oscillations

- Very strong grid ( $L_g = 0$ )

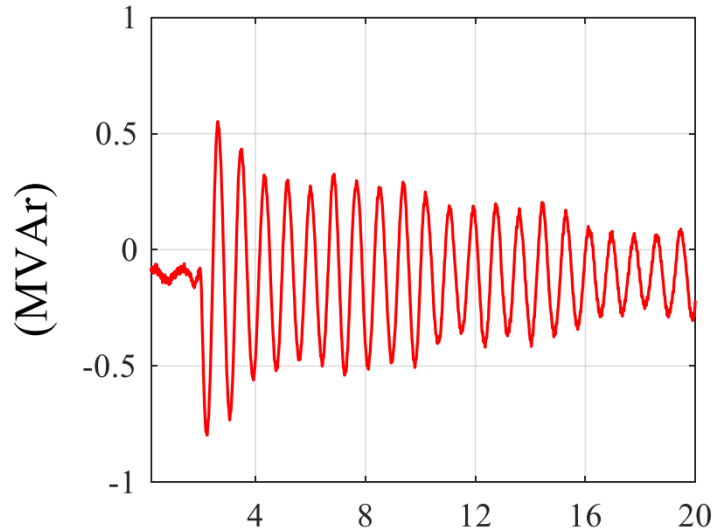

- Not-so-strong grid ( $L_g = 8$  mH)

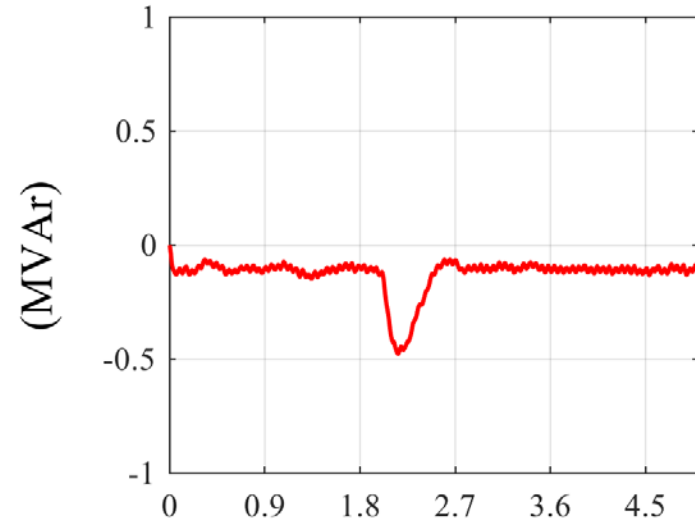

- *Weak grid damps reactive power oscillations from wind power plants.*

# Reactive Power Droop for Damping

- Transfer function from voltage magnitude to reactive power output

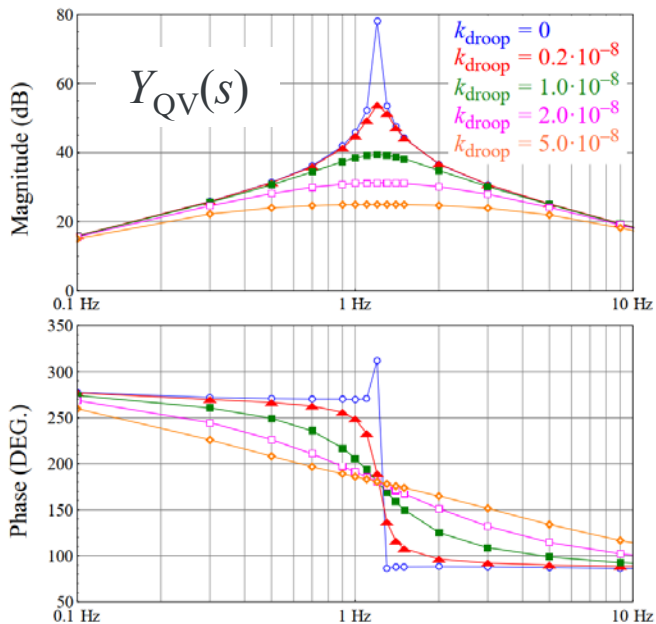

- Turbine-to-turbine oscillations

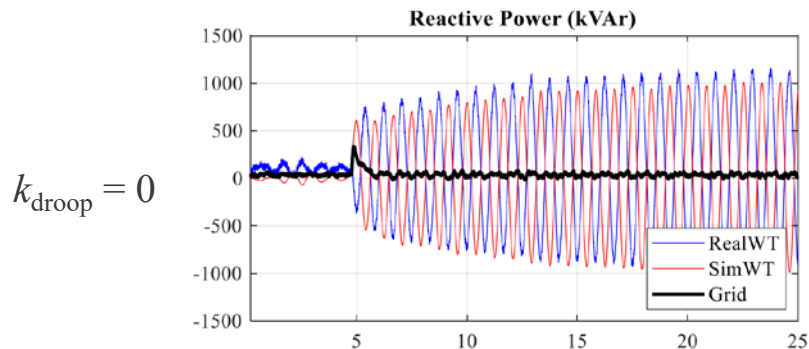

$k_{\text{droop}} = 1 \times 10^{-8}$

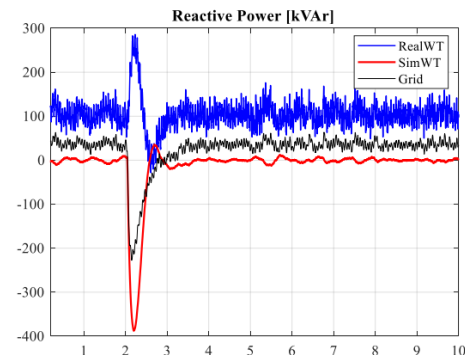

# Grid-Forming Control of Type III Wind Turbines

- Vector current control

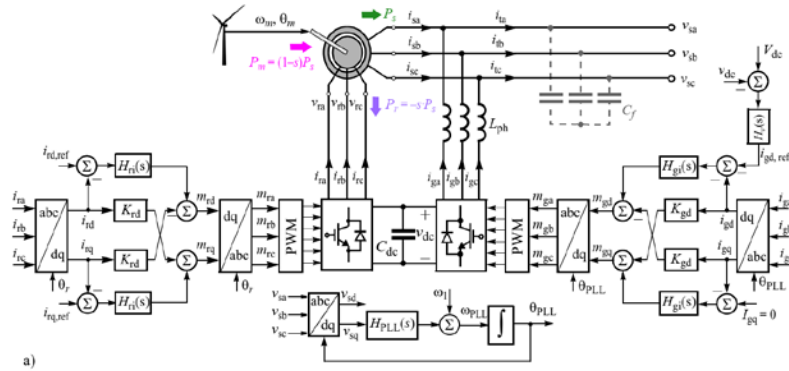

- MPPT/active power control

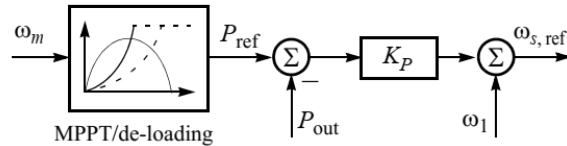

- Voltage control

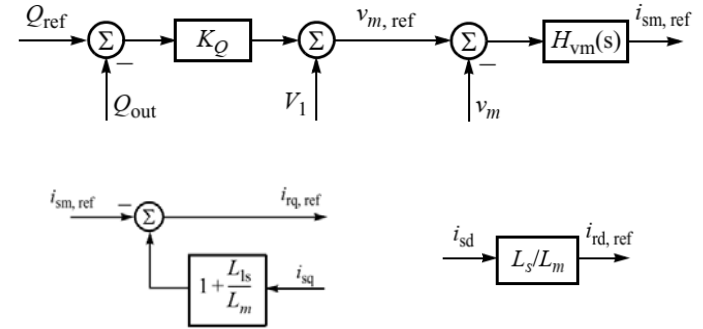

- Frequency control

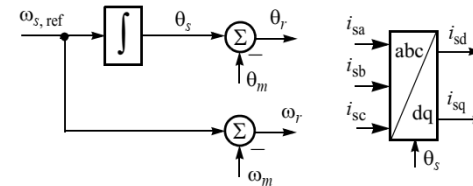

# PSCAD Model

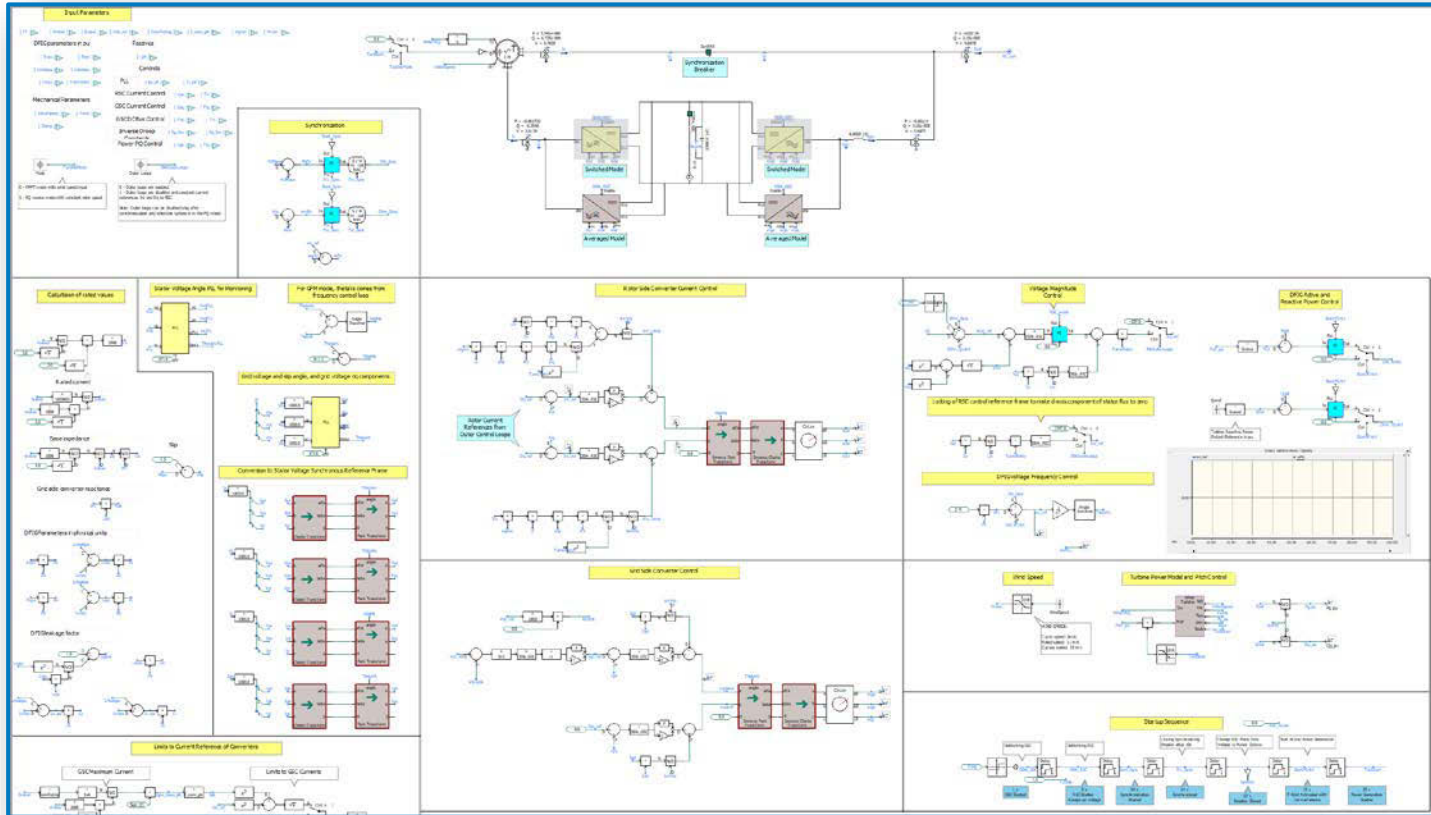

# Voltage and Frequency Control Performance

- Frequency reference increased by 5 Hz:
  - Islanded operation.
- Voltage magnitude reference increased by 10%:
  - Islanded operation.

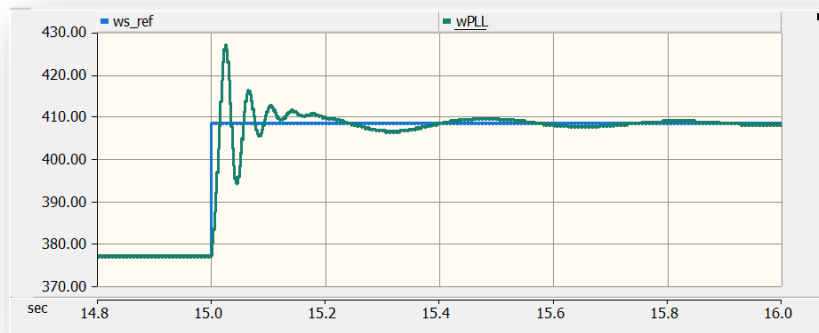



# Operation with Weak Grid

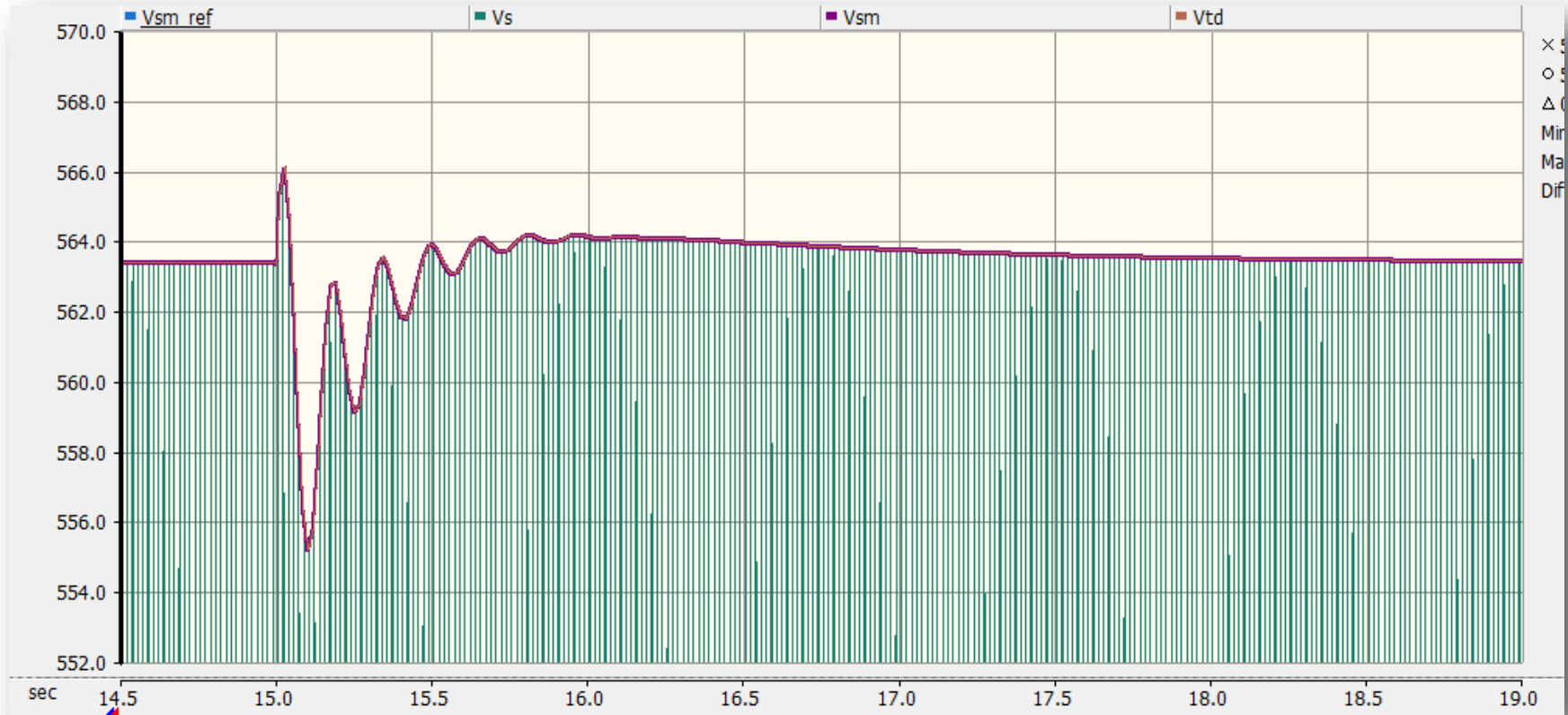

# Operation with Strong Grid

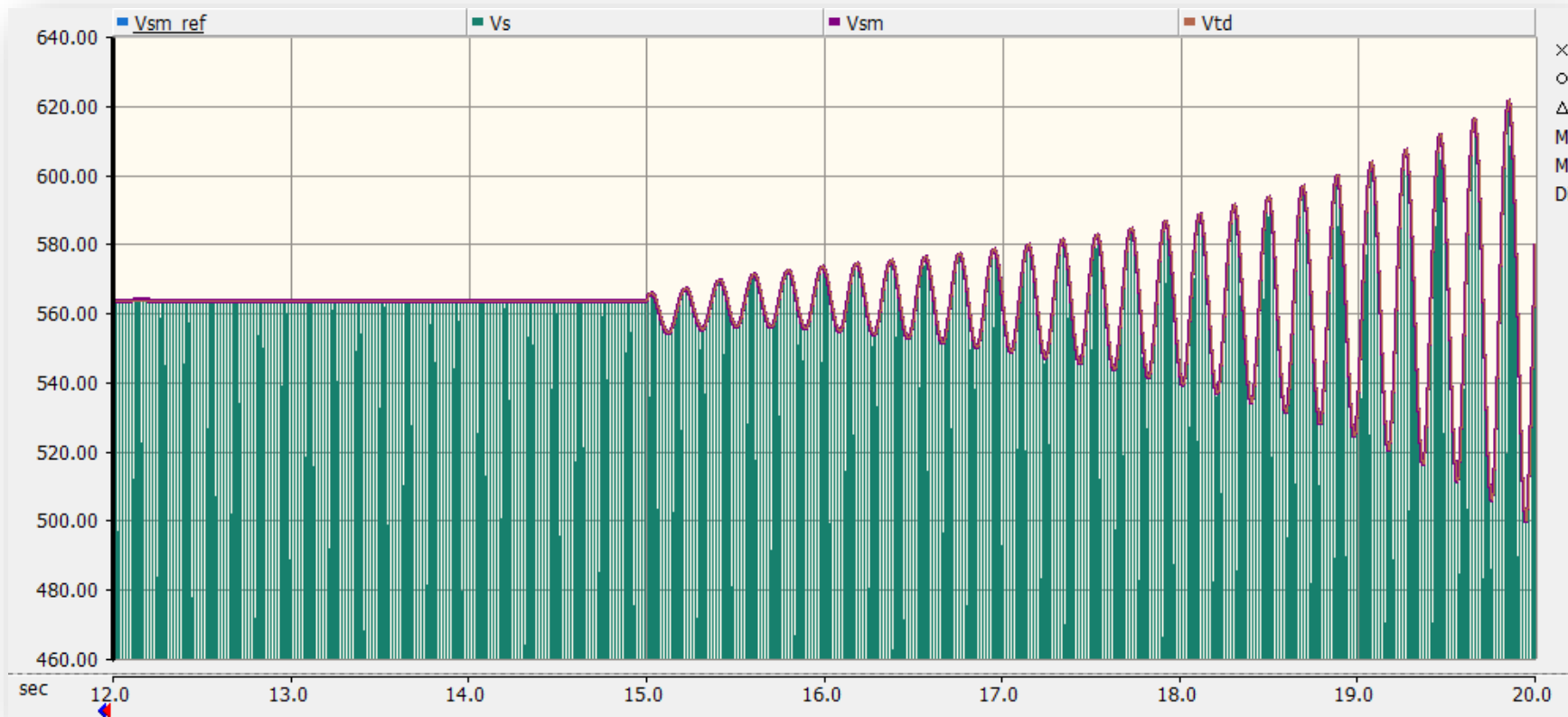

# Damping of Inter-Area Modes by GFM Inverters

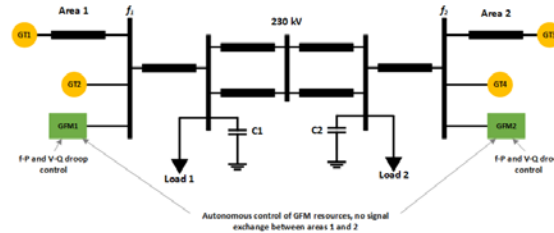

Without GFM inverters

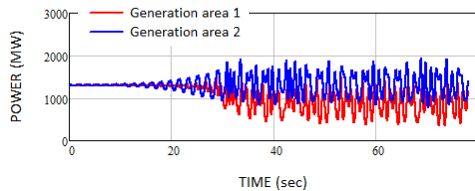
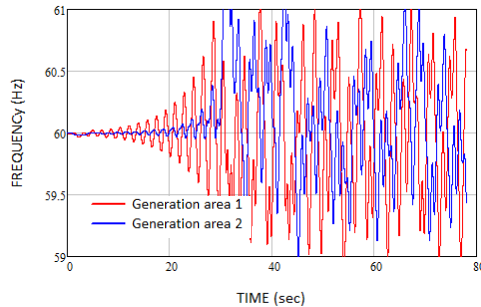

With GFM inverters

Frequency in areas 1 and 2

Droop = 2 mHz/MW

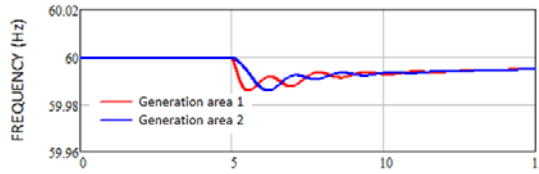

Droop = 8 mHz/MW

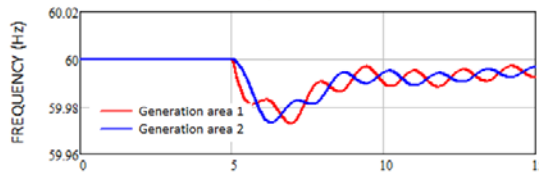

Response of GFM resources 1 and 2

Droop = 2 mHz/MW

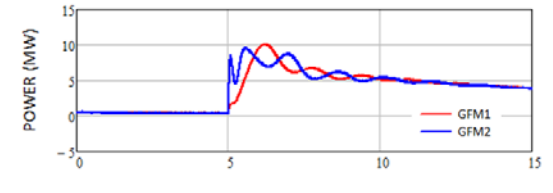

Droop = 8mHz/MW

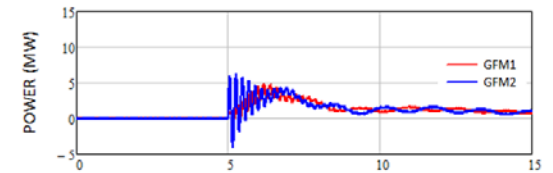

# Summary

- Impedance methods are effective for understanding stability impacts of inverter-based resources
- Vendor-supplied high-fidelity EMTP models of inverter-based resources are required for stability analysis of modern power systems.
  - Focusing on only one control function, e.g., phase-locked loop, in modeling might not be enough.
  - Weak grids are not always “bad” from the stability standpoint.
- Grid-forming resources are helpful for fundamental voltage and frequency stability.
  - But they might worsen existing or introduce new dynamic stability problems.

# Thank you!

---

**[www.nrel.gov](http://www.nrel.gov)**

Shahil.Shah@nrel.gov

NREL/PR-5D00-76862

This work was authored by Alliance for Sustainable Energy, LLC, the manager and operator of the National Renewable Energy Laboratory for the U.S. Department of Energy (DOE) under Contract No. DE-AC36-08GO28308. Funding provided by U.S. Department of Energy Office of Energy Efficiency and Renewable Energy Wind Energy Technologies Office. The views expressed in the article do not necessarily represent the views of the DOE or the U.S. Government. The U.S. Government retains and the publisher, by accepting the article for publication, acknowledges that the U.S. Government retains a nonexclusive, paid-up, irrevocable, worldwide license to publish or reproduce the published form of this work, or allow others to do so, for U.S. Government purposes.

